



Steven M. Clouse Water Recycling Center Perimeter Fence  
Solicitation Number: B-19-017-AT  
Job No.: 19-0132

**ADDENDUM 2**  
September 9, 2019

To Bidder of Record:

This addendum, applicable to work referenced above, is an amendment to the bid proposal, plans and specifications and as such will be a part of and included in the Contract Documents. Acknowledge receipt of this addendum by entering the Addendum number and issue date on the space provided in submitted copies of the bid proposal.

**CHANGES TO THE SPECIFICATIONS**

1. Replace the entire solicitation with the revised version included in this Addendum.

**CLARIFICATIONS**

1. The Changes to the Specifications listed above have been made to provide the signed and sealed documents and revisions made to the scope, bid proposal and plans provided. Respondents will utilize the signed and sealed version of the specifications when submitting a bid for this project, which includes use of the revised bid proposal.
2. An additional addendum will be issued to provide the revised map showing the drainage crossing.
3. Please see revised Invitation to Bidders for new key dates/times.

**END OF ADDENDUM**

Attachments: Solicitation B-19-017-AT



*Jeffrey J. Haby*  
9-9-2019

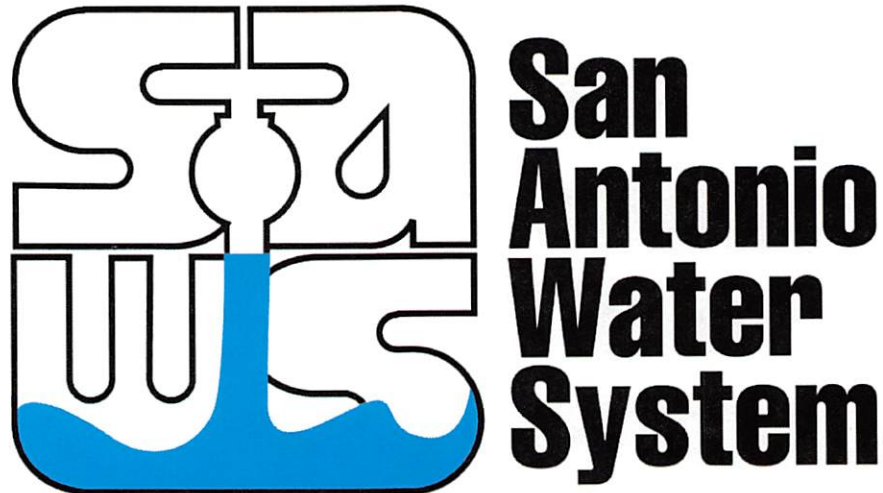

# **CONTRACT DOCUMENTS**

## **STEVEN M. CLOUSE WATER RECYCLING CENTER PERIMETER FENCE**

**SAWS Job No. 19-0132  
SAWS Solicitation No. B-19-017-AT**

**August 2019**



*Jeffrey J. Haby*  
9-9-2019

**Contract Documents**  
**Table of Contents**

| <u>BIDDING AND CONTRACT REQUIREMENTS</u>  | <u>PAGE</u> |
|---|-------------|
| Invitation to Bidders ( <i>Rev. 11/28/2018</i> ).....   | IV-1        |
| Instructions to Bidders ( <i>Rev. 7/9/2018</i> ) .....  | IB-1        |
| Workers' Compensation Insurance Coverage Requirements ( <i>Rev. 9/08/2015</i> ).....                    | WC-1        |
| Contractor's Bid Packet Checklist ( <i>Rev. 9/4/2018</i> ) .....  | BC          |
| Bid Proposal.....   | BP-1        |
| Proposal Certification ( <i>Rev. 4/14/2017</i> ).....   | PC-1        |
| Good Faith Effort Plan ( <i>Rev. 5/18/2017</i> ) .....  | GFEP-1      |
| Conflict of Interest ( <i>Rev. 11/30/2015</i> ). .....  | Form CIQ    |
| Wage Decisions .....  | WR-1        |
| General Conditions of the Contract ( <i>Rev. 6/15</i> ).....  | GC-1        |
| Contract Agreement ( <i>Rev.01/17/18</i> ) .....  | CA-1        |
| Performance and Payment Bond ( <i>Rev. 10/18/2018</i> ) .....   | PB-1        |
| Contractor Suspension Policy ( <i>Rev. 3/14</i> ) .....   | SP-1        |
| Contractor Security Procedures ( <i>Rev. 3/14</i> ).....  | SP-10       |
| Request for Taxpayer Identification Number and Certification Form ( <i>Rev. 12/2014</i> ).....          | W-9         |
| Instructions for Completing the ACORD Certificate of Liability Insurance ( <i>Rev. 1/23/2017</i> )..... | ICS         |
| Supplemental Conditions ( <i>Rev. 11/28/18</i> ).....   | SS-1        |
| Scope of Work.....  | SC-1        |
| (Separate Documents)  |             |
| CITY OF SAN ANTONIO (COSA) STANDARD SPECIFICATIONS FOR PUBLIC WORKS CONSTRUCTION (Latest Edition)       |             |
| SAWS SPECIFICATIONS FOR WATER & SANITARY SEWER CONSTRUCTION (February 2017)                             |             |

## INVITATION TO BIDDERS

Solicitation No. B-19-017-AT

Sealed bids are requested by the San Antonio Water System for the construction of approximately 4,990 linear feet chain link fence with 3-strand barbed wire, mow strip, drainage crossings and gates at Steven M. Clouse Water Recycling Center located at 3495 Valley Road, San Antonio, TX 78221 for the Steven M. Clouse Water Recycling Center Perimeter Fence Project, SAWS Job No. 19-0132.

To view additional project information, as well as obtain the plans and specifications for this project, visit our website located at [www.saws.org](http://www.saws.org) and click on the Business Center. Then select Bidder, Consultant, and Vendor Registration, which is located on the left-hand side of the screen. Select the Register Now button and proceed with registration.

For difficulties downloading plans and specifications, contact the Contracting Department at 210-233-3341.

A **mandatory** pre-bid meeting will be held at **9:00 AM (CT) on Thursday, September 5, 2019** at the San Antonio Water System's Steven M. Clouse Water Recycling Center located at 3495 Valley Road, San Antonio, Texas 78221. Please be advised that under no circumstances shall any late or non-attendee(s) to the Mandatory Pre-Bid Meeting be allowed to submit a bid for the project.

For questions regarding this solicitation, technical questions or additional information, please contact Andrea C. Tena, Contract Administrator, in writing via email to: [andrea.tena@saws.org](mailto:andrea.tena@saws.org) until **4:00 PM (CT) on September 10, 2019**. Answers to the questions will be posted to the web site by **12:00 PM (CT) on September 11, 2019** as a separate document or included as part of an addendum. Please be advised that Bidders are prohibited from communicating with any other SAWS staff, the Consultant, the Developer, or City of San Antonio officials regarding this IFB up until the contract is awarded as outlined in the Instructions to Bidders.

**Sealed bids will be received** by Counter Services in the Customer Service office across from the Guard Station, 2800 U.S. Hwy 281 North, Customer Center Building, San Antonio, Texas 78212, **until 1:00 PM (CT), September 17, 2019**. Bids will then be publicly opened and read aloud by Contract Administration in CR-C169, Customer Center Building, 2800 U.S. Hwy 281 North, San Antonio, Texas. Each bid must be accompanied by a cashier's check, certified check, or bid bond in an amount not less than five percent of the total bid price.

## INSTRUCTIONS TO BIDDERS

The San Antonio Water System (SAWS) Board of Trustees or its designee have determined that the Competitive Bidding method of procurement will be utilized for this project. The construction contract will be awarded to the lowest responsible bidder. This procurement shall conform to Section 2269 of the Texas Government Code.

1. Bids will be submitted in accordance with the following:
  - a. **Personal/hand delivered** sealed bids will be received by **Counter Services** in the Customer Service office across from the Guard Station, **San Antonio Water System, 2800 U.S. Hwy 281 North, Customer Center Building, Suite 141, San Antonio, Texas 78212**, until the time specified in the Invitation to Bidders.
  - b. If the submittal of a sealed bid is by **any means other than personal/hand delivery**, then it is the bidder's sole responsibility to ensure the bid is delivered to San Antonio Water System, 2800 U.S. Hwy 281 North, Customer Center Building - **Contract Administration, Suite 171**, San Antonio, Texas 78212, no later than the exact time specified in the Invitation to Bidders.
  - c. All bids errantly submitted or delivered to a location other than the exact location stated above will be returned unopened.
  - d. All bids received after the exact time set for the bid opening in the Invitation to Bidders will be returned unopened.
  - e. The San Antonio Water System Contracting Office may, at its sole discretion, without waiver of rights or authority, in equity or at law, return unopened, any bid not meeting the exact requirements as stated above.
  
2. Bids will be opened in accordance with the following:
  - a. Bids will be opened in a public setting and read aloud by a Contract Administration representative.
  - b. The lowest bid received at the time of the bid opening shall be designated as the "apparent low bid," whether announced in that manner or not, and shall not represent an acceptance of an offer.
  - c. All bid results are unofficially, tentative and subject to verification on the day of the bid opening.
  - d. No bid may be withdrawn after the scheduled bid opening time without the written consent of a Contract Administration representative.
  - e. The "official" bid results will be tallied on a "bid tabulation sheet" and may, within 10 business days of the bid opening, be posted on the San Antonio Water System's web site.
  
3. All bids must be accompanied by Certified or Cashier's Check or an approved Bid Bond in the amount of not less than five percent (5%) of the total bid, payable without recourse to the San Antonio Water System. Surety shall provide a copy of the Power of Attorney authorizing the Executing Agent the authority to execute the bid bond documents and bind the Surety to the bid bond conditions. The bid bond shall have a corporate Surety that is licensed to conduct business in Texas and authorized to underwrite bonds in the amount of the bid bond. ***Submission of an Individual Surety is not acceptable for purposes of bonding a bid bond.*** Bid Bonds, Certified or Cashier's checks will be retained for the first, second, and third lowest bidders until the contract is executed.

4. Bids must be submitted on the original bid form attached herein and shall be sealed in an envelope plainly marked on the outside with job number, the date and time of the bid opening, and the name of project bid on.
5. Bids will be prepared in accordance with the following:
  - (a) The Bidder shall thoroughly examine the drawings, specifications, schedule, instructions and all other documents.
  - (b) Bidder shall make all investigations necessary to be informed thoroughly regarding plant and facilities for delivery of material and equipment as required by the bid conditions. No plea of ignorance by the Bidder of conditions that exist, or that may hereafter exist as a result of failure or omission on the part of the Bidder to make the necessary examinations and investigations to fulfill in every detail the requirements of the contract documents, will be accepted as the basis for varying the requirements of the San Antonio Water System or the compensation to the Contractor. Bidders are required, prior to submitting the Bid Proposal, to review the plans and read the specifications, special provisions and or special conditions, any addendums issued, proposal, contract and bond forms carefully; to visit the site of the work; to examine carefully local conditions; to inform themselves by their independent research, tests and investigations of the difficulties to be encountered and judge for themselves the accessibility of the work and all attending circumstances affecting the cost of doing the work or time required for its completion; and to obtain all information required to make an intelligent proposal. Bidders shall rely exclusively upon their own estimates, investigations, tests and other data which are necessary for full and complete information upon which the proposal may be based. Any bidder, by submitting their Bid Proposal, represents and warrants: that they have prepared their bid in accordance with the specifications, with full knowledge and understanding of the terms and provisions thereof; that they have reviewed, studied and examined the bid prior to the signing and submission of same; and that they were cognizant of the terms of their proposal, verified their calculations and found them to be correct and agrees to be bound thereby; and that they have visited the site of work, have fully familiarized themselves with the local and on-site conditions under which the work is to be performed and have correlated their observation with the requirements of the contract documents. In addition, the Bidder represents that they have satisfied themselves as to subsurface conditions at the site of the work. Information, data and representations contained in the contract documents pertaining to the conditions at the site, including but not limited to subsurface conditions, are for information only and are not warranted or represented in any manner to accurately show the conditions at the site of the work. All risks of differing conditions at the site, including but not limited to subsurface conditions shall be borne solely by the Bidder.
  - (c) The Bidder shall furnish all information required by the bid form. The Bidder shall print or type their name and manually sign the Bid Proposal in the required area of the document.
  - (d) The Bidder is required to submit a Good Faith Effort Plan form and all SMWVB Certification Certificates for the bidder or their subcontractors as part of the bid package. Bidder and/or their agents may contact the SMWVB Program Manager, Marisol V. Robles, at 210-233-3420 for assistance or clarification with issues specifically related to the Small, Minority, Woman and Veteran-owned Business (SMWVB) Program policy and/or completion of the Good Faith Effort Plan form.
  - (e) The Bidder is required to submit a completed Conflict of Interest Questionnaire (CIQ Form). Effective

January 1, 2006, Chapter 176 of the Texas Local Government Code requires that persons, or their agents, who seek to contract for the sale or purchase of property, goods, or services with SAWS shall file a completed Conflict of Interest Questionnaire (CIQ) with SAWS. The CIQ Form will be submitted as part of the bid. This form is available from the Texas Ethics Commission at [www.ethics.state.tx.us](http://www.ethics.state.tx.us). Please consult your own legal advisor if you have questions regarding the statute or form. To report suspected ethics violations impacting The San Antonio Water System, please call 1-800-687-1918.

- (f) The Bidder is required to submit as part of the bid a letter from the insurance provider stating provider's commitment to insure the Contractor for the types of coverage's or an Insurance Certificate to be in conformance with the types of coverage's noted in General Conditions Section 5.7 – Contractor's Insurance Requirements, if awarded the contract.
  - (g) Pursuant to Section 151.311 of the Texas Tax Code, as amended, in order for the San Antonio Water System to continue to benefit from its status as a State Sales and Use Tax Exempt Organization, construction contracts must be awarded on a "separated contract" basis. A "separated contract" is one that distinguishes the value of the tangible personal property (materials such as pipe, bricks, lumber, concrete, paint, etc.) to be incorporated into the project from the total contract price. Under the "separated contract" format, the contractor in effect becomes a "seller" to the San Antonio Water System of materials that are to be physically incorporated into the project realty. As a "seller", the contractor will issue a "Texas Certificate of Resale" to the supplier in lieu of paying the sales tax on materials at the time of purchase. The contractor will also issue a "Certificate of Exemption" to the supplier demonstrating that the personal property is being purchased for resale and that the resale is to a department of the City of San Antonio, Texas, which is a sales tax exempt entity. Contractors should be careful to consult the most recent guidelines of the State Comptroller of Public Accounts regarding the sales tax status of supplies and equipment that are used and consumed during project work but that are not physically incorporated into the project realty. Contractors that have questions about this law are asked to inquire with the State Comptroller of Public Accounts, at (512) 463-4600. Bidders will not include any federal taxes in bid prices since the San Antonio Water System is exempt from payment of such taxes. "Texas Certificates of Exemption", "Texas Certificates of Resale" and "Texas Sales Tax Permits" are forms available to the contractor through the regional offices of the State Comptroller of Public Accounts.
6. Bidders should adhere to the following restrictions in communication:
- (a) Bidders or their representatives are prohibited from communicating with any City of San Antonio officials regarding this solicitation from the time it is released until it has been acted upon by the Board of Trustees, which includes:
    - City Council members (as defined by the City of San Antonio Ethics Code),
    - City Council member's staff, and
    - San Antonio Water System (SAWS) Board of Trustees.
  - (b) Bidders or their representatives are prohibited from communicating with SAWS employees regarding this IFB, except as provided under "Technical Questions" to the point of contact identified within the Invitation to Bidders, from the time the solicitation is released until the contract is awarded.
  - (c) Bidders or their representatives are prohibited from communicating with the Consultant, Developer, or any contract staff who were or are involved in the development of this IFB, regarding this IFB, from the time the solicitation is released until the contract is awarded.

- (d) Communication includes “thank you” letters, phone calls, emails, and any contact that results in direct or indirect discussion of the IFB and/or bid submitted.
  - (e) If it is determined that a Bidder violates this provision, SAWS may disqualify the bid from consideration.
7. Any catalogue or manufacturer's reference used in describing an item is merely descriptive, and not restrictive unless otherwise noted, and is used only to indicate type and quality of material. When items proposed differ in any way from those specified, Bidders are required to state exactly what they intend to furnish. Otherwise, they shall be required to furnish the items as specified.
8. The work shall be done and completed in accordance with the following Contract Documents as furnished by the San Antonio Water System:
- a. The Invitation to Bidders
  - b. The Instructions to Bidders
  - c. The Bid Proposal
  - d. The Payment Bond
  - e. The Performance Bond
  - f. The General Conditions of the Contract
  - g. The Supplemental Conditions of the Contract
  - h. The Special Conditions of the Contract
  - i. The Construction Specifications
  - j. The Standard Drawings
  - k. Addenda
  - l. Change Orders
  - m. Good Faith Effort Plan
  - n. Conflict of Interest Questionnaire
9. The successful Bidder will be required to execute the standard San Antonio Water System Contract Agreement, Performance and Payment Bonds as outlined in the General Conditions. These forms will be prepared and furnished by the San Antonio Water System. As part of the contract requirements:
- (a) Surety shall provide a copy of the Power of Attorney authorizing the Executing Agent the authority to execute the bond documents and bind the Surety to the bond conditions. These bonds shall have a corporate Surety that is licensed to conduct business in Texas and authorized to underwrite bonds in the amount of the project. Contractor agrees that all Performance and Payment Bonds required shall be submitted in accordance with General Conditions, Sections 3.4 & 3.5. If the contract amount does not exceed \$25,000.00, then the Performance and Payment Bonds will not be required.
  - (b) Contractor agrees that it does not boycott Israel and will not do so during the term of this Contract. This provision is in compliance with §2270.001 of the Texas Government Code. SAWS agrees to comply with the United States and Texas Constitutions in consideration of whether to enforce this provision.
10. Where there is an error in the extension, the San Antonio Water System Contracting Office will extend the written unit price and make any corrections necessary. Any error will be corrected, and the correct amount will be the basis for determining the bid position.
11. Bidders are advised that estimated quantities of anticipated requirements during the contract period are



not calculated with certainty. It is the policy of the Board, however, as a matter of prudent buying and contracting, to establish in advance of actual purchase or performance of the work, the price of the work which is anticipated, and the price on certain items calculated on the maximum number of a particular item which it might need during a contract period. Bidders are advised that during such period, the Board may determine not to purchase any of the items or may delete any or all of the work listed in a bid or invitation. Under such a contract, the Board's only commitment is to purchase the items from or proceed with the work by the successful Bidder at the price bid if the Board should, in fact, decide to purchase such items during the contract period or proceed with such work as proposed. On all bids, the Board reserves the right to reject a bid, which in the Board's judgment is "unbalanced." An "unbalanced bid" is defined as one in which a particular item or a class of items is bid at a figure sufficiently less than or higher than either general market price or Bidder's cost, so as to make the Bidder low on the overall bid but high on a significant number of other items. The Board reserves the right to exercise its judgment and reject such a bid as unqualified. If the Board nevertheless accepts such an unbalanced bid and the contract is awarded, the Board reserves the right to delete any or all of such items from the purchases to be made or work to be done.

12. SAWS will provide all necessary easements for the project.
13. No owner, stockholder, partner, officer, or employee of the Bidder, or any person who has a financial interest in this contract in any way, whether direct or indirect, shall be an officer or employee of the San Antonio Water System or the City of San Antonio at the time of bidding on this contract, or during the life of this contract. Any violations of this provision will render the bid or contract void.
14. The Contractor will establish a San Antonio address and telephone number and file that information with the Contracting Officer prior to starting work. If the contractor does not have a local office then they must submit the address and telephone number of the field office established for this project. The Contractor's address and telephone number will be maintained until the work is completed and accepted by the owner.
15. In case of ambiguity, duplication or obscurity in the bids, the San Antonio Water System Contracting Office reserves the right to construe and apply the meaning thereof. The San Antonio Water System Contracting Office reserves the right to reject any and all bids and to waive formalities.
16. The San Antonio Water System Contracting Office reserves the right, subject to the Contractor's approval, to extend any annual contract for an additional period of not more than one year, subject to the same terms and conditions as enumerated in the invitation and instruction to Bidders and at a price or prices not to exceed the prices quoted.
17. It is anticipated that the contract will be awarded within **60** days after bid opening to the **Responsible Bidder** whose bid, conforming to the invitation for bids, is most advantageous to the San Antonio Water System. Bidders are advised that the awarding of contracts on a bid basis is a requirement of state law and city charter. The purposes of such requirements are: (1) to prevent the historic abuses of negotiated purchases; (2) to enable the Board to use its purchasing power to buy at the lowest possible prices for the benefit of the system and the public; and (3) to enable the Board to award the contract to other than the low Bidder when, in the Board's judgment, the low Bidder is not qualified. Bidders are advised that it is not the intention of the Board, necessarily, to award contracts on the basis of differences in the bids other than differences in basic "price of the item." The Board reserves the right to take whichever action as may, in the judgment of the Board, to be its best interest as follows:

- (1) Reject all bids;
- (2) Award the bids by the drawing of lots; or
- (3) Award the bids on the basis of differences other than price.

Bidders are advised that the awarding of bids is a matter solely within the jurisdiction of the Board of Trustees. The San Antonio Water System reserves the right to accept any items or groups of items in this bid. Execution of written acceptance of a bid by the San Antonio Water System shall constitute an award.

18. The San Antonio Water System Contracting Office may reject the apparent low Bidder when: (a) the Bidder misstates or conceals any material fact in the bid, or if (b) the Bidder does not conform with the law or the bid, or if (c) the bid is conditional, or if (d) the bid is unbalanced, or when (e) the lowest Bidder is not, in the Board's judgment, qualified, or when (f) the lowest bid is not, in the Board's judgment, the lowest and best bid, or if (g) the Bidder fails to acknowledge in the final bid price of the bid any and all addendums issued on the bid proposal prior to bid opening , or if (h) the Bidder fails to follow the restriction from communication outlined in the Instructions to Bidders.

It will be the full responsibility of each Bidder to visit the SAWS web site to verify the existence of and acknowledge on the bid proposal, any and all addendums issued by the San Antonio Water System. The San Antonio Water System Contracting Office reserves the right to reject any and all bids, to accept any bids, or parts thereof, considered by the San Antonio Water System to be to its best interest, and to waive formalities or irregularities.

19. The Bidder in preparing their bid, shall take cognizance of the difficulty of distinguishing between boulders and ledge rock, the difficulty of accurately classifying all material encountered in making the subsurface investigations, the possible erosion of stream channels and banks after survey data has been obtained, and the unreliability of water elevations other than those for the date recorded. Claims for additional compensation due to variations between conditions actually encountered in a construction and as indicated in the plans will not be allowed.

20. All contracts in excess of \$10,000 with contractors or suppliers having 15 or more employees will include the clauses listed below:

- (a) The Contractor will not discriminate against any employee or applicant for employment because of race, color, religion, sex, pregnancy, sexual orientation, national origin, political belief or affiliation, age, disability or genetic information. The Contractor will assure that employees or applicants for employment are treated in a fair and equitable manner in such actions which shall include but not be limited to the following: Employment, upgrading, demotion or transfer, recruitment or recruitment advertising, layoff or termination, rates of pay or other forms of compensation, and selection for training including apprenticeship. The Contractor will post in conspicuous places for the benefit of the employee and applicants for employment notices setting forth the provisions of this nondiscrimination clause.
- (b) Upon request, the Contractor will furnish to the San Antonio Water System all information and reports and will permit access to the books, records, and accounts for the purposes of an investigation to ascertain compliance with rules and regulations set forth by this organization.
- (c) If a Contractor is found not to be in compliance with the nondiscrimination clause of this contract,

the contract may be canceled, terminated, or suspended in all or in part and the Contractor may be debarred from further contracts with the San Antonio Water System.

- (d) All Bidders or prospective Contractors or Subcontractors will be required to submit a statement in writing signed by an authorized official or agent in behalf of the company to the effect that the signer's practices and policies do not discriminate on the grounds of race, color, religion, sex, or national origin.

The Contractor shall comply with all provisions of Executive Order 11246, Equal Employment Opportunity, dated 24 September 1965 or as amended and with Section 3 of the Housing and Urban Development Act of 1968 covering opportunities for business and lower financed HUD assisted projects.

#### **Statement on President's Executive Orders**

Has your firm previously performed work subject to the President's Executive Orders Numbers 11246 and 11375 or any preceding similar executive orders (Numbers 10925 and 11114)?

Yes  No

Contractors/Consultants/Vendors on work paid by federal funds will be required to comply with the president's executive order no. 11246, "Equal Employment Opportunity," as amended by executive order no. 11375, "amending executive order 11246 relating to equal employment opportunity," and as supplemented by regulations at 41 CFR part 60, Office of Federal Contract Compliance Programs, Equal Employment Opportunity, Department Of Labor.

21. Approval of Plans and/or Specifications by an employee of SAWS shall not constitute an assumption of liability by the San Antonio Water System or such employee for any inaccuracy of computation or deficiency of design therein.
22. Bidder shall not offer, confer, or agree to confer any benefit or gift to any San Antonio Water System Employee, Officer, or Trustee of the Board of the San Antonio Water System and Water System employees are prohibited from soliciting, accepting or agreeing to accept any gifts from outside sources; please see Section M. – Gifts or Benefits of the Water System's Code of Ethical Standards. Section M of the Water System's Code of Ethical Standards regarding Gifts or Benefits is available on the SAWS Business Center website.
23. Contractor shall comply with the "WORKERS COMPENSATION INSURANCE COVERAGE REQUIREMENTS" as noted on Section 5.7 CONTRACTOR'S INSURANCE REQUIREMENTS of the General Conditions for further clarification.
24. To assist the San Antonio Water System Contracting Office in performing the bidder evaluation and subsequent recommendation of award, the apparent low bidder will submit the following items within one (1) day of the bid opening. Failure to provide the required information within the specific time, may result in determining a non-responsive bidder:
  - (a) An information packet on company showing experience, organization and equipment.
  - (b) A statement regarding ability to complete the project within the schedule taking into account existing commitments.
  - (c) Record of performance on three (3) similar projects completed within the last 5 years including name of project, amount of project, project duration, name, address, and telephone number of contact person for each project.

- (d) A completed and signed W-9 Request for Taxpayer Identification Number and Certification form.
- (e) **For projects with a construction estimate of \$10,000,000 or greater:**  
A complete financial statement for your organization that was prepared within the past 12 months, by an independent Certified Public Accountant, and a point of contact for your banking institution.

25. In 2015, and made effective as of January 1, 2016, the Texas Legislature adopted House Bill 1295, which added section 2252.908 of the Government Code. The law states that a governmental entity or state agency may not enter into certain contracts with a business entity unless the business entity submits a disclosure of interested parties (Form 1295) to the governmental entity or state agency at the time the business entity submits the signed contract to the governmental entity or state agency. The Texas Ethics Commission has adopted rules requiring the business entity to file Form 1295 electronically with the Commission. The online filing application is available on the Texas Ethics Commission (TEC)'s website. A copy of the completed form, which will include a certification of filing that with a unique certification number, will be required with the signed contract. For additional information, Bidders may go to the Texas Ethics Commission website at the following link:

[https://ethics.state.tx.us/whatsnew/elf\\_info\\_form1295.htm](https://ethics.state.tx.us/whatsnew/elf_info_form1295.htm)

## Workers' Compensation Insurance Coverage

### A. Definitions:

Certificate of coverage ("certificate")- A copy of a certificate of insurance, a certificate of authority to self-insure issued by the division [or a coverage agreement (DWC Form-81, DWC Form-82, DWC Form-83, or DWC Form-84,) showing statutory workers' compensation insurance coverage for the person's or entity's employees providing services on a project, for the duration of the project.

Duration of the project - includes the time from the beginning of the work on the project until the contractor's/person's work on the project has been completed and accepted by the governmental entity.

Persons providing services on the project ("subcontractor" in §406.096) - includes all persons or entities performing all or part of the services the contractor has undertaken to perform on the project, regardless of whether that person contracted directly with the contractor and regardless of whether that person has employees. This includes, without limitation, independent contractors, subcontractors, leasing companies, motor carriers, owner-operators, employees of any such entity, or employees of any entity which furnishes persons to provide services on the project. "Services" include, without limitation, providing, hauling, or delivering equipment or materials, or providing labor, transportation, or other service related to a project. "Services" does not include activities unrelated to the project, such as food/beverage vendors, office supply deliveries, and delivery of portable toilets.

- B. The contractor shall provide coverage, based on proper reporting of classification codes and payroll amounts and filing of any coverage agreements, which meets the statutory requirements of Texas Labor Code, Section 401.011(44) for all employees of the contractor providing services on the project, for the duration of the project.
- C. The Contractor must provide a certificate of coverage to the governmental entity prior to being awarded the contract.
- D. If the coverage period shown on the contractor's current certificate of coverage ends during the duration of the project, the contractor must, prior to the end of the coverage period, file a new certificate of coverage with the governmental entity showing that coverage has been extended.
- E. The contractor shall obtain from each person providing services on a project, and provide to the governmental entity:

- (1) a certificate of coverage, prior to that person beginning work on the project, so the governmental entity will have on file certificates of coverage showing coverage for all persons providing services on the project; and
  - (2) no later than seven days after receipt by the contractor, a new certificate of coverage showing extension of coverage, if the coverage period shown on the current certificate of coverage ends during the duration of the project.
- F. The contractor shall retain all required certificates of coverage for the duration of the project and for one year thereafter.
- G. The contractor shall notify the governmental entity in writing by certified mail or personal delivery, within 10 days after the contractor knew or should have known, of any change that materially affects the provision of coverage of any person providing services on the project.
- H. The contractor shall post on each project site a notice, in the text, form and manner prescribed by the Division of Workers' Compensation, informing all persons providing services on the project that they are required to be covered, and stating how a person may verify coverage and report lack of coverage.
- I. The contractor shall contractually require each person with whom it contracts to provide services on a project, to:
- (1) provide coverage, based on proper reporting of classification codes and payroll amounts and filing of any coverage agreements, which meets the statutory requirements of Texas Labor Code, Section 401.011(44) for all of its employees providing services on the project, for the duration of the project;
  - (2) provide to the contractor, prior to that person beginning work on the project, a certificate of coverage showing that coverage is being provided for all employees of the person providing services on the project, for the duration of the project;
  - (3) provide the contractor, prior to the end of the coverage period, a new certificate of coverage showing extension of coverage, if the coverage period shown on the current certificate of coverage ends during the duration of the project;
  - (4) obtain from each other person with whom it contracts, and provide to the contractor:

- (a) a certificate of coverage, prior to the other person beginning work on the project; and
    - (b) a new certificate of coverage showing extension of coverage, prior to the end of the coverage period, if the coverage period shown on the current certificate of coverage ends during the duration of the project;
  - (5) retain all required certificates of coverage on file for the duration of the project and for one year thereafter;
  - (6) notify the governmental entity in writing by certified mail or personal delivery, within 10 days after the person knew or should have known, of any change that materially affects the provision of coverage of any person providing services on the project; and
  - (7) contractually require each person with whom it contracts, to perform as required by paragraphs (1) - (7), with the certificates of coverage to be provided to the person for whom they are providing services.
- J. By signing this contract or providing or causing to be provided a certificate of coverage, the contractor is representing to the governmental entity that all employees of the contractor who will provide services on the project will be covered by workers' compensation coverage for the duration of the project, that the coverage will be based on proper reporting of classification codes and payroll amounts, and that all coverage agreements will be filed with the appropriate insurance carrier or, in the case of a self-insured, with the division. Providing false or misleading information may subject the contractor to administrative penalties, criminal penalties, civil penalties, or other civil actions.
- K. The contractor's failure to comply with any of these provisions is a breach of contract by the contractor which entitles the governmental entity to declare the contract void if the contractor does not remedy the breach within ten days after receipt of notice of breach from the governmental entity.

**BID PACKET CHECKLIST**  
**Clouse WRC Perimeter Fence Project**  
**SAWS Job No. 19-0132**  
**SAWS Solicitation No. B-19-017-AT**

**This checklist is a required document that must be utilized and submitted with the Bid Packet. The Bid Packet should include the following items:**

- Signed Bid Proposal and Acknowledgement of All Addendums
- Signed Proposal Certification
- Bid Bond/Cashier's Check
- Statement on President's Executive Orders – Page IB – 7
- Completed Good Faith Effort Plan
- Conflict of Interest Questionnaire - Form CIQ (*Rev. 11/30/2015*)
- Proof of Insurability (Letter from Insurer or Sample Certificate of Insurance)
- Statement regarding ability to complete the project
- Company information packet showing experience, organization and equipment.
- Statement regarding ability to complete the project within the schedule taking into account existing commitments.
- Completed and signed W-9 Request for Taxpayer Identification Number and Certification form.
- Record of performance on three (3) similar projects completed within the last 5 years including name of project, amount of project, project duration, name, address, and telephone number of contact person for each project.
- Baseline schedule in Microsoft Project Format



BID PROPOSAL

PROPOSAL OF \_\_\_\_\_, a corporation  
 a partnership consisting of \_\_\_\_\_  
 an individual doing business as \_\_\_\_\_

THE SAN ANTONIO WATER SYSTEM:

Pursuant to Instructions and Invitations to Bidders, the undersigned proposes to furnish all labor and materials as specified and perform the work required for the project as specified, in accordance with the Plans and Specifications for the following prices to wit:

| Item | Description                                     | UM          | Qty   | Unit Price | Total Price |
|------|---|-------------|-------|------------|-------------|
| 1    | Security Fence                                  | Lineal feet | 4,990 |            |             |
| 2    | 16' double gate                                 | Each        | 4     |            |             |
| 3    | 12' gate  | Each        | 1     |            |             |
| 4    | 6' Personal gate                                | Each        | 2     |            |             |
| 5    | 5' Personal gate                                | Each        | 1     |            |             |
| 6    | 22' channel crossing, welded, with fence fabric | Each        | 1     |            |             |
| 7    | 51'-6" channel crossing, welded, with gate      | Each        | 1     |            |             |
| 8    | Grass channel crossing, with fence              | Each        | 1     |            |             |

**TOTAL BID AMOUNT** \$ \_\_\_\_\_

\_\_\_\_\_  
 BIDDER'S SIGNATURE & TITLE  
 \_\_\_\_\_  
 FIRM'S NAME (TYPE OR PRINT)  
 \_\_\_\_\_  
 FIRM'S ADDRESS  
 \_\_\_\_\_  
 FIRM'S PHONE NO. /FAX NO.  
 \_\_\_\_\_  
 FIRM'S EMAIL ADDRESS

The Contractor herein acknowledges receipt of the following:  
 Addendum Nos. \_\_\_\_\_

OWNER RESERVES THE RIGHT TO ACCEPT THE OVERALL MOST RESPONSIBLE BID.

The bidder offers to construct the Project in accordance with the Contract Documents for the contract price, and to complete the Project within **60** calendar days after the start date, as set forth in the Authorization to Proceed. **The bidder understands and accepts the provisions of the contract Documents relating to liquidated damages of the project if not completed on time.**  
 Complete the additional requirements of the Bid Proposal which are included on the following pages.

# PROPOSAL CERTIFICATION

Accompanying this proposal is a Bid Bond or Certified or Cashier's Check payable to the Order of the San Antonio Water System for \_\_\_\_\_ dollars (\$\_\_\_\_\_), which amount represents five percent (5%) of the total bid price. Said bond or check is to be returned to the bidder unless the proposal is accepted and the bidder fails to execute and file a contract within **10** calendar days after the award of the Contract, in which case the check shall become the property of said San Antonio Water System, and shall be considered as payment for damages due to delay and other inconveniences suffered by said San Antonio Water System due to the failure of the bidder to execute the contract. The San Antonio Water System reserves the right to reject any and all bids.

It is anticipated that the Owner will act on this proposal within **60** calendar days after the bid opening. Upon acceptance and award of the contract to the undersigned by the Owner, the undersigned shall execute standard San Antonio Water System Contract Documents and make Performance and Payment Bonds for the full amount of the contract within **10** calendar days after the award of the Contract to secure proper compliance with the terms and provisions of the contract, to insure and guarantee the work until final completion and acceptance, and the guarantee period stipulated, and to guarantee payment of all lawful claims for labor performed and materials furnished in the fulfillment of the contract.

It is anticipated that the Owner will provide written Authorization to Proceed within **30** days after the award of the contract.

The work called for in this Contract shall commence on the date indicated in the SAWS written Authorization to Proceed Under no circumstances shall the work commence prior to the date provided for in the SAWS issued, written Authorization to Proceed. Work shall be completed in full within 60 consecutive calendar days.

The undersigned further acknowledges compliance with "Wage and Labor Standard Provisions" of this contract and the use of the Blue Book rental rates for establishment of equipment rental rates whether owned or leased during the course of this Contract.

In completing the work contained in this proposal the undersigned certifies that bidder's practices and policies do not discriminate on the grounds of race, color, religion, sex or national origin and that the bidder will affirmatively cooperate in the implementation of these policies and practices.

Signed: \_\_\_\_\_  
Company Representative

\_\_\_\_\_  
Company Name

\_\_\_\_\_  
Address

Please return bidder's check to: \_\_\_\_\_  
Company Name

\_\_\_\_\_  
Address



**Good Faith Effort Plan for Construction SUBCONTRACTS for:**

NAME OF PROJECT: B-19-017-AT, Clouse WRC Perimeter Fence Project

**SECTION A - PRIME CONTRACTOR INFORMATION**

Legal Name of Firm, including "doing business as" if applicable: \_\_\_\_\_

Address of Office to Perform Project Work: \_\_\_\_\_

City: \_\_\_\_\_ State: \_\_\_\_\_ Zip Code: \_\_\_\_\_

Telephone: \_\_\_\_\_ Fax: \_\_\_\_\_

Contact Person: \_\_\_\_\_

Email Address: \_\_\_\_\_

Is your firm  
Certified as an SMWVB? Yes: \_\_\_\_\_ No: \_\_\_\_\_

If "Yes", was your firm certified by the South Central Texas Regional Certification Agency (SCTRCA) or the Texas Comptroller's Office (HUB)? Only SCTRCA or HUB certifications granted to "local" firms are recognized. Please see the Good Faith Effort Plan Definition for "Local":

Yes: \_\_\_\_\_ No: \_\_\_\_\_

Type/s of Certification: SBE: \_\_\_\_\_ MBE: \_\_\_\_\_ VBE: \_\_\_\_\_ WBE: \_\_\_\_\_

Prime Contractor's Percentage of Participation: (Ex: 100% is the total value of the contract.) \_\_\_\_\_%

Describe your firm's participation to be performed on this Project: \_\_\_\_\_  
 \_\_\_\_\_  
 \_\_\_\_\_

1. List ALL SUBCONTRACTORS/SUPPLIERS that will be utilized on this project/contract. (SMWVB AND Non-SMWVB)

|   | Legal Name of Subcontractor/Supplier (including "doing business as", if applicable). | Address of Office Location to Perform Project Work or Provide Supplies. (Only Local firms will be counted for SMWVB credit): | Scope of Work/Supplies to be Performed/Provided by Firm: | Estimated Contract (dollar) Amount on this Project: | Certification Type & Agency. (Only SCTRCA or HUB certifications are recognized): |
|---|--|--|--|---|--|
| 1 |  |  |  |   |  |
| 2 |  |  |  |   |  |
| 3 |  |  |  |   |  |
| 4 |  |  |  |   |  |
| 5 |  |  |  |   |  |

**SECTION B. – SMWB COMMITMENTS**

The SMWVB goal on this project is 20%

1. The undersigned proposer has satisfied the requirements of the BID specification in the following manner (please check the appropriate space):

\_\_\_\_\_ The proposer is committed to a minimum of 20 % SMWVB utilization on this contract.

\_\_\_\_\_ The proposer, (if unable to meet the SMWVB goal of 20%), is committed to a minimum of \_\_\_\_\_% SMWVB utilization on this contract. (If unable to meet the goal, please fill out Section C and submit documentation demonstrating good faith efforts).

2. Name and phone number of person appointed to coordinate and administer the SMWVB requirements on this project.

Name:

\_\_\_\_\_

Title:

\_\_\_\_\_

Phone Number:

\_\_\_\_\_

Email Address:

\_\_\_\_\_

IF THE SMWB GOAL WAS MET, PROCEED TO AFFIRMATION AND SIGN THE GFEP. IF GOAL WAS NOT MET, PROCEED TO SECTION C.

**SECTION C – GOOD FAITH EFFORTS (Fill out only if the SMWVB goal was not achieved).**

1. On a separate sheet of paper, list and attach to this Good Faith Effort Plan written, posted, or published notification to all firms you contacted with subcontracting/supply opportunities for this project that will not be utilized for the contract by choice of the proposer, subcontractor, or supplier. Notices to firms contacted by the proposer for specific scopes of work identified for subcontracting/supply opportunities must be provided to subcontractor/supplier not less than five (5) business days prior to bid/proposal due date. This information is required for all firms that were contacted of subcontracting/supply opportunities.

Copies of said notices must be provided to the SMWVB Program Manager at the time the response is due. Such notices shall include information on the plans, specifications, and scope of work.

2. Did you attend the pre-bid conference scheduled for this project? \_\_\_\_\_ Yes \_\_\_\_\_ No

3. List all SMWVB listings or directories, contractor associations, and/or any other associations utilized to solicit SMWB Subcontractors/suppliers:

\_\_\_\_\_

4. Discuss efforts made to identify elements of the work to be performed by SMWVBs in order to increase the likelihood of achieving the goal:

\_\_\_\_\_

\_\_\_\_\_

5. Indicate advertisement mediums used for soliciting bids from SMWVBs. (Please attach a copy of the advertisement(s):

\_\_\_\_\_

\_\_\_\_\_

**AFFIRMATION**

I hereby affirm that the above information is true and complete to the best of my knowledge. I further understand and agree that, this document shall be attached thereto and become a binding part of the contract.

**Name and Title of Authorized Official:**

Name:

\_\_\_\_\_

Title:

\_\_\_\_\_

Signature:

\_\_\_\_\_

Date:

\_\_\_\_\_

**NOTE:**

This Good Faith Effort Plan is reviewed by SAWS Contracting Department. For questions and/or clarifications, please contact Marisol V. Robles, SMWVB Program Manager, at 210-233-3420.

## **DEFINITIONS**

**Note:** To be eligible for participation in the SAWS Small, Minority, Woman, and Veteran-owned Business Program, a firm must be local, and must be certified as a Small Business Enterprise (SBE). This includes firms certified as Minority and/or Woman-owned Business Enterprises (MBEs and WBEs). SAWS tracks Veteran-owned Business Enterprises (VBEs) for statistical purposes, but does not award points for VBE participation.

**Local:** A business located in the San Antonio Metropolitan Statistical Area (SAMSA) , which includes the counties of Atascosa, Bandera, Bexar, Comal, Frio, Guadalupe, Kendall, Kerr, McMullen, Medina, Uvalde and Wilson. A business's presence in the SAMSA that consists solely of a P.O. box, a mail drop, or a telephone message center does not count as being local.

**Prime Consultant/Contractor:** Any person, firm partnership, corporation, association or joint venture which has been awarded a San Antonio Water System contract.

**Subconsultants/contractor:** Any named person, firm partnership, corporation, association or joint venture identified as providing work, labor, services, supplies, equipment, materials or any combination of the foregoing under contract with a prime consultant/contractor on a San Antonio Water System contract.

**Small, Minority and Woman Business (SMWB):** All business structures Certified by the Texas Comptroller's Office (HUB), or the South Central Texas Regional Certification Agency that are 51% owned, operated, and controlled by a Small Business Enterprise, a Minority Business Enterprise, or a Woman-owned Business Enterprise.

**Small Business Enterprise (SBE):** A business structure that is Certified by the Texas Comptroller's Office (HUB), or the South Central Texas Regional Certification Agency as being 51% owned, operated and controlled by someone who is legally residing in or a citizen of the United States, and the business structure meets the U.S. Small Business Administration's (SBA) size standard for a small business within the appropriate industry category.

**Minority Business Enterprise (MBE):** A business structure that is Certified by the Texas Comptroller's Office (HUB) or the South Central Texas Regional Certification Agency as being 51% owned, operated, and controlled by an ethnic minority group member(s) who is legally residing in or a citizen of the United States. For purposes of the SMWB program, the following are recognized as minority groups:

- a. **African American** – Persons having origins in any of the black racial groups of Africa.
- b. **Hispanic American** – Persons of Mexican, Puerto Rican, Cuban, Spanish or Central or South American origin.
- c. **Asian-Pacific American** – Persons having origins in any of the original peoples of the Far East, Southeast Asia, the Indian subcontinent or the Pacific Islands.
- d. **Asian-Indian American** – Persons whose origins are from India, Pakistan, Bangladesh or Sri Lanka.
- e. **American Indian/Native American** – Persons having no less than 1/16 percentage origin in any of the American Indian Tribes, as recognized by the U.S. Department of the Interior's Bureau of Indian Affairs and as demonstrated by possession of personal tribal role documents.

**Women Business Enterprise (WBE):** A business structure that is Certified by the Texas Comptroller's Office (HUB), or the South Central Texas Regional Certification Agency as being 51% owned, operated and controlled by a woman or women who are legally residing in or citizens of the United States.

**African American Business Enterprise (AABE):** A business structure that is Certified by the Texas Comptroller's Office (HUB), or the South Central Texas Regional Certification Agency as being 51% owned, operated and controlled by African American minority group member(s) who are legally residing in or are citizens of the United States.

**Joint Venture:** A limited association of two or more persons to carry out a single business enterprise for profit, for which purpose they combine their property, money, efforts, skills and knowledge.

**Veteran-Owned Business Enterprise (VBE):** A business structure that is at least 51% owned, operated and controlled by an individual who served in the United States Armed Forces, and who was discharged or released under conditions other than dishonorable. Please note: This certification type should not be confused with the Service Disabled Veteran designation available through the Small Business Administration.

**Web Submittal of Subcontractor Payment Reports:**

The Contractor will be required to electronically report the actual payments to all subcontractors, utilizing the Subcontractor Payment and Utilization Reporting (S.P.U.R.) System, beginning with the first SAWS payment for services under the contract, and with every payment thereafter (for the duration of the contract). Electronic submittal of monthly subcontractor payment information will be accessed through a link on SAWS' "Business Center" web page. This information will be utilized for subcontractor participation tracking purposes. Any unjustified failure to comply with the committed SMWB levels may be considered breach of contract.

The Contractor and all subcontractors will be provided a unique log-in credential and password to access the SAWS subcontractor payment reporting system. The link may also be accessed through the following internet address: <https://saws.smwbe.com/>

# CONFLICT OF INTEREST QUESTIONNAIRE

For vendor doing business with local governmental entity

## FORM CIQ

This questionnaire reflects changes made to the law by H.B. 23, 84th Leg., Regular Session.

This questionnaire is being filed in accordance with Chapter 176, Local Government Code, by a vendor who has a business relationship as defined by Section 176.001(1-a) with a local governmental entity and the vendor meets requirements under Section 176.006(a).

By law this questionnaire must be filed with the records administrator of the local governmental entity not later than the 7th business day after the date the vendor becomes aware of facts that require the statement to be filed. See Section 176.006(a-1), Local Government Code.

A vendor commits an offense if the vendor knowingly violates Section 176.006, Local Government Code. An offense under this section is a misdemeanor.

### OFFICE USE ONLY

Date Received

**1** Name of vendor who has a business relationship with local governmental entity.

**2**  Check this box if you are filing an update to a previously filed questionnaire. (The law requires that you file an updated completed questionnaire with the appropriate filing authority not later than the 7th business day after the date on which you became aware that the originally filed questionnaire was incomplete or inaccurate.)

**3** Name of local government officer about whom the information is being disclosed.

\_\_\_\_\_  
Name of Officer

**4** Describe each employment or other business relationship with the local government officer, or a family member of the officer, as described by Section 176.003(a)(2)(A). Also describe any family relationship with the local government officer. Complete subparts A and B for each employment or business relationship described. Attach additional pages to this Form CIQ as necessary.

A. Is the local government officer or a family member of the officer receiving or likely to receive taxable income, other than investment income, from the vendor?

Yes       No

B. Is the vendor receiving or likely to receive taxable income, other than investment income, from or at the direction of the local government officer or a family member of the officer AND the taxable income is not received from the local governmental entity?

Yes       No

**5** Describe each employment or business relationship that the vendor named in Section 1 maintains with a corporation or other business entity with respect to which the local government officer serves as an officer or director, or holds an ownership interest of one percent or more.

**6**  Check this box if the vendor has given the local government officer or a family member of the officer one or more gifts as described in Section 176.003(a)(2)(B), excluding gifts described in Section 176.003(a-1).

**7**

\_\_\_\_\_  
Signature of vendor doing business with the governmental entity

\_\_\_\_\_  
Date

## **CONFLICT OF INTEREST QUESTIONNAIRE**

### **For vendor doing business with local governmental entity**

A complete copy of Chapter 176 of the Local Government Code may be found at <http://www.statutes.legis.state.tx.us/Docs/LG/htm/LG.176.htm>. For easy reference, below are some of the sections cited on this form.

**Local Government Code § 176.001(1-a):** "Business relationship" means a connection between two or more parties based on commercial activity of one of the parties. The term does not include a connection based on:

- (A) a transaction that is subject to rate or fee regulation by a federal, state, or local governmental entity or an agency of a federal, state, or local governmental entity;
- (B) a transaction conducted at a price and subject to terms available to the public; or
- (C) a purchase or lease of goods or services from a person that is chartered by a state or federal agency and that is subject to regular examination by, and reporting to, that agency.

**Local Government Code § 176.003(a)(2)(A) and (B):**

(a) A local government officer shall file a conflicts disclosure statement with respect to a vendor if:

\*\*\*

(2) the vendor:

(A) has an employment or other business relationship with the local government officer or a family member of the officer that results in the officer or family member receiving taxable income, other than investment income, that exceeds \$2,500 during the 12-month period preceding the date that the officer becomes aware that

- (i) a contract between the local governmental entity and vendor has been executed;
- or
- (ii) the local governmental entity is considering entering into a contract with the vendor;

(B) has given to the local government officer or a family member of the officer one or more gifts that have an aggregate value of more than \$100 in the 12-month period preceding the date the officer becomes aware that:

- (i) a contract between the local governmental entity and vendor has been executed; or
- (ii) the local governmental entity is considering entering into a contract with the vendor.

**Local Government Code § 176.006(a) and (a-1)**

(a) A vendor shall file a completed conflict of interest questionnaire if the vendor has a business relationship with a local governmental entity and:

- (1) has an employment or other business relationship with a local government officer of that local governmental entity, or a family member of the officer, described by Section 176.003(a)(2)(A);
- (2) has given a local government officer of that local governmental entity, or a family member of the officer, one or more gifts with the aggregate value specified by Section 176.003(a)(2)(B), excluding any gift described by Section 176.003(a-1); or
- (3) has a family relationship with a local government officer of that local governmental entity.

(a-1) The completed conflict of interest questionnaire must be filed with the appropriate records administrator not later than the seventh business day after the later of:

(1) the date that the vendor:

- (A) begins discussions or negotiations to enter into a contract with the local governmental entity; or
- (B) submits to the local governmental entity an application, response to a request for proposals or bids, correspondence, or another writing related to a potential contract with the local governmental entity; or

(2) the date the vendor becomes aware:

- (A) of an employment or other business relationship with a local government officer, or a family member of the officer, described by Subsection (a);
- (B) that the vendor has given one or more gifts described by Subsection (a); or
- (C) of a family relationship with a local government officer.



General Decision Number: TX190007 01/04/2019 TX7

Superseded General Decision Number: TX20180016

State: Texas

Construction Types: Heavy and Highway

Counties: Atascosa, Bandera, Bastrop, Bell, Bexar, Brazos, Burleson, Caldwell, Comal, Coryell, Guadalupe, Hays, Kendall, Lampasas, McLennan, Medina, Robertson, Travis, Williamson and Wilson Counties in Texas.

HEAVY (excluding tunnels and dams, not to be used for work on Sewage or Water Treatment Plants or Lift / Pump Stations in Bell, Coryell, McClellon and Williamson Counties) and HIGHWAY Construction Projects

Note: Under Executive Order (EO) 13658, an hourly minimum wage of \$10.60 for calendar year 2019 applies to all contracts subject to the Davis-Bacon Act for which the contract is awarded (and any solicitation was issued) on or after January 1, 2015. If this contract is covered by the EO, the contractor must pay all workers in any classification listed on this wage determination at least \$10.60 per hour (or the applicable wage rate listed on this wage determination, if it is higher) for all hours spent performing on the contract in calendar year 2019. If this contract is covered by the EO and a classification considered necessary for performance of work on the contract does not appear on this wage determination, the contractor must pay workers in that classification at least the wage rate determined through the conformance process set forth in 29 CFR 5.5(a)(1)(ii) (or the EO minimum wage rate, if it is higher than the conformed wage rate). The EO minimum wage rate will be adjusted annually. Please note that this EO applies to the above-mentioned types of contracts entered into by the federal government that are subject to the Davis-Bacon Act itself, but it does not apply to contracts subject only to the Davis-Bacon Related Acts, including those set forth at 29 CFR 5.1(a)(2)-(60). Additional information on contractor requirements and worker protections under the EO is available at [www.dol.gov/whd/govcontracts](http://www.dol.gov/whd/govcontracts).

|                     |                  |
|---------------------|------------------|
| Modification Number | Publication Date |
| 0                   | 01/04/2019       |

\* SUTX2011-006 08/03/2011

|       |         |
|-------|---------|
| Rates | Fringes |
|-------|---------|

CEMENT MASON/CONCRETE  
FINISHER (Paving and

|   |          |
|---|----------|
| Structures).....                            | \$ 12.56 |
| ELECTRICIAN.....                            | \$ 26.35 |
| FORM BUILDER/FORM SETTER                    |          |
| Paving & Curb.....                          | \$ 12.94 |
| Structures.....                             | \$ 12.87 |
| LABORER                                     |          |
| Asphalt Raker.....                          | \$ 12.12 |
| Flagger.....                                | \$ 9.45  |
| Laborer, Common.....                        | \$ 10.50 |
| Laborer, Utility.....                       | \$ 12.27 |
| Pipelayer.....                              | \$ 12.79 |
| Work Zone Barricade<br>Servicer.....        | \$ 11.85 |
| PAINTER (Structures).....                   | \$ 18.34 |
| POWER EQUIPMENT OPERATOR:                   |          |
| Agricultural Tractor.....                   | \$ 12.69 |
| Asphalt Distributor.....                    | \$ 15.55 |
| Asphalt Paving Machine.....                 | \$ 14.36 |
| Boom Truck.....                             | \$ 18.36 |
| Broom or Sweeper.....                       | \$ 11.04 |
| Concrete Pavement<br>Finishing Machine..... | \$ 15.48 |
| Crane, Hydraulic 80 tons<br>or less.....    | \$ 18.36 |
| Crane, Lattice Boom 80<br>tons or less..... | \$ 15.87 |
| Crane, Lattice Boom over<br>80 tons.....    | \$ 19.38 |
| Crawler Tractor.....                        | \$ 15.67 |
| Directional Drilling<br>Locator.....        | \$ 11.67 |
| Directional Drilling<br>Operator.....       | \$ 17.24 |
| Excavator 50,000 lbs or<br>Less.....        | \$ 12.88 |
| Excavator over 50,000 lbs...                | \$ 17.71 |
| Foundation Drill, Truck<br>Mounted.....     | \$ 16.93 |
| Front End Loader, 3 CY or<br>Less.....      | \$ 13.04 |
| Front End Loader, Over 3 CY.                | \$ 13.21 |
| Loader/Backhoe.....                         | \$ 14.12 |
| Mechanic.....                               | \$ 17.10 |
| Milling Machine.....                        | \$ 14.18 |
| Motor Grader, Fine Grade....                | \$ 18.51 |
| Motor Grader, Rough.....                    | \$ 14.63 |
| Pavement Marking Machine....                | \$ 19.17 |
| Reclaimer/Pulverizer.....                   | \$ 12.88 |
| Roller, Asphalt.....                        | \$ 12.78 |
| Roller, Other.....                          | \$ 10.50 |
| Scraper.....                                | \$ 12.27 |
| Spreader Box.....                           | \$ 14.04 |

Trenching Machine, Heavy....\$ 18.48

Servicer.....\$ 14.51

Steel Worker

    Reinforcing.....\$ 14.00

    Structural.....\$ 19.29

TRAFFIC SIGNAL INSTALLER

    Traffic Signal/Light Pole

    Worker.....\$ 16.00

TRUCK DRIVER

    Lowboy-Float.....\$ 15.66

    Off Road Hauler.....\$ 11.88

    Single Axle.....\$ 11.79

    Single or Tandem Axle Dump

    Truck.....\$ 11.68

    Tandem Axle Tractor w/Semi

    Trailer.....\$ 12.81

WELDER.....\$ 15.97

---

WELDERS - Receive rate prescribed for craft performing operation to which welding is incidental.

---

Note: Executive Order (EO) 13706, Establishing Paid Sick Leave for Federal Contractors applies to all contracts subject to the Davis-Bacon Act for which the contract is awarded (and any solicitation was issued) on or after January 1, 2017. If this contract is covered by the EO, the contractor must provide employees with 1 hour of paid sick leave for every 30 hours they work, up to 56 hours of paid sick leave each year. Employees must be permitted to use paid sick leave for their own illness, injury or other health-related needs, including preventive care; to assist a family member (or person who is like family to the employee) who is ill, injured, or has other health-related needs, including preventive care; or for reasons resulting from, or to assist a family member (or person who is like family to the employee) who is a victim of, domestic violence, sexual assault, or stalking. Additional information on contractor requirements and worker protections under the EO is available at [www.dol.gov/whd/govcontracts](http://www.dol.gov/whd/govcontracts).

Unlisted classifications needed for work not included within the scope of the classifications listed may be added after award only as provided in the labor standards contract clauses (29CFR 5.5 (a) (1) (ii)).

---

The body of each wage determination lists the classification

and wage rates that have been found to be prevailing for the cited type(s) of construction in the area covered by the wage determination. The classifications are listed in alphabetical order of "identifiers" that indicate whether the particular rate is a union rate (current union negotiated rate for local), a survey rate (weighted average rate) or a union average rate (weighted union average rate).

#### Union Rate Identifiers

A four letter classification abbreviation identifier enclosed in dotted lines beginning with characters other than "SU" or "UAVG" denotes that the union classification and rate were prevailing for that classification in the survey. Example: PLUM0198-005 07/01/2014. PLUM is an abbreviation identifier of the union which prevailed in the survey for this classification, which in this example would be Plumbers. 0198 indicates the local union number or district council number where applicable, i.e., Plumbers Local 0198. The next number, 005 in the example, is an internal number used in processing the wage determination. 07/01/2014 is the effective date of the most current negotiated rate, which in this example is July 1, 2014.

Union prevailing wage rates are updated to reflect all rate changes in the collective bargaining agreement (CBA) governing this classification and rate.

#### Survey Rate Identifiers

Classifications listed under the "SU" identifier indicate that no one rate prevailed for this classification in the survey and the published rate is derived by computing a weighted average rate based on all the rates reported in the survey for that classification. As this weighted average rate includes all rates reported in the survey, it may include both union and non-union rates. Example: SULA2012-007 5/13/2014. SU indicates the rates are survey rates based on a weighted average calculation of rates and are not majority rates. LA indicates the State of Louisiana. 2012 is the year of survey on which these classifications and rates are based. The next number, 007 in the example, is an internal number used in producing the wage determination. 5/13/2014 indicates the survey completion date for the classifications and rates under that identifier.

Survey wage rates are not updated and remain in effect until a new survey is conducted.

#### Union Average Rate Identifiers

Classification(s) listed under the UAVG identifier indicate that no single majority rate prevailed for those classifications; however, 100% of the data reported for the classifications was union data. EXAMPLE: UAVG-OH-0010 08/29/2014. UAVG indicates that the rate is a weighted union average rate. OH indicates the state. The next number, 0010 in the example, is an internal number used in producing the wage

determination. 08/29/2014 indicates the survey completion date for the classifications and rates under that identifier.

A UAVG rate will be updated once a year, usually in January of each year, to reflect a weighted average of the current negotiated/CBA rate of the union locals from which the rate is based.

---

WAGE DETERMINATION APPEALS PROCESS

1.) Has there been an initial decision in the matter? This can be:

- \* an existing published wage determination
- \* a survey underlying a wage determination
- \* a Wage and Hour Division letter setting forth a position on a wage determination matter
- \* a conformance (additional classification and rate) ruling

On survey related matters, initial contact, including requests for summaries of surveys, should be with the Wage and Hour Regional Office for the area in which the survey was conducted because those Regional Offices have responsibility for the Davis-Bacon survey program. If the response from this initial contact is not satisfactory, then the process described in 2.) and 3.) should be followed.

With regard to any other matter not yet ripe for the formal process described here, initial contact should be with the Branch of Construction Wage Determinations. Write to:

Branch of Construction Wage Determinations  
Wage and Hour Division  
U.S. Department of Labor  
200 Constitution Avenue, N.W.  
Washington, DC 20210

2.) If the answer to the question in 1.) is yes, then an interested party (those affected by the action) can request review and reconsideration from the Wage and Hour Administrator (See 29 CFR Part 1.8 and 29 CFR Part 7). Write to:

Wage and Hour Administrator  
U.S. Department of Labor  
200 Constitution Avenue, N.W.  
Washington, DC 20210

The request should be accompanied by a full statement of the interested party's position and by any information (wage payment data, project description, area practice material, etc.) that the requestor considers relevant to the issue.

3.) If the decision of the Administrator is not favorable, an

interested party may appeal directly to the Administrative Review Board (formerly the Wage Appeals Board). Write to:

Administrative Review Board  
U.S. Department of Labor  
200 Constitution Avenue, N.W.  
Washington, DC 20210

4.) All decisions by the Administrative Review Board are final.

=====

END OF GENERAL DECISION

"General Decision Number: TX20190231 08/02/2019

Superseded General Decision Number: TX20180280

State: Texas

Construction Type: Building

County: Bexar County in Texas.

BUILDING CONSTRUCTION PROJECTS (does not include single family homes or apartments up to and including 4 stories).

Note: Under Executive Order (EO) 13658, an hourly minimum wage of \$10.60 for calendar year 2019 applies to all contracts subject to the Davis-Bacon Act for which the contract is awarded (and any solicitation was issued) on or after January 1, 2015. If this contract is covered by the EO, the contractor must pay all workers in any classification listed on this wage determination at least \$10.60 per hour (or the applicable wage rate listed on this wage determination, if it is higher) for all hours spent performing on the contract in calendar year 2019. If this contract is covered by the EO and a classification considered necessary for performance of work on the contract does not appear on this wage determination, the contractor must pay workers in that classification at least the wage rate determined through the conformance process set forth in 29 CFR 5.5(a)(1)(ii) (or the EO minimum wage rate, if it is higher than the conformed wage rate). The EO minimum wage rate will be adjusted annually. Please note that this EO applies to the above-mentioned types of contracts entered into by the federal government that are subject to the Davis-Bacon Act itself, but it does not apply to contracts subject only to the

Davis-Bacon Related Acts, including those set forth at 29 CFR 5.1(a)(2)-(60). Additional information on contractor requirements and worker protections under the EO is available at [www.dol.gov/whd/govcontracts](http://www.dol.gov/whd/govcontracts).

| Modification Number | Publication Date |
|---------------------|------------------|
| 0                   | 01/04/2019       |
| 1                   | 01/18/2019       |
| 2                   | 08/02/2019       |

ASBE0087-014 01/01/2018

|   | Rates    | Fringes |
|---|----------|---------|
| ASBESTOS WORKER/HEAT & FROST<br>INSULATOR (Duct, Pipe and<br>Mechanical System Insulation)..... | \$ 22.72 | 10.02   |

BOIL0074-003 01/01/2017

|                  | Rates    | Fringes |
|------------------|----------|---------|
| BOILERMAKER..... | \$ 28.00 | 22.35   |

\* ELEC0060-003 06/01/2019

|   | Rates    | Fringes |
|---|----------|---------|
| ELECTRICIAN (Communication<br>Technician Only)..... | \$ 22.55 | 9%+5.45 |

\* ELEC0060-004 07/01/2019

|                           | Rates | Fringes |
|---------------------------|-------|---------|
| ELECTRICIAN (Excludes Low |       |         |



Voltage Wiring).....\$ 28.60                    20%+5.45

-----

ELEV0081-001 01/01/2019

                                 Rates                    Fringes

ELEVATOR MECHANIC.....\$ 40.57                    33.705

FOOTNOTES:

A. 6% under 5 years based on regular hourly rate for all hours worked. 8% over 5 years based on regular hourly rate for all hours worked.

B. Holidays: New Year's Day; Memorial Day; Independence Day; Labor Day; Thanksgiving Day; Friday after Thanksgiving Day; Christmas Day; and Veterans Day.

-----

ENGI0450-002 04/01/2014

                                 Rates                    Fringes

POWER EQUIPMENT OPERATOR

    Cranes.....\$ 34.85                    9.85

-----

IRON0066-013 09/01/2018

                                 Rates                    Fringes

IRONWORKER, STRUCTURAL.....\$ 22.05                    6.73

-----

IRON0084-011 06/01/2018

                                 Rates                    Fringes

IRONWORKER, ORNAMENTAL.....\$ 23.77                    7.12

-----

\* PLUM0142-009 07/01/2017

|  | Rates    | Fringes |
|--|----------|---------|
| HVAC MECHANIC (HVAC<br>Electrical Temperature<br>Control Installation Only)..... | \$ 30.25 | 13.36   |
| HVAC MECHANIC (HVAC Unit<br>Installation Only).....                              | \$ 30.25 | 13.36   |
| PIPEFITTER (Including HVAC<br>Pipe Installation).....                            | \$ 30.25 | 13.36   |
| PLUMBER (Excludes HVAC Pipe<br>Installation).....                                | \$ 30.25 | 13.36   |

-----  
SFTX0669-002 04/01/2017

|  | Rates    | Fringes |
|--|----------|---------|
| SPRINKLER FITTER (Fire<br>Sprinklers)..... | \$ 29.03 | 15.84   |

-----  
\* SHEE0067-004 06/01/2019

|   | Rates    | Fringes |
|---|----------|---------|
| Sheet metal worker<br>Excludes HVAC Duct<br>Installation..... | \$ 26.81 | 16.80   |
| HVAC Duct Installation Only.                                  | \$ 26.81 | 16.80   |

-----  
SUTX2014-006 07/21/2014

|                 | Rates    | Fringes |
|-----------------|----------|---------|
| BRICKLAYER..... | \$ 22.15 | 0.00    |

CARPENTER (Acoustical Ceiling

|   |      |
|---|------|
| Installation Only).....\$ 17.83   | 0.00 |
| CARPENTER (Form Work Only).....\$ 13.63   | 0.00 |
| CARPENTER, Excludes<br>Acoustical Ceiling<br>Installation, Drywall<br>Hanging, Form Work, and Metal<br>Stud Installation.....\$ 16.86 | 4.17 |
| CAULKER.....\$ 15.00  | 0.00 |
| CEMENT MASON/CONCRETE FINISHER...\$ 22.27   | 5.30 |
| DRYWALL FINISHER/TAPER.....\$ 13.81   | 0.00 |
| DRYWALL HANGER AND METAL STUD<br>INSTALLER.....\$ 15.18   | 0.00 |
| ELECTRICIAN (Low Voltage<br>Wiring Only).....\$ 20.39   | 3.04 |
| IRONWORKER, REINFORCING.....\$ 12.27  | 0.00 |
| LABORER: Common or General.....\$ 10.75   | 0.00 |
| LABORER: Mason Tender - Brick...\$ 11.88  | 0.00 |
| LABORER: Mason Tender -<br>Cement/Concrete.....\$ 12.00   | 0.00 |
| LABORER: Pipelayer.....\$ 11.00   | 0.00 |
| LABORER: Roof Tearoff.....\$ 11.28  | 0.00 |
| LABORER: Landscape and<br>Irrigation.....\$ 8.00  | 0.00 |

|   |          |      |
|---|----------|------|
| OPERATOR:   |          |      |
| Backhoe/Excavator/Trackhoe.....   | \$ 15.98 | 0.00 |
| OPERATOR: Bobcat/Skid   |          |      |
| Steer/Skid Loader.....  | \$ 14.00 | 0.00 |
| OPERATOR: Bulldozer.....  | \$ 14.00 | 0.00 |
| OPERATOR: Drill.....  | \$ 14.50 | 0.00 |
| OPERATOR: Forklift.....   | \$ 12.50 | 0.00 |
| OPERATOR: Grader/Blade.....   | \$ 23.00 | 5.07 |
| OPERATOR: Loader.....   | \$ 12.79 | 0.00 |
| OPERATOR: Mechanic.....   | \$ 18.75 | 5.12 |
| OPERATOR: Paver (Asphalt,<br>Aggregate, and Concrete).....                      | \$ 16.03 | 0.00 |
| OPERATOR: Roller.....   | \$ 12.00 | 0.00 |
| PAINTER (Brush, Roller and<br>Spray), Excludes Drywall<br>Finishing/Taping..... | \$ 13.07 | 0.00 |
| ROOFER.....   | \$ 12.00 | 0.00 |
| TILE FINISHER.....  | \$ 11.32 | 0.00 |
| TILE SETTER.....  | \$ 14.94 | 0.00 |
| TRUCK DRIVER: Dump Truck.....   | \$ 12.39 | 1.18 |
| TRUCK DRIVER: Flatbed Truck.....  | \$ 19.65 | 8.57 |

TRUCK DRIVER: Semi-Trailer

Truck.....\$ 12.50 0.00

TRUCK DRIVER: Water Truck.....\$ 12.00 4.11

-----  
WELDERS - Receive rate prescribed for craft performing operation to which welding is incidental.

=====  
Note: Executive Order (EO) 13706, Establishing Paid Sick Leave for Federal Contractors applies to all contracts subject to the Davis-Bacon Act for which the contract is awarded (and any solicitation was issued) on or after January 1, 2017. If this contract is covered by the EO, the contractor must provide employees with 1 hour of paid sick leave for every 30 hours they work, up to 56 hours of paid sick leave each year. Employees must be permitted to use paid sick leave for their own illness, injury or other health-related needs, including preventive care; to assist a family member (or person who is like family to the employee) who is ill, injured, or has other health-related needs, including preventive care; or for reasons resulting from, or to assist a family member (or person who is like family to the employee) who is a victim of, domestic violence, sexual assault, or stalking. Additional information on contractor requirements and worker protections under the EO is available at [www.dol.gov/whd/govcontracts](http://www.dol.gov/whd/govcontracts).

Unlisted classifications needed for work not included within the scope of the classifications listed may be added after award only as provided in the labor standards contract clauses (29CFR 5.5 (a) (1) (ii)).

The body of each wage determination lists the classification and wage rates that have been found to be prevailing for the cited type(s) of construction in the area covered by the wage determination. The classifications are listed in alphabetical order of ""identifiers"" that indicate whether the particular rate is a union rate (current union negotiated rate for local), a survey rate (weighted average rate) or a union average rate (weighted union average rate).

#### Union Rate Identifiers

A four letter classification abbreviation identifier enclosed in dotted lines beginning with characters other than ""SU"" or ""UAVG"" denotes that the union classification and rate were prevailing for that classification in the survey. Example: PLUM0198-005 07/01/2014. PLUM is an abbreviation identifier of the union which prevailed in the survey for this classification, which in this example would be Plumbers. 0198 indicates the local union number or district council number where applicable, i.e., Plumbers Local 0198. The next number, 005 in the example, is an internal number used in processing the wage determination. 07/01/2014 is the effective date of the most current negotiated rate, which in this example is July 1, 2014.

Union prevailing wage rates are updated to reflect all rate changes in the collective bargaining agreement (CBA) governing this classification and rate.

#### Survey Rate Identifiers

Classifications listed under the ""SU"" identifier indicate that no one rate prevailed for this classification in the survey and the published rate is derived by computing a weighted average rate based on all the rates reported in the survey for that

classification. As this weighted average rate includes all rates reported in the survey, it may include both union and non-union rates. Example: SULA2012-007 5/13/2014. SU indicates the rates are survey rates based on a weighted average calculation of rates and are not majority rates. LA indicates the State of Louisiana. 2012 is the year of survey on which these classifications and rates are based. The next number, 007 in the example, is an internal number used in producing the wage determination. 5/13/2014 indicates the survey completion date for the classifications and rates under that identifier.

Survey wage rates are not updated and remain in effect until a new survey is conducted.

#### Union Average Rate Identifiers

Classification(s) listed under the UAVG identifier indicate that no single majority rate prevailed for those classifications; however, 100% of the data reported for the classifications was union data. EXAMPLE: UAVG-OH-0010 08/29/2014. UAVG indicates that the rate is a weighted union average rate. OH indicates the state. The next number, 0010 in the example, is an internal number used in producing the wage determination. 08/29/2014 indicates the survey completion date for the classifications and rates under that identifier.

A UAVG rate will be updated once a year, usually in January of each year, to reflect a weighted average of the current negotiated/CBA rate of the union locals from which the rate is based.

---

WAGE DETERMINATION APPEALS PROCESS

1.) Has there been an initial decision in the matter? This can be:

- \* an existing published wage determination
- \* a survey underlying a wage determination
- \* a Wage and Hour Division letter setting forth a position on a wage determination matter
- \* a conformance (additional classification and rate) ruling

On survey related matters, initial contact, including requests for summaries of surveys, should be with the Wage and Hour Regional Office for the area in which the survey was conducted because those Regional Offices have responsibility for the Davis-Bacon survey program. If the response from this initial contact is not satisfactory, then the process described in 2.) and 3.) should be followed.

With regard to any other matter not yet ripe for the formal process described here, initial contact should be with the Branch of Construction Wage Determinations. Write to:

Branch of Construction Wage Determinations  
Wage and Hour Division  
U.S. Department of Labor  
200 Constitution Avenue, N.W.  
Washington, DC 20210

2.) If the answer to the question in 1.) is yes, then an interested party (those affected by the action) can request review and reconsideration from the Wage and Hour Administrator (See 29 CFR Part 1.8 and 29 CFR Part 7). Write to:

Wage and Hour Administrator  
U.S. Department of Labor  
200 Constitution Avenue, N.W.  
Washington, DC 20210



The request should be accompanied by a full statement of the interested party's position and by any information (wage payment data, project description, area practice material, etc.) that the requestor considers relevant to the issue.

3.) If the decision of the Administrator is not favorable, an interested party may appeal directly to the Administrative Review Board (formerly the Wage Appeals Board). Write to:

Administrative Review Board  
U.S. Department of Labor  
200 Constitution Avenue, N.W.  
Washington, DC 20210

4.) All decisions by the Administrative Review Board are final.

=====

END OF GENERAL DECISION"

**SAN ANTONIO WATER SYSTEM**

**GENERAL CONDITIONS  
(Revised June 2015)**

**CONTENTS**

| <b>Article</b> | <b>Title</b>                                      | <b>Page</b>  |
|----------------|---|--------------|
| <b>I.</b>      | <b>Contract Definitions</b>                       | <b>GC-2</b>  |
| <b>II.</b>     | <b>Legal Relationships &amp; Responsibilities</b> | <b>GC-7</b>  |
| <b>III.</b>    | <b>Contract Documents &amp; Bonds</b>             | <b>GC-10</b> |
| <b>IV.</b>     | <b>Contract Administration</b>                    | <b>GC-12</b> |
| <b>V.</b>      | <b>Contract Responsibilities</b>                  | <b>GC-20</b> |
| <b>VI.</b>     | <b>Contract Changes</b>                           | <b>GC-39</b> |
| <b>VII.</b>    | <b>Contract Payments</b>                          | <b>GC-44</b> |
| <b>VIII.</b>   | <b>Contract Completion Time</b>                   | <b>GC-46</b> |
| <b>IX.</b>     | <b>Project Completion and Acceptance</b>          | <b>GC-48</b> |
| <b>X.</b>      | <b>Disputes</b>                                   | <b>GC-50</b> |
| <b>XI.</b>     | <b>Supplemental and Special Conditions</b>        | <b>GC-50</b> |
| <b>XII.</b>    | <b>Right to Audit Clause</b>                      | <b>GC-51</b> |
| <b>XIII.</b>   | <b>Venue</b>                                      | <b>GC-51</b> |

# SAN ANTONIO WATER SYSTEM

## GENERAL CONDITIONS

### ARTICLE I. CONTRACT DEFINITIONS:

Wherever in these General Conditions or in other parts of the Contract Documents, the following terms, or pronouns in place of them are used, the intent and meaning shall be interpreted as follows:

1. ACPA - American Concrete Pipe Association.
2. ANSI - American National Standards Institute.
3. ASTM - American Society for Testing Materials.
4. AUTHORIZATION TO PROCEED - (Work Project Authorization) A written notice given by Owner to Contractor establishing the date on which the Contract Time will commence to run and on which Contractor shall start to perform Contractor's obligations under the Contract Documents.
5. AWWA - American Water Works Association.
6. BIDDER - An individual, partnership, corporation, joint venture, etc., submitting a proposal.
7. BOARD - Board of Trustees of the San Antonio Water System.
8. CHANGE ORDER - A written order issued by the Owner to the Contractor authorizing additions, deletions, or revisions to the Work to be performed by the Contractor within the scope of construction services outlined in the Contract Documents. This includes changes in price and/or changes in time.
9. CITY- The City of San Antonio, Texas (COSA)
10. CITY COUNCIL - The duly elected members of the council of the City of San Antonio, Texas.
11. CLAIM - A written demand seeking, as a matter of right, adjustment or interpretation of Contract terms, payment of money, extension of time or other relief with respect to the terms of the Contract.
12. COMPETENT PERSON - Employee of prime Contractor who has the industry knowledge of construction safety practices and is well versed with construction practices and procedures.
13. CONDITIONAL LETTER OF ACCEPTANCE - The date certified in writing by the Owner when the Construction of the entire Project or any completed portions thereof as defined by SAWS is completed in accordance with the Contract Documents.
14. CONSTRUCTION OBSERVER/INSPECTOR (COI) - The Owners assigned authorized representative who observes, inspects, and may accept any or all parts of the Project and the materials to be used therein.
15. CONSULTANT - A person registered as a professional engineer pursuant to Texas Occupations Code, Title 6, Chapter 1001, employed to provide professional engineering services and having overall responsibility for the design of a project or a significant portion thereof, together with administrative supervision of any subconsultants the Consultant may retain. The term "Consultant", unless the context clearly indicates otherwise, means an engineer in private practice retained for a specific project under a contractual agreement with the Owner.
16. CONTRACT - The signatory Agreement (Standard Form) between the SAWS and the Contractor governing the furnishing of material and performance of the Work. The Contract will include all Contract Documents.

17. CONTRACT DOCUMENTS - The Contract Documents consist of Bidding or Proposal Documents (Invitation to Bidder's or Invitation for Competitive Sealed Proposals, the Instructions to Bidders or the Instructions to Respondents, the Supplementary Instructions to Respondents, the Contractor's completed Bid Proposal or Price Proposal form, the Addenda), the Contract, the Conditions of the Contract (General, Supplemental and Special Conditions), the Standard Drawings, the Construction Specifications, the Change Orders, the Payment and Performance Bonds, and the Good Faith Effort Plan. The Contract Documents form the complete CONTRACT, which represents the entire and integrated agreement between the Owner and the Contractor and supersedes all prior negotiations, representations, or agreements, either written or oral. The Contract Documents shall not be construed to create a contractual relationship of any kind between:
  - (1) Design Consultant and Contractor;
  - (2) Owner and Subcontractor or Subcontractor; or
  - (3) Any person or entities other than Owner and Contractor.
18. CONTRACTOR - The individual, partnership, corporation, joint venture, or other entity contracting with the SAWS to complete the Work. The Contractor is directly responsible for the Subcontractors and Vendors that they select to complete the Work.
19. CONTRACT SUM - The total compensation payable to the Contractor for performing the Work as originally contracted or as subsequently adjusted by Change Orders.
20. CONTRACT TIME - The total time allowed the Contractor for completion of the Work. Contract Time will commence as per Article 8.1 and shall include the number of days set forth in the Contract plus any extended days granted under the provisions of Article 6.
21. ENGINEER - A Professional Engineer licensed by the State of Texas and duly authorized as a representative of the San Antonio Water System to provide professional engineering services on public works projects. Equivalent terms may include Engineer of Record, Program Engineer, Project Engineer, and/or Design Engineer.
22. FORCE ACCOUNT - a basis of payment for the direct performance of Work with payment based on the actual cost of the labor, equipment and materials furnished and consideration for overhead and profit as specifically provided for in Section 6.5.3 herein.
23. HAZARDOUS MATERIAL(S)/SUBSTANCE - Pursuant to Section 26.263 of the Water Code hazardous material means any substance or material designated as such by the administrator of the Environmental Protection Agency pursuant to the Comprehensive Environmental Response Compensation and Liability Act (42 U.S.C. Sec. 9601 et seq.), regulated pursuant to Section 311 of the Federal Clean Water Act (33 U.S.C. Sec. 1321 et seq.), or designated by the Commission and shall also include but not be limited to:
  - (1) any substance that, whether by its nature or its use, is subject to regulation or requires environmental investigation, monitoring, or remediation under any federal, state, or local environmental laws, rules, or regulations;
  - (2) any underground storage tanks, as defined in 42 U.S.C. Section 6991(1)(A)(I) (including those defined by Section 9001(1) of the 1984 Hazardous and Solid Waste Amendments to the Resource Conservation and Recovery Act, 42 U.S.C. Section 6901 et seq.;
  - (3) the Texas Water Code Annotated Section 26.344; and Title 30 of the Texas Administrative Code Sections 334.3 and 334.4), whether empty, filled or partially filled with any substance; and
  - (4) any other hazardous material, hazardous waste, hazardous substance, solid waste, and toxic substance as those or similar terms are defined under any federal, state, or local environmental laws, rules, or regulations.
24. INSTRUCTIONS TO BIDDERS - Owner Instructions of a general nature outlining the duties and responsibilities of a prospective bidder.

25. LABORATORY - The testing laboratories of the Owner or any other testing laboratory that may be designated or approved in writing by the Owner.
26. LABOR BURDEN – The cost paid by an employer for employing individuals above the salary actually paid and reflected in their payroll. These are limited to the following:
- Payroll Taxes – both Federal and State (FICA, FUTA, SUTA)
  - Paid Holidays, Vacation Leave and Sick Leave
  - Retirement/Pension Costs (401K, etc.)
  - Health Care
  - Life/AD&D Insurance
  - Workers Compensation Insurance
  - Long-Term Disability Insurance
  - Short-Term Disability Insurance
  - Bonuses, if paid to all employees regardless of company’s financial performance
  - Safety Training and Personal Protective Equipment (PPE) given to all employees
27. LUMP SUM– Price of an entire group of services, where no breakdown is given for individual items.
28. MAJOR BID ITEM - Any individual bid item submitted by Contractor whose total cost, as determined by multiplying the bid schedule line item quantity for that bid item by the Contract unit price also provided in that bid schedule line item, is equal to or greater than 5 percent of the original contract total amount. The preceding criteria notwithstanding, the Owner and Consultant **reserve the right** to identify or exclude specific bid items as being "Major" in the Special Conditions for each Project.
29. MINORITY BUSINESS ENTERPRISE - A business structure that is certified by the Small Business Administration, Texas State Comptroller’s Office or the South Central Texas Regional Certification Agency as being 51% owned, operated, and controlled by an ethnic minority group member(s) who is legally residing in or a citizen of the United States. The ethnic minority group members recognized by SAWS are African Americans, Hispanic Americans, Asian Americans, and Native Americans.
30. MUNICIPAL SEPARATE STORM SEWER SYSTEM (MS4) - A conveyance or system of conveyances (including roads with drainage systems, municipal streets catch basins, curbs, gutters, ditches, man-made channels or storm drains:
- .1 Owned or operated by a State, City, town, borough, county, district association or other public body (created by or pursuant to State law) having jurisdiction over disposal of sewage, industrial waters, storm water or other wastes including special districts under State law such as a sewer district, flood control district or drainage district or similar entity or a designated and approved management agency under Section 208 of the Clean Water Act that discharges to water of the United States;
  - .2 Designated or used for collection or conveying storm water.
  - .3 That is not part of a Publicly Owned Treatment Works (POTW) as defined at 40 CFR 122.2.
31. NEMA - National Electrical Manufacturers Association.
32. NFPA - National Fire Protection Association.
33. NON-HAZARDOUS MATERIAL(s)/SUBSTANCES - Any material(s)/substance(s) which is not designated as hazardous pursuant to Article I. 23 herein and the continued presence of such on the site is determined by the Owner's representative not to be detrimental to the completion of the Project.
34. NOTICE OF NON COMPLIANCE – Neglect of compliance; failure to comply.
35. OWNER - The San Antonio Water System (SAWS).
36. OWNER'S REPRESENTATIVE - The Owner’s duly authorized representative of the System.

37. PAYMENT BOND – In accordance with Chapter 2253 of the Texas Government Code as amended, the security furnished by the Contractor through the Surety in the full amount of the Contract Sum for the protection of all persons supplying labor and material in the prosecution of the Work who properly follow statutory requirements for perfecting claims against such security. If the Contract amount does not exceed \$25,000, a Payment Bond may not be required.
38. PERFORMANCE BOND - In accordance with Chapter 2253 of the Texas Government Code as amended, the security furnished by the Contractor through the Surety in the full amount of the Contract Sum as a guaranty that the Work will be faithfully performed and completed and that the Owner will be saved harmless from all costs and damages which the Owner may suffer by reason of the Contractor's default or failure to perform the Work. If the Contract amount does not exceed \$25,000, a Performance Bond may not be required.
39. PIPELINE PROJECT - Work site and Work elements related to a sanitary sewer, water, or recycle water pipeline with all appurtenances and construction to be performed thereon under the Contract.
40. PLANS - The Plans, drawings, details and supplemental drawings, or reproductions thereof, produced and sealed by the Consultant and/or Engineer and approved by the Owner, showing the location, character, dimensions and details of the Work and which are a part of the Contract. Plans include standard details issued and sealed by the Consultant and/or Engineer or his representative.
41. PROJECT – The total design and construction of Work performed under the Contract Documents and may be the whole or a part of the Project and which may include construction by Owner or by separate Contractors. All references in these General Conditions to or concerning the Work or the Site of the Work will use and or related to the term “Project,”(including Pipeline Projects) notwithstanding that the Work only may be a part of the Project.
42. PROPOSAL - The offer of the bidder, made out on the prescribed forms, giving prices for performing the work described in the Plans and Specifications.
43. PUNCH LIST – List of Work remaining to be completed before final acceptance of the Project.
44. REQUEST FOR INFORMATION (RFI) – Document submitted by Contractor requesting clarification on a particular bid item, scope of work or intent of the Contract.
45. REQUEST FOR PROPOSAL (RFP) - Document submitted by Contractor to SAWS or document submitted by SAWS to Contractor requesting changes to the Contract Document.
46. SAMPLES - Physical examples furnished by the Contractor to Owner to illustrate intended or anticipated materials, equipment or workmanship, and to assist Owner and Consultant in the establishment of workmanship and quality standards by which the Work will be judged.
47. SAN ANTONIO WATER SYSTEM - San Antonio Water System (SAWS) shall mean the San Antonio Water System Board of Trustees as established pursuant to Article 1115, Texas Revised Civil Statutes Annotated, and City of San Antonio Ordinance No. 75686. Whenever used in this Contract the term SAWS or Owner shall be, unless indicated otherwise, understood to mean the San Antonio Water System Board of Trustees, or its successors or any person or persons acting lawfully in an official capacity on behalf of the SAWS at such time and within the power and authority specifically delegated to him or them by this Contract.
48. SEQUENCE OF CONSTRUCTION - The logical and proper order in which the Contractor shall accomplish the Work as provided by Article 5.14 as directed by the Owner in stages and phases, as shown in the Contract Documents, unless Owner orders otherwise by a properly executed Change Order as provided herein.
49. SHOP DRAWINGS - Drawings, diagrams, illustrations, schedules, performance charts, brochures and other data which are furnished by the Contractor and prepared by Contractor, first-tier or sub-tier subcontractors, manufacturer, supplier or distributor, and which illustrates and details some portion of the Work. Shop Drawings shall be furnished to the Owner as submittals.

50. SMALL BUSINESS ENTERPRISE – A business structure that is Certified by the Small Business Administration, Texas State Comptroller’s Office or the South Central Texas Regional Certification Agency as being 51% owned, operated and controlled by someone who is legally residing in or a citizen of the United States, and the business structure meets the U.S. Small Business Administration’s (SBA) size standard for a small business within the appropriate industry category.
51. SMALL, MINORITY, AND WOMAN-OWNED BUSINESS - Hereinafter referred to as “SMWB”, includes all business structures Certified by the Small Business Administration, Texas State Comptroller’s Office, or the South Central Texas Regional Certification Agency that are 51% owned, operated, and controlled by a SMALL BUSINESS ENTERPRISE, a MINORITY BUSINESS ENTERPRISE, or WOMAN-OWNED BUSINESS ENTERPRISE
52. SPECIAL CONDITIONS – The part of the Contract Documents which add special requirements that apply to a specific project as defined in Article XI herein.
53. SPECIFICATIONS - The specific instructions to the Contractor that are provided in the Contract Document as to the requirements for materials, equipment, certain construction procedures, standards and quality of workmanship for the Work and performance of related services and other technical requirements and forming a part of the Contract.
54. SUBCONTRACTOR - The individual, firm, equipment vendor, or corporation, having a first tier subcontract with the prime or general Contractor, subject to the review of qualifications by the Consultant and the Owner's Representative, for the performance of a part of the Work. Sub-tier subcontractors must be identified by the subcontractors and be similarly subject to the review of qualifications by the Consultant and the Owner's Representative for the performance of a part of the Work.
55. SUBSTANTIAL COMPLETION - When construction of the project or a specified part thereof is sufficiently completed in accordance with the Contract Documents so that the Project, or specified part thereof could be utilized for the Owner's purposes for which it is intended.
56. SUPERINTENDENT - The Contractor’s onsite project representative whom the Contractor has authorized to communicate with the SAWS COI, pursuant to the terms of the Contract and as provided for in Section 5.4 herein.
57. SUPPLEMENTARY CONDITIONS - Shall be as defined in Article XI herein.
58. SURETY - The corporate body licensed to conduct business in the State of Texas that provides assurance that the Contractor, or his substitute will faithfully perform the Work covered by the Contract and make payment of any due, unpaid, eligible labor and supply claims arising there under and is in compliance with the provisions contained in Articles 3.4 and 3.5 herein.
59. UNDERGROUND FACILITIES - All pipelines, conduits, ducts, cables, wires, manholes, vaults, tanks, tunnels or other such facilities or attachments and appurtenances thereto, and any encasement containing such facilities which have been installed underground to furnish any of the following services or materials: electricity, gases, steam, liquid petroleum products, telephone or other communications, cable television, water, sewage and drainage removal, traffic or other control systems.
60. UNIT PRICE WORK - Work to be paid for by Owner on the basis of Contractor quoted unit prices in the Bid Proposal based upon Owner estimated quantities.
61. WOMAN BUSINESS ENTERPRISE – A business structure that is Certified by the Small Business Administration, Texas State Comptroller’s Office or the South Central Texas Regional Certification Agency as being 51% owned, operated and controlled by a woman or women who are legally residing in or citizens of the United States

62. WORK - The entire completed construction or the various separately identifiable parts thereof required necessary, proper or incidental and required or reasonably inferable, to produce, construct and fully complete the construction project in strict accordance with the requirements of the Contract Documents. Work is the result of Contractor performing services, furnishing labor and furnishing and incorporating materials and equipment into the construction, all as required by the Contract Documents.
63. WORK CHANGE DIRECTIVE – Shall be as defined in Article VI herein. Document utilized to memorialize minor changes in work as described in 6.2.2.
64. WRITTEN NOTICE – Any notice, payment, statement or demand required or permitted to be given under this Contract by either party to the other may be effected by personal delivery in writing or by facsimile transmission, email or by mail, postage prepaid, or by overnight delivery to an officer, management level employee or other designated representative of either party. Mailed or email notices shall be addressed to the parties at an address designated by each party, but each party may change its address by written notice in accordance with this section. Mailed notices shall be deemed received as of three (3) calendar days after mailing.

## **ARTICLE II. LEGAL RELATIONSHIPS AND RESPONSIBILITIES:**

- 2.1 LEGAL RESPONSIBILITIES - The Contractor in the performance of the Work shall comply with all pertinent Ordinances of the City of San Antonio (COSA), Regulations of the San Antonio Water System (SAWS), Laws of the State of Texas, and of the United States, including but not limited to Rules and Regulations of the United States Department of Labor, pertaining to Occupational Safety and Health Administration standards as presently existing or as may hereinafter be modified or amended.
  - .1 Where construction projects cross or run along state highways, the Contractor shall at a minimum comply with governing Texas Department of Transportation Regulations as outlined in State Permits for each crossing. In cases where State Regulations do not apply, City Regulations shall be binding.
  - .2 Where construction projects cross or run along county roads, the Contractor shall at a minimum comply with governing Bexar County Public Works Regulations as outlined in the County Permit for each crossing.
- 2.2 GENERAL UNDERSTANDING - Contractor at his own cost and expense shall furnish all supervision, tools, implements, machinery, labor, materials and accessories, such as are necessary and proper for the purpose, and secure all required permits and licenses, and shall at his own cost and expense construct, build and complete, in a good, first class, substantial and workmanlike manner, the structures, work and improvements herein described and/or referred to in the Contract Documents.
- 2.3 INDEMNIFICATION - Contractor shall protect the public, SAWS, and COSA fully by taking reasonable precaution to safeguard persons from death or bodily injury and to safeguard property of any nature whatsoever from damage. Where any dangerous condition or nuisance exists in and around construction sites, equipment and supply storage areas and other areas in any way connected with the performance of this contract, the Contractor shall provide and maintain reasonable warning of such danger or nuisance. The Contractor shall not create an excavation, obstruction, or any dangerous condition or nuisance of any nature whatsoever in connection with the performance of this Contract unless necessary to its performance, and in that event the Contractor shall provide and maintain at all times any and all reasonable means of warning of any danger or nuisance created. The duties of the Contractor in this section shall be nondelegable, and the Contractor's compliance with the specific recommendations and requirements of the San Antonio Water System or the City of San Antonio as to the means of warning shall not excuse the Contractor from the faithful performance of these duties should such recommendations and requirements not be adequate or reasonable under the circumstances.

In order to protect SAWS and COSA the Contractor's failure to perform any of the foregoing duties or any of the terms of this Contract, the Contractor shall indemnify and save harmless SAWS, COSA and their agents and employees from all losses, damages, judgments, decrees, and expenses, liens, claims, demands, causes of action, or costs of any nature whatsoever, and/or any other liability, damage, fine or penalty (except where reimbursement for fines or penalties is prohibited by law), including all costs of



defense, attorneys fees, and settlement arising out of or in any way connected with any claims or actions at law or in equity, brought against SAWS, COSA and their agents and employees for the death or injury to persons or for damage to property caused, or allegedly caused, by any willful acts, negligence, nuisance, or breach of any term or condition of this Contract in connection with work to be performed pursuant to said Contract, by the Contractor, his agents, subcontractors, or employees. The Contractor shall furthermore indemnify and save harmless SAWS and COSA and their agents and employees from all demands of subcontractors, workmen, material men, or suppliers of machinery and parts thereof, equipment, power tools, and supplies incurred in connection with work to be performed under this Contract. Property of any description, including but not limited to property of SAWS and COSA, which shall be damaged in the performance of this Contract by the Contractor, his agents, employees, subcontractors or their employees and subcontractors shall be restored to its condition prior to damage by the Contractor at the Contractor's expense.

SUCH INDEMNITY SHALL APPLY WHERE THE CLAIMS, LOSSES, DAMAGES, CAUSES OF ACTION, SUITS, JUDGEMENTS, DECREES, OR LIABILITY ARISE IN PART FROM THE NEGLIGENCE OF SAWS OR COSA. IT IS THE EXPRESSED INTENTION OF THE CONTRACTOR, SAWS AND COSA THAT THE INDEMNITY PROVIDED FOR IN THIS PARAGRAPH IS INDEMNITY BY CONTRACTOR, TO INDEMNIFY AND PROTECT SAWS AND COSA FROM THE CONSEQUENCES OF THEIR OWN NEGLIGENCE, WHERE THE NEGLIGENCE IS A CONCURRING CAUSE OF THE INJURY, DEATH, OR DAMAGE. FURTHERMORE, THE INDEMNITY PROVIDED FOR IN THIS PARAGRAPH SHALL HAVE NO APPLICATION TO ANY CLAIM, LOSS, DEATH OR DAMAGE RESULTS FROM THE SOLE NEGLIGENCE OF SAWS AND COSA UNMIXED WITH THE FAULT OF ANY PERSON OR ENTITY. The obligations of Contractor hereunder shall survive termination of this Contract for any reason. The foregoing notwithstanding, it is agreed that with respect to any statutory restrictions affecting the validity or enforceability of the indemnification obligation herein, it shall be subject to such restrictions, and the indemnification obligation herein shall be deemed to be amended to the minimum extent necessary to conform therewith, and shall otherwise continue in full force and effect.

In any claims against SAWS or COSA or their agents or employees by Contractor, any employee of Contractor, any subcontractor, anyone directly or indirectly employed by Contractor, or any subcontractor or anyone for whose acts any of them may be liable, the indemnification obligation under this Article shall not be limited in any way by any limitation on the amount or type of damages, compensation or benefits payable by or for Contractor or any subcontractor under workers' compensation acts, disability benefit acts of other employer's benefit acts.

- 2.4 ROYALTIES AND PATENTS - The Contractor shall pay all royalties and license fees, and defend all suits or claim for infringement of any patent rights and shall indemnify and as provided under Article 2.3 save the Owner harmless from loss on account thereof, except that the Owner shall be responsible for all such royalties and license fees and loss when a particular design or process, or the product of a particular manufacturer or manufacturers is specified by Owners Contract Document; provided, however, if the Contractor has reason to believe the design, process or product specified constitutes an infringement of a patent, he shall be responsible for such royalties, license fees and loss unless he promptly gives such information to the Owner.
- 2.5 NO WAIVER OF SAWS RIGHTS - Unless specifically and unambiguously set out in the Contract Documents at the time of bid or proposal opening, no observation/inspection or approval by said Owner or any COI, officer or employee of the Owner, or any order, measurement or certificate by said Owner, or any estimate or payment by the Owner for any part of said Work, or material or method or equipment, or any extension of time, or any possession of the Work, at any time shall operate as a waiver of any provision or obligation of this Contract or any right or power herein given or reserved to said Owner, or of any right to claim any indemnity or damages for patent or latent defects in the work or otherwise as herein provided for; nor shall any Owner waiver of any Contractor breach of this Contract be deemed as a waiver of any other or subsequent Contractor breach; and every Owner right or remedy under the Contract Documents shall be cumulative, and in addition to all other Owner rights and remedies.
- 2.6 INTEREST IN SAWS CONTRACT PROHIBITED - No officer or employee of the Owner shall have a financial interest, direct or indirect, in any Contract with the SAWS, or shall be financially interested, directly, in the sale to the SAWS of any land, materials, supplies or service, except on behalf of the SAWS as an officer or employee. This prohibition extends to the City Public Service Board, City of San

Antonio, and City boards and commissions other than those, which are purely advisory.

- 2.7 EQUAL EMPLOYMENT OPPORTUNITY REQUIREMENTS/NONDISCRIMINATION CLAUSE  
The San Antonio Water System highly encourages Contractors to implement Affirmative Action practices in their employment programs. This means Contractor should not discriminate against any employee or applicant for employment because of race, color, religion, sex, pregnancy, sexual orientation, political belief or affiliation, age, disability or genetic information.
- 2.8 SMALL, MINORITY, AND WOMEN BUSINESS PROGRAM (SMWBP) REQUIREMENTS -The San Antonio Water System highly encourages contractors to form joint ventures and/or provide subcontracting opportunities to small, minority and woman-owned business (SMWB) firms. The San Antonio Water System's Good Faith Effort Plan (GFEP) is **required and must be submitted** as part of the bid package to report all small, minority, and woman-owned firm participation for this project. The GFEP must reflect all information requested as part of the total construction Contract Documents.
- 2.9 STATE SALES TAX - The Owner qualifies for exemption from state and local sales tax and will upon request by the Contractor, furnish the Contractor with a tax exemption certificate. It is the Contractor's responsibility to claim exemption from payment of applicable state and local sales taxes by complying with such procedures as may be prescribed by the State Comptroller of Public Accounts. The Contract separates the cost of materials and tangible equipment from skill, labor and other associated costs of construction. This is in accordance with the Texas Tax Code to allow tax exemption on the Contract price for materials. Certain construction equipment that is owned or rented by the CONTRACTOR may be subject to State and Local Sales Tax. The Contractor will not include in the Contract Sum or any modification thereto any amount for sales, use or similar taxes for which Owner is exempt.
- 2.10 PREVAILING WAGE RATE AND LABOR STANDARD PROVISIONS. The Provisions of Chapter 2258 of the Texas Government Code, and the "Wage and Labor Standard Provisions" amended in City of San Antonio Ordinance 2008-11-20-1045, expressly are made a part of this Contract and are incorporated herein by reference (the "PWRLSP"). In accordance therewith, a schedule of the general prevailing rate of per diem wages in this locality for each craft or type of worker needed to perform this Contract is included as part of the Bidding Document that are part of the Contract Documents. In accordance with the PWRLSP, the Contractor shall forfeit, as a penalty to Owner, sixty dollars (**\$60.00**) for each laborer, workman or mechanic employed for each calendar day, or portion thereof, in which such laborer, workman or mechanic is paid less than the stipulated prevailing wage rates for any work done under this Contract by the Contractor or any Subcontractor employed on the project. The establishment of prevailing wage rates, pursuant to Chapter 2258 of the Texas Government Code, shall not be construed to relieve Contractor from its obligation under any federal or state law, regarding the wages to be paid to or hours worked by laborers, workmen or mechanics, insofar as applicable to the work to be performed hereunder. Contractor, in the execution of this Project, agrees it shall not discriminate in its employment practices against any person because of race, color, religion, sex, pregnancy, sexual orientation, political belief or affiliation, age, disability or genetic information. Contractor agrees it will not engage in employment practices which have the effect of discriminating against employees or prospective employees because race, color, religion, sex, pregnancy, sexual orientation, political belief or affiliation, age, disability or genetic information. This Contract provision shall be included in its entirety in all Subcontractor agreement(s) entered into by the Contractor or any Subcontractor employed on the project.
- .1 LCP Tracker - Each contractor and every lower-tier subcontractor will be required to submit certified payrolls and labor compliance documentation electronically utilizing the LCP Tracker web-based application as of the first Certified Payroll Report (CPR) and with every CPR thereafter. Electronic submittal of CPRs will be accessed through a link on SAWS' "Business Center" web page. Each contractor and subcontractor will be provided a Logon identification and password to access the SAWS LCP Tracker reporting system. Electronic submittals will require data entry of weekly payroll information including: employee identification, labor classification, total hours worked and hours worked on this project, and wage and benefit rates paid. This electronic submission requirement also applies to every lower-tier subcontractor required to provide labor compliance documentation.

Additional information on the LCP Tracker System can be found on: [www.lcptracker.com](http://www.lcptracker.com).

- 2.11 ETHICS. To report suspected ethics violations impacting The San Antonio Water System, please call 1-800-687-1918.

### **ARTICLE III. CONTRACT DOCUMENTS & BONDS:**

- 3.1 PLANS AND SPECIFICATIONS - The intent of the Contract Documents is to include all items necessary for the proper execution and completion of the Work by the Contractor. The Contract Documents are complementary, and what is required by one shall be as binding as if required by all; performance by the Contractor shall be required only to the extent consistent with the Contract Documents and reasonably inferable from them as being necessary to produce the indicated and intended results. In cases of discrepancy between any drawing and the dimension figures written thereon, the dimension figures shall govern over scaled dimensions; Detailed Drawings and accompanying notations shall govern over general Drawings; Specifications shall govern over Drawings and Special Conditions shall govern over Supplemental Conditions, Specifications, Drawings and these General Conditions.

- .1 For the purposes of clarification, the most recently issued Document takes precedence over previous issues of the same document. The order of precedence for the Contract Document is as follows with the highest authority listed as "1."

1. Contract Modifications signed by Contractor and Owner.
2. Addenda, with those of later date having precedence over those of earlier date.
3. Special Conditions
4. Supplementary Conditions.
5. General Conditions
6. Specifications
7. Drawings

- 3.2 INTENT OF THE CONTRACT DOCUMENTS is to describe a functionally complete Project (or integral component part thereof) to be constructed in accordance with the Contract Documents. Any work, materials or equipment that may reasonably be inferred from the Contract Documents as being required to produce the intended result will be supplied by Contractor whether or not specifically called for by SAWS or its Consultant. When words which have a well-known technical or trade meaning are used to describe work, materials or equipment such words shall be interpreted in accordance with that meaning. Where phrases such as "directed by", "ordered by" or "to the satisfaction of", "the Consultant", "the SAWS COI" or "the Owner's Representative" occur, it is to be understood that the directions, orders, or instructions to which they relate are within the scope of, and authorized by the Contract Documents. Reference to standard specifications, manuals or codes of any technical society, organization or association, or to the Laws or Regulations of any governmental authority, whether such reference be specific or by implication, shall mean the latest standard specification, manual, code or Laws or Regulations in effect at the time of opening of Bids except as may be otherwise specifically stated in writing.

DISCREPANCY IN CONTRACT DOCUMENTS - If, during the performance of the Work, Contractor finds a conflict, error or discrepancy in the Contract Documents, Contractor shall so report to Consultant or Owner in writing immediately and before proceeding with the Work affected thereby and shall obtain a prompt written interpretation or clarification from SAWS or Consultant; however, Contractor shall not be liable to SAWS or Consultant for failure to report any conflict, error or discrepancy in the Contract Documents unless Contractor had actual knowledge thereof or should reasonably have known thereof.

- 3.3 PLANS AND SPECIFICATIONS AT THE WORK SITE - The Contractor shall maintain at the Work site at least one copy of the most recent and complete set of Contract Documents to include, but not limited to, Plans, Specifications, Addenda, approved Shop Drawings and Change Orders, in good order and marked to record all changes to the Plans and/or existing physical conditions made during construction.

- .1 RECORD DRAWINGS - Each month as the Work progresses the Consultant shall formally submit to SAWS, along with the monthly payment application, a set of red line drawings noting work completed during that period. Red Line drawings should also reflect any and all variations to the Plans and reflect all actual dimensions necessary for the development of as built drawings. As a condition precedent to any progress payment of final payment the Contractor shall have a

duty to submit, and coordinate with Consultant, Contractor's properly marked drawings. Prior to final payment to the Contractor, the Contractor who has control of the Work and is in a position to know how the Project was constructed, shall formally submit to SAWS Consultant, at the final walk through the set of clearly marked red line drawings and related documents noting work completed and any variations from the original plan and specifications for Consultant's use in preparing Owner's final "Record Drawings" for the SAWS permanent file.

- 3.4 PERFORMANCE BOND - CONTRACTOR shall furnish a Performance Bond in favor of SAWS in an amount equal to 100% of the total construction cost under this Contract. Total construction cost are defined as the entire cost of materials and their installation, and include, but are not limited to, the cost of labor, equipment, supplies, materials and additional construction costs. The Performance Bond shall: (1) guarantee the completion of the entire construction herein identified in conformity with the Plans and Specification approved by SAWS, and (2) guarantee the Work against defects in workmanship and materials for a period of twenty four (24) months after acceptance of the work by the San Antonio Water System. The bond shall be in accordance with Chapter 2253 of the Texas Government Code and Chapter 3503 of the Texas Insurance Code and shall have corporate Sureties that are licensed to conduct business in Texas. The Contractor agrees that the following shall apply to bonds provided by a Surety:

If any bond is in an amount in excess of ten (10%) percent of the Surety company's capital and surplus, the San Antonio Water System shall require, as a condition to accepting the bond, written certification that the surety company has reinsured the portion of the risk that exceeds ten (10%) percent of the surety company's capital and surplus with one or more reinsurers who are duly authorized, accredited, or trusted to do business in this state. The amount reinsured by any reinsurer may not exceed ten (10%) percent of the reinsurer's capital and surplus.

If the amount of the bond exceeds \$100,000, the surety must also:

- (1) hold a certificate of authority from the United States secretary of the treasury to qualify as a surety on obligations permitted or required under federal law; or
- (2) have obtained reinsurance for any liability in excess of \$100,000 from a reinsurer that is authorized and admitted as a reinsurer in this state and is the holder of a certificate of authority from the United States secretary of the treasury to qualify as a surety or reinsurer on obligations permitted or required under federal law.

If the Surety on any bond furnished by the Contractor to the Board is declared bankrupt or becomes insolvent, or has its right to do business revoked in the State of Texas, then the CONTRACTOR will have ten (10) days to substitute another bond and surety there for which shall be acceptable to SAWS and which shall be at the expense of the Contractor.

- 3.5 PAYMENT BOND - Contractor shall furnish Payment Bond in favor of SAWS in an amount equal to 100% of the total construction cost under this Contract. Total construction costs are defined as the entire cost of materials and their installation, and include, but are not limited to, the cost of labor, equipment, supplies, materials and additional construction costs. The Payment Bond shall be security for the payment of all persons supplying labor and material in the prosecution of the Work provided for in the Contract Documents. The Contractor agrees that the following shall apply to Bonds provided by a Surety:

If any Bond is in an amount in excess of ten (10%) percent of the Surety company's capital and surplus, the San Antonio Water System shall require, as a condition to accepting the Bond, written certification that the surety company has reinsured the portion of the risk that exceeds ten (10%) percent of the surety company's capital and surplus with one or more reinsurers who are duly authorized, accredited, or trusted to do business in this state. The amount reinsured by any reinsurer may not exceed ten (10%) percent of the reinsurer's capital and surplus.

If the amount of the bond exceeds \$100,000, the Surety must also:

- (1) hold a certificate of authority from the United States secretary of the treasury to qualify as a surety on obligations permitted or required under federal law; or
- (2) have obtained reinsurance for any liability in excess of \$100,000 from a reinsurer that is authorized and admitted as a reinsurer in this state and is the holder of a certificate of authority

from the United States secretary of the treasury to qualify as a surety or reinsurer on obligations permitted or required under federal law.

The bonds shall have corporate Sureties that are licensed to conduct business in Texas. If the Surety on any Bond furnished by the Contractor to the Board is declared bankrupt or becomes insolvent, or has its right to do business revoked in the State of Texas, then the CONTRACTOR will have ten (10) days to substitute another Bond and Surety therefore which shall be acceptable to SAWS and which shall be at the expense of the Contractor.

- 3.6 CONTRACTOR AND SURETIES STILL BOUND - No assignment, transfer or subletting, without the written consent of SAWS, and no order of SAWS for or approval of any alterations or modifications in said Specifications, Plans, or Work, and no change in the requirements or order for extra work made by the SAWS as provided in this Contract, shall ever in any manner release or diminish the responsibility of Contractor or any Surety on any bond of Contractor, but on the contrary, such responsibility shall extend to and comprehend all such changes and other matters. If any Surety upon any bond furnished in connection with the Contract becomes insolvent, or otherwise not authorized to do business in this State, the Contractor shall within ten (10) days furnish equivalent substitute forms of security while seeking substitute bonding, to protect the interests of the SAWS and of persons supplying labor or materials in the prosecution of the Work contemplated by the Contract, or may be liable for breach of Contract and default termination.
- 3.7 CONTRACTS LESS THAN \$25,000 - If the Contract Sum is less than or equal to \$25,000, Owner and Contractor may agree (at Owner's discretion) to Contractor not providing Performance and Payment Bonds; provided that in such event, no money will be paid by Owner to Contractor until Final Completion and acceptance of all Work by the Owner. If Contractor elects to provide Performance and Payment Bonds, the Contract Sum shall be payable to Contractor through progress payments in accordance with these General Conditions.

#### **ARTICLE IV. CONTRACT ADMINISTRATION:**

##### **4.1 GENERAL ADMINISTRATION**

- .1 PLANS AND SPECIFICATIONS BY CONSULTANT -The Consultant will provide general administration of the Contract during construction in accordance with the Consultant's scope of work as defined in the Consultant's Contract with the SAWS.

- .1 The Consultant has the authority to act on behalf of the Owner to the extent provided in the Construction Contract Documents. The Consultant will advise and consult with the Owner. The Owner's instruction to the Contractor may be issued through the Consultant but the Owner reserves the right to issue instructions directly to the Contractor through other designated SAWS representatives. Contractor understands that SAWS may modify the authority of such Consultant as provided in the terms of its contract relationship with the Consultant, and the Owner shall, in such event, be vested with powers formerly exercised by such Consultant, provided written notice of such modification shall be immediately served on the Contractor. Nothing herein shall authorize independent agreements between Contractor and such Consultant, nor shall the Consultant be deemed to have a legal relationship with the Contractor.
- .2 Any and all oral instructions shall be confirmed expeditiously in writing with copies furnished to the Consultant, the Owner's designated representatives, and the Contractor by the party issuing the oral instruction.
- .3 Upon the Consultant's written recommendation, the Owner's Representative shall have the final authority to reject Work performed by the Contractor which does not meet the requirements of the Contract, and to order such Work repaired, removed, or replaced in accordance with Article 5.10. Rejected Work will be documented and all payments related to the rejected Work will be suspended until the Work is accepted by the Owner.

##### **.2 PLANS AND SPECIFICATIONS BY SAWS ENGINEER**

- .1 The Engineer shall confirm all oral instructions to the Contractor expeditiously in writing.

- .2 Any other provision contained herein notwithstanding, the Engineer shall have the authority to reject Work performed by the Contractor which does not meet the requirements of the Contract, and to order such Work repaired, removed, or replaced in accordance with Article 5.10. Rejected Work will be documented and all payments related to the rejected Work will be suspended until the Work is accepted by the Owner.

#### 4.2 ACCESS TO AND OBSERVATION/INSPECTION OF THE WORK

- .1 PLANS AND SPECIFICATIONS BY CONSULTANT - The Contractor shall provide sufficient, safe, and proper facilities at all reasonable times for the observation and/or inspection of the Work by any duly authorized representative of the Owner. The Consultant and the Owner will make visits to the site at intervals appropriate to the various stages of construction to observe the progress of the executed Work and to determine if the Work is proceeding in accordance with the Contract Documents.

- .1 On the basis of such visits and on-site observations as an experienced and qualified design professional, Consultant will keep Owner informed of the progress of the Work and will guard Owner against defects and deficiencies in the Work which are the responsibility of the Contractor to prevent and/or cure.
- .2 No approval of any phase of the construction Project by any of the Owner's representatives or observer/inspectors shall relieve the Contractor from full compliance with the Contract Documents regarding the ultimate Work product. Any additional cost, damages, or delays occasioned by patent or latent defects in the Work, and/or failure to meet the requirements of the Contract Documents, at any Project phase, shall be borne by the Contractor.

- .2 PLANS AND SPECIFICATIONS BY SAWS ENGINEER - The Contractor shall provide sufficient, safe and proper facilities at all reasonable times for the observation/inspection of the Work by the duly authorized representative of the Owner. The Engineer will make visits to the site at intervals appropriate to the various stages of construction to observe the progress of the executed Work and to determine if the Work is proceeding in accordance with the Contract Documents.

- .1 No approval of any phase of the construction Project by any of the Owner's observer and/or inspectors shall relieve the Contractor from full compliance with the Contract Documents regarding the ultimate Work product. Any additional cost, damages, or delays occasioned by patent or latent defects in the Work, and/or failure to meet the requirements of the Contract Documents, at any Project phase, shall be borne by the Contractor.

- 4.3 ASSIGNMENTS AND SUBLETTING - Contractor shall not assign, transfer, convey, sublet or otherwise dispose of this Contract, or any portion thereof, or any right, title or interest in, to or under the same, without the previous written consent of the Owner. Contractor shall not assign by power of attorney or otherwise any of the monies or other considerations to become due and payable by the Owner under this Contract, without the previous written consent of the Owner. The Contractor shall notify the Owner, by written notification by certified mail to the Owner, that such assignment, transfer, conveyance or subletting, or other disposition of this Contract or any portion thereof, or any right, title or interest, in, to or under the same, is contemplated. If the Contractor does not receive written approval of such contemplated action from the Owner within thirty days of receipt of such initial request by the Contractor, such contemplated assignment, transfer, conveyance or subletting, or other disposition of this contract or any portion thereof, or any right, title or interest in, to, or under the same, shall be deemed disapproved. In no event shall the Owner be liable in excess of the consideration of this Contract in the case of any such assignment, transfer, conveyance or subletting of the Work or performance which is subject hereof.

- .1 The Owner reserves the right to withhold any monthly payment hereafter provided for in the event of an assignment or subletting of a portion of the work without the previous consent and knowledge of the Owner and by reserving such right, the Owner shall not be deemed to have waived its right to declare a full breach of this Contract for Contractor's failure to comply with provisions hereof, such remedy being alternative only and exercisable at the option of the Owner.

4.4 SUBCONTRACTORS - The Contractor shall upon executing the Contract, notify the Owner in writing of the names of all proposed first tier Subcontractors for the Work. This should include the SMWBs identified in the Good Faith Effort Plan.

- .1 SUBCONTRACTUAL RELATIONS - By an appropriate written agreement, the Contractor shall require each Subcontractor, to the extent of the Work to be performed by the Subcontractor, to be bound to the Contractor by the terms of the Contract Documents, and to assume toward the Contractor all the obligations and responsibilities which the Contractor, by these Documents, assumes toward the Owner. Said agreement shall preserve and protect the rights of the Owner under the Contract Documents with respect to the Work to be performed by the Subcontractor so that the subcontracting thereof will not prejudice such rights, and shall allow to the Subcontractor, the benefit of all rights, remedies and redress against the Contractor that the Contractor, by these Documents, has against the Owner. Where appropriate, the Contractor shall require each Subcontractor to enter into similar agreements with his Sub-subcontractors. The Contractor shall make available to each proposed Subcontractor, prior to the execution of the Subcontract, copies of the Contract Documents to which the Subcontractor will be bound by this paragraph and identify to the Subcontractor any terms and conditions of the proposed Subcontract which may be at variance with the Contract Documents. Each Subcontractor shall similarly make copies of such Documents available to his Sub-subcontractor.

4.5 SEPARATE CONTRACTS

- .1 The Owner reserves the right to let other Contracts in connection with this Work. The Contractor shall afford other Contractors reasonable opportunity for the introduction and storage of their materials and the execution of their work and shall properly connect and coordinate his Work with their work.
- .2 When separate Contracts are awarded for different portions of the Project, "the Contractor" in the Contract Documents in each case shall be the Contractor who executes each separate Contract. This Contractor shall properly connect and coordinate his Work with the work of other Contractors. If any part of this Contractor's Work depends for proper execution or proper results on the work of any other separate Contractor, this Contractor shall inspect and promptly report in writing to the Consultant and SAWS COI any discrepancies or defects he may find in the work of any separate Contractor that render it unsuitable to achieve proper connection, execution and results. Failure of this Contractor to so inspect and report obvious discrepancies or defects shall constitute an acceptance of the other Contractor's work as fit and proper to receive this Contractor's Work, except as to defects which may develop in the other separate contractor's work after the execution of this Contractor's work.
- .3 Any other provision contained herein notwithstanding, should this Contractor negligently cause damage to the work or property of any separate Contractor on the Project, this Contractor shall, upon due notice, endeavor to settle with such other Contractor by agreement. A reciprocal clause shall be placed in the Contract Documents between the SAWS and the separate Contractor if involving other SAWS work. If such separate Contractor sues the SAWS and/or its agents on account of any damage alleged to have been so sustained, the SAWS and/or its agents shall notify this Contractor who shall defend the SAWS and/or its agents' interests and Contractor's own interests in such proceedings and pay all attorney fees, and costs in connection therewith, and if any judgment against the SAWS results there from, this Contractor shall pay or satisfy that judgment.

4.6 CONTRACT TERMINATION

- .1 TERMINATION BY CONTRACTOR - If the Work is stopped by SAWS for a period of ninety (90) consecutive days under an order of any court or other public authority having jurisdiction, or as a result of an act of a higher governmental authority, such as a declaration of a national emergency making materials unavailable, through no act or fault of the Contractor or a Subcontractor or their agents or employees or any other persons performing any of the Work under a Contract with the Contractor, then the Contractor may upon ten (10) additional days written notice after first providing a complete and detailed written explanation of the event that constitutes an allowable termination under this provision to SAWS and the Consultant, at which

time SAWS will promptly provide a written determination whether in its sole discretion the event detailed by the Contractor constitutes an acceptable Contract termination event, pursuant to this provision; then the Contractor may terminate the Contract and recover from the Owner payment for all Work performed as of the date that Contractor gives written notice of termination pursuant to this paragraph. Owner shall not be liable for the payment of any lost or anticipated profit on Work not performed or for any consequential damages on termination of this Contract. If the Work is recommenced during the ten (10) day notice period, the Contractor may not terminate the Contract.

- .2 TERMINATION BY OWNER - If the Contractor is adjudged as bankrupt, or if he makes a general assignment for the benefit of his creditors, without the consent of the SAWS or if a receiver is appointed on account of his insolvency, or if he persistently or repeatedly refuses or fails, except in cases for which extension of time is provided, to supply enough properly skilled workmen or proper materials, or persistently disregards laws, ordinances, rules, regulations or orders of any public authority having jurisdiction pertaining to the Work, or otherwise is guilty of a substantial violation of a provision of the Contract Documents warranting Owner default of Contractor, then the Owner may, without prejudice to any right or remedy and after giving the Contractor and Contractor's Surety, if any, ten (10) days written notice, terminate the employment of the Contractor and/or take possession of the site and of all materials, and may upon order of a court of competent jurisdiction take possession of equipment, tools, construction equipment and machinery thereon owned by the Contractor. Should the Surety fail to pursue completion of the Work with reasonable speed, the Owner may arrange for completion of the Work and deduct the cost thereof from the unpaid Contract sum remaining, including the cost of additional Owner administration and Consultant services made necessary by such default or neglect, in which event no further payment shall then be made by the Owner until all Cost of completing the Work shall have been paid. If the unpaid balance of the Contract sum exceeds all the costs of finishing the Work, including direct and indirect consequential costs, attorney's fees and compensation for the Consultant's additional services made necessary thereby, such excess sum shall be paid to the Contractor. If such costs exceed the unpaid balance, the Contractor or his surety shall pay the difference to the Owner. This obligation for payment shall survive the termination of the Contract
- .1 TERMINATION FOR CONVENIENCE - The right to terminate this Contract for the convenience of Owner (including, but not limited to, non-appropriation of funding) expressly is retained by Owner. In the event of a termination for convenience by Owner, Owner shall, at least ten (10) calendar days in advance, deliver written notice of the termination for convenience to Contractor. Upon Contractor's receipt of such written notice, Contractor immediately shall cease the performance of the Work and shall take reasonable and appropriate action to secure and protect the Work then in place. Contractor shall then be paid by Owner, in accordance with the terms and provisions of the Contract Documents, an amount not to exceed the actual labor costs incurred, the actual cost of all materials installed and the actual cost of all materials stored at the Project site or away from the Project site, as approved in writing by Owner but not yet paid for and which cannot be returned, and actual, reasonable and documented demobilization costs, if any, paid by Contractor and approved by Owner in connection with the Work in place which is completed as of the date of termination by Owner and that is in conformance with the Contract Documents, less all amounts previously paid for the Work. No amount ever shall be owed or paid to Contractor for lost or anticipated profits on any part of the Work not performed or for consequential damages of any kind.
- .2 In the event that Owner shall be prevented from completing performance of its obligations under this Contract by an act of God or other occurrence whatsoever which is beyond the control of Owner, then Owner shall be excused from any further performance of its obligation and undertakings.
- .3 Contractor may not recover from Owner any lost or anticipated profit on Work not performed or consequential damages of any kind on or for termination of this Contract by Owner or Contractor or for any breach of this Contract by Owner.



#### 4.7 CONTRACTOR BID SUSPENSION POLICY

- .1 INTRODUCTION - SAWS through its Board of Trustees routinely contracts with private businesses to build, maintain and repair SAWS structures, vehicles, equipment, property and other assets. SAWS desires to receive quality service and performance at a fair price for each construction services, material, supply, and equipment Contract awarded under Section V of SAWS Purchasing and Contracting Policy.

On occasion, SAWS finds that the quality of service or performance required by the Contract Documents is not provided. Therefore SAWS requires a policy and a process to address nonperformance by contractors and, if necessary, to suspend certain contractors from further contract awards for a period of time.

The purpose of this policy is to establish a procedural framework to suspend a contractor from consideration for award of future Contracts with SAWS, based on a determination that the Contractor has not met the performance standards as outlined in Article 4.7.4, Reasons for Contractor Suspension.

Staff will implement procedures consistent with this Article 4.7 to address service quality and performance issues. These procedures will include adequate safeguards, reviews and appeals to insure that Contractors being considered for suspension are provided ample opportunity for discussion, communication, and corrective actions prior to being suspended.

The term "Contractor" as used in this Article herein means a construction Contractor, subcontractor, vendor, supplier, materialman and any other person or entity supplying labor and/or material to SAWS on a contract basis.

"SAWS Management Officials" means SAWS personnel who are at the Manager level or above and who are involved in the supervision, review or acceptance of services, work or materials provided by Contractors under Contract with SAWS.

Any provision contained herein notwithstanding, SAWS reserves the right to not award a Contract to any Contractor who SAWS determines has failed to perform work to the quality of satisfaction required by SAWS and is therefore not a responsible bidder. In cases where SAWS determines that a Contractor is not a responsible bidder on a Contract due to Contractor's failure to provide quality and satisfactory work, SAWS will first give notice to the Contractor, prior to making the ultimate determination as to Contractor being a non-responsive bidder, of the reasons for SAWS determination. The Contractor will then have an opportunity to respond to SAWS determination. At that time SAWS shall in its sole discretion make a final determination, as to whether Contractor is a responsible bidder on a given Contract.

- .2 CREATION OF CONTRACTING COMMITTEE - There shall be a standing Contracting Committee comprised of SAWS staff appointed by the President/Chief Executive Officer of SAWS. At least one Committee member will be a Vice President of SAWS and all other Committee members will be Managers or higher. The members of the Committee hearing the complaint will be SAWS Management Officials not directly involved with the Contractor being considered for bid suspension. If a standing Contracting Committee member has been involved in the day-to-day administration or supervision of a Contract with a Contractor being reviewed by the Committee, such Committee member will not serve on the Committee with regard to a complaint or appeal affecting that Contractor. The President/CEO may either appoint a substitute or the Committee may proceed with fewer members, but in no event will there be less than three members available at any Committee meeting to hear information presented.
- .3 ADMINISTRATIVE PROCEDURES - Subject to applicable laws, regulations and this policy, SAWS legal department will develop the Administrative and Operational Procedures for Contractor Bid Suspension Hearings and Appeals as outlined in "**Exhibit B**" of these General Conditions. The Contracting Committee may recommend changes to the Administrative and Operational Procedures. Changes to the Administrative and Operational Procedures must be approved by the President/CEO.

.4 REASONS FOR CONTRACTOR SUSPENSION:

The Contracting Committee may suspend a Contractor for any of the following reasons:

- .1 Contractor's failure to satisfy Contract obligations;
- .2 Contractor's unsatisfactory safety performance;
- .3 Contractor's failure to meet schedules or deadlines established in a Contract with SAWS;
- .4 Contractor's failure to meet specifications or plan requirements;
- .5 Contractor's failure to staff a project as specified in Contract Documents;
- .6 Contractor's provision of inaccurate information in bid documents;
- .7 Contractor's failure to provide change order documentation specified in Contract Documents;
- .8 Contractor's failure to comply with warranty obligations;
- .9 Contractor's failure to satisfy all Contract obligations to subcontractors, material men and laborers on SAWS projects as specified in Contract Documents;
- .10 Contractor's failure to correct valid customer or public complaints as provided for in the Contract specifications, city ordinance, or applicable law;
- .11 Conviction of a principal, owner, manager or corporate officer of the Contractor of a criminal offense;
- .12 Relevant documented information from other parties with whom a contractor has contracted which are negative in nature and reflective of any of the foregoing reasons.

.5 COMPLAINT AND HEARING PROCEDURES - A SAWS Management Official may submit a complaint to the Chief Operating Officer recommending that a particular Contractor be suspended from consideration for award of Contracts with SAWS. The Chief Operating Officer will determine whether the complaint is in accordance with the Administrative and Operating Procedures. Upon such a determination, the Chief Operating Officer will convene the Contracting Committee in a Hearing on Contractor Bid Suspension. The standing Contracting Committee will consider all relevant information and decide whether the Contractor will be suspended from bidding on SAWS Contracts.

.6 NOTICE OF SUSPENSION BY CONTRACTING COMMITTEE - If the Contracting Committee decides to suspend the Contractor, the Chief Operating Officer will send written notice as described in Article 4.7 Contractor Bid Suspension Policy. This notice will be sent by certified mail, return receipt requested.

.7 SUSPENSION PERIOD - If the Contractor has not been previously suspended pursuant to this policy, the term of the suspension will be for one (1) year from the date of issuance of the notice of suspension.

If the Contractor has been previously suspended pursuant to this policy, the term of the suspension will be for two (2) years from the date of issuance of the notice of suspension.

.8 APPEALS PROCESS - The Contractor may request review of the decision by the President/Chief Executive Officer of SAWS by filing a written request for review with the President/CEO within ten (10) days of the date of the notice of the result of the appeal hearing. The suspension will stay in effect throughout the appeal process.

.9 SEVERABILITY - Should any section, part, paragraph, sentence, phrase, clause or word of this policy, for any reason, be held illegal, inoperative or invalid, or if any exception to or limitation

upon any general provision herein contained be held to be unconstitutional or invalid or ineffective, the remainder shall, nevertheless, stand effective and valid as if it had been enacted without the portion held to be unconstitutional or invalid or ineffective.

- .10 ADMINISTRATIVE LIABILITY - No officer, attorney, agent or employee of SAWS renders himself or herself personally liable for any damage that may accrue to persons or property as a result of any act required or permitted and performed in good faith in the discharge of his or her duties under this policy so long as such officer, attorney, agent or employee is acting within the scope of his or her official capacity. Any suit brought against an officer, attorney, agent or employee of SAWS acting within his or her official capacity and scope, as a result of any act required or permitted and performed in good faith in the discharge of duties under this policy, will be defended by SAWS legal counsel until the final determination of the proceeding therein.

#### 4.8 SUSPENSION OF WORK BY OWNER

- .1 The Owner may suspend said Work either partially or totally by his written order whenever in his opinion the interests of SAWS require the suspension of such Work. In the event that the Owner suspends Project Work, the Contractor hereby acknowledges and agrees that so long as the total suspension(s) is (are) for a period not to exceed ten (10) cumulative days accruing throughout the entire Contract Time, that the Contractor is not entitled to request a negotiated adjustment of the Contract Sum nor an extension of the Contract Time. Such right to suspend Project Work for periods not to exceed ten (10) cumulative days accruing throughout the entire Contract Time without compensation to the Contractor, is expressly reserved by SAWS.
- .2 Any total suspension of Project Work by the Owner that extends beyond ten (10) cumulative days accrued throughout the entire Contract Time, may entitle the Contractor to request either a negotiated adjustment of Contract Sum or an extension of Contract Time, or both, as directly attributable to such extended total suspension of Project Work, Provided:
  - .1 Any equitable extension of the Contract Time shall not exceed the actual delay caused by the temporary suspension, as determined by Owner, and Engineer and or Consultant;
  - .2 Any equitable adjustment to the Contract Sum shall be for the actual, necessary and reasonable costs of properly protecting any Work finished or partially finished during the period of the temporary suspension; provided, however, that no payment of profit and/or overhead shall be allowed on top of these costs; and
  - .3 If it becomes necessary to move equipment from the Project and then return it to the Project when the Work is ordered to be resumed, an equitable adjustment to the Contract Sum for the actual, necessary and reasonable cost of these moves; provided, however, that no adjustment to the Contract Sum shall be due if said equipment is moved to another Project of Owner.
- .3 Any partial suspension of the Work by the Owner that extends beyond the mutually determined point in time when the ten (10) cumulative days accruing throughout the entire Contract Time, are effectively exceeded, may entitle the Contractor to request either a negotiated adjustment of Contract Sum or an extension of Contract Time, or both, as directly attributable to such extended partial suspension of Project Work.
  - .1 In the event that the Owner partially suspends the Work in such a manner that some work is able to continue, the Contractor and SAWS hereby agree to discuss the impact of the partial suspensions upon dependent Contract Work, and to mutually determine when the ten (10) cumulative days accruing throughout the entire Contract Time and expressly reserved by the SAWS without compensation to the Contractor, would effectively be exceeded.
  - .2 The SAWS COI shall have the right to stop the Work whenever such stoppage may be necessary to ensure proper execution of the Contract. Such temporary stoppage shall be followed by a Written Order as outlined in Article 4.8.1

- .4 The Owner and the SAWS COI shall at any time during the Contract Time have the right to suspend or stop the Work under Article 4.8.1 or Article 4.8.3.2 when the SAWS COI or any other authorized representative of the Owner reasonably believes that there exists any dangerous condition, nuisance or safety risk to workers, the general public or property on the site or on property adjacent thereto or otherwise violates a term or condition of the Contract Documents. Notwithstanding the foregoing provisions of Article 4.8, the Contractor shall not be entitled to any adjustment of the Contract Sum or extension of the Contract Time relating to any suspension of the Work by the Owner or the SAWS COI for any reasons under this Article 4.8.4. and the Owner shall have no other liability of any kind to the Contractor with respect to any suspension of the Work for reasons under this Article 4.8.4.
- .5 The Owner and the SAWS COI shall at any time during the Contract Time have the right to suspend or stop the Work under Article 4.8.1 or Article 4.8.3.2 when the SAWS COI or any other authorized representative of the Owner reasonably believes that there exists on the site any environmental condition which could reasonably be expected to result in any liability, costs or expense to the Owner or the Contractor arising under any laws, statutes, ordinances, rules and regulations of any governmental, quasi-governmental or regulatory authority which include but are not limited to the transportation, storage, placement, handling, treatment, discharge, generation, production, removal, or disposal (collectively, "Treatment") of any waste, petroleum product (including without limitation, gasoline and diesel fuel), waste products, or any other substance, the Treatment of which is regulated by any Laws (collectively, "Waste"), or any other environmental condition that would cause the Work to be in violation of any laws, statutes, ordinances, rules and regulations ("Laws") of any governmental, quasi-governmental or regulatory authority . Notwithstanding the foregoing provisions of Article 4.8, the Contractor shall not be entitled to any adjustment of the Contract Sum or extension of the Contract Time relating to any suspension of the Work by the Owner or the SAWS COI for environmental reasons under this Article 4.8.5., and the Owner shall have no other liability of any kind to the Contractor with respect to any suspension of the Work for environmental reasons under this Article 4.8.5. At all times during the performance of the work by the Contractor under this Contract, the Contractor will comply with all Laws. The Contractor agrees to (a) give notice to the owner immediately upon Contractor's acquiring knowledge of the existence of any Waste or other environmental condition on the site with a full description thereof, (b) promptly comply with any Laws applicable to the Contractor or the site requiring the removal, treatment or disposal of such Waste or proper treatment of the environmental condition as required by Law and provide Owner with satisfactory evidence with such compliance and (c) provide Owner within thirty (30) days after demand by Owner with a bond, letter of credit or similar financial assurance evidencing to the Owner's satisfaction that adequate funds are available to pay the costs of removing, treating and disposing of such Waste or proper treatment of the environmental condition as required by Law.
- 4.9 PROTECTION OF PRIVATE PROPERTY - The SAWS has secured right-of-way and easements, as shown on the plans, to be occupied by the finished construction, with only such additional temporary construction easements as shown for use by the Contractor in carrying out his Work. The Contractor shall take proper measures to protect all property within all construction easements, and adjacent or adjoining property which might be injured by any process of construction; and, in case of any injury or damage, he shall restore at his own expense the damaged property to a condition equal to or better than that existing before such injury or damage was done, or he shall make good such injury or damage in a manner acceptable to the owner and/or private or public owner.
- .1 The Contractor shall immediately correct customer complaints for such items as, but not limited to, driveway access, mailboxes, privacy fences, public safety hazards, public nuisances, water and sewer services as directed by the SAWS COI.
- .2 The Contractor shall not, except upon procuring written consent from proper private parties, enter or occupy with men, tools, materials, or equipment, any privately owned land except for those on easements provided herein by SAWS. Contractor must submit a copy of the easement agreement to SAWS.
- .3 No permit shall be removed outside the permanent easement, except where expressly authorized in writing by the Owner and City of San Antonio. Any tree not authorized for removal shall be adequately protected against damage from construction operations. Contractor shall be

responsible for any damage, destruction or other harm including but not limited to all costs, fees, or other expenses attributable thereto, caused to trees not authorized for removal that is due to or arise out of Contractor's Work at the Project.

**ARTICLE V. CONTRACT RESPONSIBILITIES:**

- 5.1 OWNER-CONTRACTOR OBLIGATIONS - The Owner and the Contractor each binds himself, his partners, successors, assigns and legal representatives to the other party hereto and to the partners, successors, assigns and legal representatives of such other party in respect to all covenants, agreements and obligations contained in the Contract Documents. The Contractor shall not assign the Contract or sublet it as a whole without the prior written consent of the Owner, nor shall the Contractor assign any monies due or to become due to him hereunder, without the prior written consent of the Owner and in the manner established in Article 4.3 herein.
- 5.2 OWNER'S RESPONSIBILITY - Projects Contracted through other outside entities and containing utility work by SAWS shall be managed by the other entity with support by SAWS personnel. Contractor shall report directly to the other entity. Utility projects contracted through SAWS, which contain secondary street work, shall be managed by SAWS with support by other entity personnel. Contractor shall report directly to SAWS.
- .1 The design of this Project was performed by a professionally licensed Engineer who is an authorized representative of the Owner, who will exercise the authority and functions of the Owner as the project Consultant in the following respects:
- .1 Provide Contractor with benchmarks.
  - .2 Checking of shop drawings furnished by the Contractor in compliance with Article 5.12 herein.
  - .3 Consultation and advice during construction and rendering those decisions requiring interpretation of the Plans and Specifications.
  - .4 Make visits to the Site at intervals appropriate to the various stages of construction operations to become generally familiar with and to keep the Owner informed about the progress and quality of the portion of the Work completed, and to endeavor to guard the Owner against defects and the Work.
  - .5 Assist in the Substantial Completion inspection.
  - .6 Assist in the final inspection.
  - .7 Assist in the preparation of the monthly and final quantity and pay estimates.
  - .8 Any terms and conditions of the consultant's Contract with the Owner shall be cumulative of the above.
- .2 Unless otherwise provided or ordered, all resident observation and inspection on all SAWS contracted projects will be performed by the SAWS COI, who will exercise the authority and functions of the Owner in the following respects:
- .1 Review laboratory, mill and shop tests of materials and equipment for general compliance with the Plans and Specifications.
  - .2 Observation and inspection of the authorized Work, and administration for the Owner, and review of all Work performed for general compliance with the Plans and Specifications.
  - .3 Stop the Work or any portion of the Work if Contractor fails to carry out the Work in accordance with the Contract, or fails to correct Work which is not in accordance with requirements of the Contract. However, the right of the SAWS to stop the Work as provided for in Article 4.8, will not give rise to a Claim for delay or to a duty on the part

of the SAWS to exercise this right for the benefit of Contractor or any other person or entity. SAWS will provide the Contractor with a written explanation and detail for the stoppage of work.

- .4 Review monthly and final quantity and pay estimates.
  - .5 Conduct substantial completion observation and inspection.
  - .6 Conduct final observation and inspection.
  - .7 Determine acceptability of the finally completed Work.
- .3 Quality Assurance Random sampling and testing of materials, inspection of laboratory testing processes and procedures for Quality Assurance purposes beyond those required to be performed at the expense of the Contractor under their Quality Control program in full compliance with 5.3 herein, may be performed by SAWS, at the expense of SAWS, in a certified commercial testing laboratory approved and designated by SAWS. The Contractor at their expense shall furnish assistance in obtaining and providing samples for SAWS Quality Assurance purposes.

### 5.3 CONTRACTOR'S RESPONSIBILITIES

- .1 Quality Control - The Contractor agrees and understands that the Contractor is responsible for performing Quality Control inspection and testing services to assure Project compliance with Contract Documents. Sampling and testing of materials, laboratory inspection of materials and processes for quality control purposes shall be performed at the expense of the Contractor or Supplier by an independent commercial laboratory approved by the SAWS COI. All test reports and shop drawings shall be signed and sealed by a Texas Registered Professional Engineer and submitted to the SAWS COI. All structural members shall be marked or stamped individually with an identifying number for the purpose of cross-referencing all reports. All test reports and vendors' certifications for materials incorporated into the project shall be submitted in accordance to the latest revision of the International Building Code, as required by City Building Permit, with sufficient time in advance as to allow the Owner, Owner's representative, Consultant, Owner's Third Party Inspection Agency and City Building Officials to review and approve materials, installation and placement prior to next stage of the project. Approval does not constitute or relieve the Contractor's obligation under this contract to fully comply with the specifications and building permit requirements.
- .2 The Contractor shall supervise and direct the Work using the best skill and attention. Any provision contained herein notwithstanding, the Contractor shall be solely responsible for all construction means, methods, techniques, sequences and procedures, and for the implementation of safety precautions and for coordinating all portions of the Work under this Contract.
- .3 The Contractor shall give the SAWS COI reasonable advanced notice of the readiness of any Work for observation/inspection, and when practicable, twenty-four (24) hours notice. If any underground Work is performed without the proper prior notification to the COI, it shall be uncovered for observation/inspection and properly restored at the Contractor's expense.
- .4 If the Contractor, in the course of the Work, finds any discrepancies between the Plans and the physical conditions of the locality, or any errors or omissions in the Plans or the layout as given by survey points and instructions, he shall immediately inform the SAWS COI and Consultant, with a RFI, and the Consultant and/or Engineer shall promptly investigate the same. Any Work impacted by the discrepancy performed by Contractor after such discovery, until authorized, will be done at the Contractor's risk and/or expense.
- .5 Contractor's Risk and Inventory - Contractor shall be responsible for the complete, timely, performance of the Work under this Contract and compliance with the Contract Documents. Contractor shall be responsible for the safe storage and inventory control of all materials paid by SAWS as "materials on site", on the project site and/or within off site bonded/insured storage facilities either owned or leased by the Contractor. Contractor shall allow full access, seven days a week, 24 hours, to storage facilities, whether on site or off site, as requested by SAWS COI. Contractor shall protect materials and Work from all theft, loss, vandalism, or damage from any

cause whatsoever until final Project completion by Contractor and acceptance by Owner; and shall deliver said Work and improvements to the SAWS in a completed and acceptable condition in accordance with the Contract Documents.

- .6 It is the intention of the SAWS to be sensitive to the needs and concerns of the citizenry. It is the Contractor's responsibility to adhere to this policy to the best of his ability. The Contractor, subcontractor and his employees should, whenever possible, address citizen inquiries about the project, provide names and numbers of SAWS personnel, relay citizen complaints, and provide continuous access to the citizen's property.
- .7 Permits - Unless otherwise provided in the Contract Documents, Contractor shall obtain and pay for all construction permits, including review fees, inspections, and licenses. Owner shall reasonably assist Contractor, when necessary, in obtaining such permits and licenses. Contractor shall pay any and all charges, fees and costs necessary for obtaining permits for the prosecution of the Work. The contractor shall be responsible for all costs associated with registering with the City of San Antonio Right of Way Office (COSA ROW), applying and obtaining COSA ROW Street cut permit(s) as required for the project and shall keep the permit active during the course of the work. Contractor is also responsible for the initial permit, permit renewals, expedited permits and any and all costs inclusive of but not limited to COSA ROW inspection fees, penalties and/or any and all fees associated with the permit. To register the contractor should contact the COSA ROW office at 210-207-6949.
- .8 Project Sign – Each Project Specification will contain a detailed requirement for Project signage that identifies the site and Work to general citizenry.
- .9 Pre-Construction and Post-Construction Videos – The Contractor shall provide pre-construction videos prior to commencement of the project in accordance with standard specification for construction Item No. 1114, Pre-Construction Videos. The video shall identify the condition of all existing surface features within the project limits. The Contractor shall submit two copies of the completed video prior to request for mobilization. The Contractor shall also submit two copies of the completed post-construction video of all surface features within the project limits within ten (10) days following the date of substantial completion.
- .10 Large Water Main Shut Downs: Projects that include a Large Water Main (16-inches and larger), will require advance coordination from the Contractor with Owner, with a minimum of two weeks' notice to Owner prior to the desired shut down date. The Contractor is to have all material and equipment on site and have the necessary prep work done in order to minimize the shutdown period required for the tie in Work. Mains Larger than 16-inches that will be required to be shutdown throughout the year may (as solely determined by Owner) require a temporary water main, valves and other appurtenances to keep the water main in service. The size of the temporary water main will be determined by Owner and shown on the plans by the Consultant or as Directed by Owner.
- .11 Water and Sewer Service to Customers – the Contractor shall maintain uninterrupted service to SAWS customers at all times.
- .12 Contractor will abide by all applicable policies and regulations of Owner with respect to conduct, including smoking, parking of vehicles, security regulations and entry to adjacent facilities owned by the Owner.
- .13 Independent Contractor - In performing the Work under this Contract, the relationship between Owner and Contractor is that of an independent Contractor. Contractor shall exercise independent judgment in performing the Work and solely is responsible for setting working hours, scheduling and/or prioritizing the Work flow and determining the means and methods of performing the Work, subject only to the requirements of the Contract Documents. No term or provision of this Contract shall be construed as making Contractor an agent, servant or employee of Owner or making Contractor or any of Contractor's employees, agents or servants eligible for the fringe benefits, such as retirement, insurance and worker's compensation which Owner provides to its employees.

- 5.4 SUPERINTENDENT - The Contractor shall keep on-site for the Project during its progress a competent Superintendent, able to communicate fluently in English, and any necessary assistants, all satisfactory to the Owner. A Superintendent shall be identified in writing to the Owner at the pre-construction meeting. The Superintendent shall represent the Contractor and all directions given to the Superintendent shall be binding on the Contractor. Oral directions from the SAWS representatives involving critical situations or Work elements shall be immediately (as may be reasonable under the circumstances and in accordance with the Contract Documents), confirmed in writing by Owner to the Contractor. The Contractor's Superintendent shall provide full-time on-site supervision to any Work ongoing at the site by its own forces or subcontractors, using the best industry skill and attention. The Contractor's Superintendent shall not be replaced without first providing written notice to the Owner. The written notice provided to the Owner shall contain the credentials for their proposed replacement Superintendent. The Owner will review the credentials supplied and if in the Owners discretion they are appropriate for the work, approve the proposed replacement Superintendent. The Superintendent may not be employed on any other project prior to Final Completion of the Work, without the approval of the Owner, which approval will not be unreasonably withheld.
- 5.5 INCIDENTAL WORK, CONNECTIONS AND PASSAGEWAYS - The Contractor shall perform all incidental Work necessary to complete this Contract, including, but not by way of limitation, the following: Contractor shall make and provide all suitable reconnections with existing improvements as are necessarily incidental to the proper completion of the Project; Contractor shall provide passageways or leave open such thoroughfares in the Work area as may be reasonably required by SAWS and shall protect and guard same at Contractor's own risk, and shall continuously maintain the Work area in a clean, safe and workmanlike manner.
- 5.6 CONDITIONS AT SITE
- .1 Contractor declares that prior to the submission of the Bid Proposal on this Contract, the Contractor has thoroughly examined the location(s) of the Work to be performed, has become familiar through their own investigation with any and all conditions, including but not limited to typical local geophysical conditions at or near this Project, and has read and has thoroughly understood the "Contract Documents" and any other document made available prior to the bid opening, as they may relate to the physical conditions prevalent or likely to be encountered in the performance of the Work at such location(s). Any testing, boring, soil profiles and water elevations shown on Contract Documents, or otherwise provided, were obtained solely for the use of SAWS in the preparations of its plans and the Contractor is cautioned, and SAWS MAKES NO WARRANTY OR REPRESENTATION, AS REGARDING THE ACCURACY OF SUCH DATA AND THE CONTRACTOR SHOULD MAKE NO RELIANCE THEREON IN DETERMINING CONTRACTOR'S MEANS AND METHODS OF CONSTRUCTION. Contractor, by the performance of the above, hereby generally acknowledges that such "Contract Documents" are not obviously deficient and will enable the Contractor to accomplish the proper performance of the Work at the Project site.
  - .2 The Contractor shall immediately, and before such discovered conditions and/or structures are disturbed, notify the Owner with a RFI of (1) subsurface or latent physical and/or structural conditions at the site differing materially from those indicated in the Plans, Specifications, and other Contract Documents or (2) newly discovered, unknown physical conditions at the site of an unusual nature differing materially from those geophysical conditions typically encountered in the type Work being performed and generally being recognized as not indigenous to the Texas environs and are not indicative of otherwise disclaimed in the plans, Specifications, and Contract Documents. The Owner, or designated representative, shall promptly investigate the reported physical and/or structural conditions, and shall determine whether or not the physical and/or structural conditions do materially so differ and whether they cause an increase or decrease in the Contractor's cost of, and/or the time required for performance of any part of the Work under this Contract. In the event that the Owner in its reasonable determination finds that the physical and/or structural conditions do materially so differ from the provisions of the Contract Documents, a negotiated, equitable, adjustment may be made to either the Contract Time or Contract Sum, or both as in the Owner's determination is reasonable, and a Contract Change Order shall be issued in writing accordingly.



- .1 No claim of the Contractor under this Article shall be allowed unless the Contractor has given the written notice called for above, prior to disturbing the discovered conditions and/or structures.
- .2 Any other provision contained herein notwithstanding, no claim by the Contractor for an equitable adjustment to the Contract Time or Contract Sum, or both, shall be allowed if claimed by the Contractor after Final Payment as defined in Article 7.3 herein has been made by the SAWS to the Contractor under the terms of this Contract.

5.7 CONTRACTOR'S STANDARD COMMERCIAL INSURANCE SPECIFICATIONS AND CERTIFICATE OF LIABILITY INSURANCE REQUIREMENTS

.1 Commercial Insurance Specifications ("Insurance Specifications"):

.1 Commencing on the date of this Contract, the Contractor shall, at his own expense, purchase, maintain and keep in force such lines of insurance coverage as will protect him and the San Antonio Water System ("SAWS") and the City of San Antonio ("the City") and their employees and agents from claims, which may arise out of or result from his operations under this Contract, whether such operations are by himself, by any sub-contractor, supplier or by anyone directly or indirectly employed by any of them or by anyone for whose acts any of them may be liable, including, without limitation, the following lines of insurance coverage:

- .1 Workers' Compensation (WC) insurance that will protect the Contractor, SAWS and the City from claims under statutory Workers' Compensation laws, disability laws or such other employee benefit laws and that will fulfill the requirements of the jurisdiction in which the work is to be performed.

This line of insurance coverage shall be endorsed to provide a Waiver of Subrogation in favor of SAWS and the City of San Antonio with respect to both this insurance coverage and the Employers' Liability (EL) insurance (as specified immediately below in Article 1.1.2).

- .2 Employers' Liability (EL) insurance (Part 2 under the standard Workers' Compensation insurance policy) that will protect the Contractor, SAWS and the City for damages because of bodily injury, sickness, disease of vendor's employees apart from that imposed by Workers' Compensation laws.

The EL line of insurance coverage shall have minimum policy limits of liability of not less than:

\$1,000,000.00 Bodily Injury by Accident  
 \$1,000,000.00 Bodily Injury by Disease - Each Employee  
 \$1,000,000.00 Bodily Injury by Disease - Policy Limit

- .3 Commercial General Liability (CGL) insurance that will protect the Contractor, SAWS and the City from claims for damages because of bodily injury, personal injury, sickness, disease or death and insurance that will protect the Contractor, SAWS and the City from claims for damages to or destruction of tangible property of others, including loss of use thereof.

This line of insurance coverage shall:

- Cover independent Contractors;
- Not include any exclusions relating to blasting, explosion, collapse of buildings or damage to underground property;
- The GENERAL AGGREGATE limit shall apply per Project;

- Afford coverage for Products Liability and/or Completed Operations and, Contractual Liability.

The minimum policy limits of liability for this line of insurance coverage shall be:

\$1,000,000.00 Occurrence Limit  
 \$2,000,000.00 General Aggregate  
 \$2,000,000.00 Products/Completed Operations Aggregate  
 \$1,000,000.00 Personal and Advertising Injury  
 \$1,000,000.00 Contractual Liability

This line of insurance coverage shall be endorsed:

- Additional Insured - The Commercial General Liability policy shall be endorsed naming the SAWS and the City of San Antonio as an Additional Insured for both ongoing and completed operations, and
- Waiver of Subrogation - The Commercial General Liability policy shall be endorsed with the Waiver of Subrogation in favor of SAWS and the City of San Antonio.

OR

- .4 Owner and Contractor Protective Liability (OCP) Insurance policy which insures SAWS and the CITY and their agents and employees with the same coverage specified in Article 5.7.1.1.3 above unless the CGL policy specified in Article 5.7.1.1.3 above includes the Endorsement CG2503 - per project general aggregate limit applies.
- .5 Commercial/Business Automobile Liability (AL) insurance that will protect the Contractor, SAWS and the City from claims for damages arising out of the maintenance, operation, or use of any owned, non-owned or hired vehicles.

Minimum policy limits of liability for this line of insurance coverage for bodily injury and property damage combined shall be not less than \$1,000,000.00 per each occurrence.

This line of insurance coverage shall be endorsed:

- Additional Insured - The Commercial/Business Automobile Liability policy shall be endorsed naming the SAWS and the City of San Antonio as an Additional Insured; and
  - Waiver of Subrogation - The Commercial/Business Automobile Liability policy shall be endorsed with the Waiver of Subrogation in favor of SAWS and the City of San Antonio.
- .6 Excess/Umbrella Liability (UL) insurance shall have minimum policy limits of \$2,000,000 per occurrence and \$2,000,000 in the aggregate. This policy shall be of an "Occurrence" type and the limit of liability shall be concurrent with (following form) and in excess of the EL, CGL, and AL lines of insurance coverage as described in Articles 5.7.1.1.2, 5.7.1.1.3, and 5.7.1.1.5 listed above.

NOTE - For the Excess/Umbrella Liability policy, describe in the Description of Operations section of the Certificate of Liability Insurance ("Certificate"), the coverage form under which this line of coverage is written – either:

- Umbrella liability form; or

- Excess Liability form.

This line of insurance coverage shall be endorsed:

- Additional Insured - The Commercial General Liability policy shall be endorsed naming the SAWS and the City of San Antonio as an Additional Insured for both ongoing and completed operations.
- Waiver of Subrogation - The Commercial General Liability policy shall be endorsed with the Waiver of Subrogation in favor of SAWS and the City of San Antonio.

- .7 Contractor's Pollution Liability Insurance with limits of \$2,000,000 per claim/occurrence/\$2,000,000 in the aggregate.

The policy shall provide either a "claims made" or an "occurrence based" coverage for all claims, liabilities, damages, costs, fees, and expenses of any kind or character arising out of any Pollution Condition(s) (as defined below) that is in any way related to Contractor's operations, actions or inactions, and completed operations associated with any work performed by Contractor, its subcontractors, or any of their respective employees, agents, representatives, or officers under this Contract.

If the Policy is "claims made" based, coverage must be maintained for a minimum of twenty-four (24) months after the date that a Conditional Letter of Acceptance is issued, or if the Contract is terminated for any reason, for a minimum of twenty-four (24) months following the date of termination.

The "claims made" policy retroactive date will be no later than the Contract effective date or the project commencement date, whichever is earliest.

If the Policy is "occurrence based", no policy retroactive date is required and, the twenty-four (24) months extension of coverage after the date that a Certificate of Completion is issued, or if the Contract is terminated for any reason, is not required.

Any exceptions to the above cited coverage forms must be reviewed and approved by SAWS Risk Manager.

Pollution Condition(s) means the discharge, dispersal, release or escape of any solid, liquid, gaseous or thermal irritant or contaminant, including, but not limited to, smoke, sewage, vapors, soot, fumes, acids, alkalis, toxic chemicals, medical waste and waste materials into or upon land, the atmosphere or any watercourse or body of water, including groundwater, provided such conditions are not naturally present in the environment in the amounts or concentrations discovered.

The Contractor's Pollution Liability Insurance will pay on behalf of the Contractor, SAWS and the City all claims, demands, damages, liabilities, costs, fees, and expenses of any kind or character for bodily injury or death, property damage, environmental or natural resource damage, and any fines, fees, assessments or penalties of any kind assessed by any governmental department, agency or commission that result from or are related to a Pollution Condition(s). Coverage will include all subcontractors hired by Contractor to perform any work on the Project or under this Contract.

The policy shall also include the following coverage provisions:

- .1 Provide for bodily injury to include physical injury, sickness, disease, mental anguish and emotional distress sustained by any person, including death;

- .2 All costs that are related to or that arise out of or from the investigation or adjustment of any claim or in connection with any court, arbitration, mediation, state administrative hearing, or other proceeding of any kind, including attorneys fees, expert witness fees, costs, charges and expenses of any kind or character, that arise out of or that are related to a Pollution Condition(s);
- .3 Coverage shall be Primary and in addition to any other valid and collectible insurance carried by SAWS and the CITY as respects to this Contract;
- .4 Coverage for Natural Resource Damages and any fines, fees penalties or assessments by any governmental agency, commission or department related to any Pollution Condition(s);
- .5 Insured versus Insured exclusion, if found in the policy, shall not apply to a claim by an Insured who qualifies as a Client of the Named Insured under the policy;
- .6 If Non-Owned Disposal sites are used for disposal of wastes, these sites shall be specifically included under the Contractors Pollution Liability Insurance policy; and
- .7 Coverage for punitive, exemplary, and multiple damages.

Commercial/Business Automobile Liability policy of the CONTRACTOR hauling excavated spoil shall either be endorsed to provide coverage under the CA-9948 endorsement or the Contractor's Pollution Liability Insurance policy shall be endorsed to provide transportation coverage beyond the boundaries of the job site.

NOTE - For the Contractor's Pollution Liability, declare on the Certificate of Liability Insurance ("Certificate") the coverage form under which this line of insurance is written – either:

- Claims-made form - if the coverage form declared on the Certificate is the Claims-made form, also include on the Certificate the "Retroactive-date" when this line of coverage was first written or started, or the Contract date or the project commencement date, whichever is earliest; or
- Occurrence based form – no additional wording required.

- .8 All Risk Builders' Risk (*if applicable*) - In the event, the project contracted for herein requires the building of structures or facilities used for storage, housing equipment or the occupancy of personnel, the Contractor shall provide Physical Damage Insurance on Builder's Risk Form which insures SAWS and the City for damages to all Property Purchased for, or Assigned to, the Project commencing on the start date through completion. Policy limits shall be in an amount equal to the total construction cost contracted herewith. The policy form shall be an All Risk Builders' Risk form and shall include the flood and earthquake endorsements.
- .2 Contractor shall require all Sub-contractors to carry lines of insurance coverage appropriate to their Scope of Work performed.
  - .3 Contractor agrees that with respect to the above required lines of insurance, all insurance policies are to contain or be endorsed to the extent, not inconsistent with the requirements of the issuing insurance carrier, to provide for an endorsement that the "other insurance" clause shall not apply where SAWS and the City are an Additional Insured shown on the policy if such endorsement is permitted by law and regulations.

- .4 Contractor shall, upon request of SAWS, provide copies of all insurance policies and endorsements required under Contract.
- .5 Contractor is responsible for the deductibles under all lines of insurance coverage required by these Insurance Specifications.
- .6 The stated policy limits of each line of insurance coverage required by these Specifications are MINIMUM ONLY and it shall be the Contractor's responsibility to determine what policy limits are adequate and the length of time each line of insurance coverage shall be maintained; insurance policy limits are not a limit of the Contractor's liability.
- .7 These minimum limits required of each line of insurance coverage may be either basic policy limits of the WC, EL, CGL and AL or any combination of basic limits or umbrella (Umbrella liability form) or excess (Excess Liability form) limits. SAWS acceptance of Certificate(s) that in any respect, do not comply with these Insurance Specifications, does not release the Contractor from compliance herewith.
- .8 Each line of insurance coverage that is required under these Insurance Specifications shall be so written so as to provide SAWS and the City thirty (30) calendar days advance written notice directly of any suspension, cancellation or non-renewal or material change in coverage, and not less than ten (10) calendar days advance written notice for nonpayment of premium.
- .9 Within five (5) calendar days of a suspension, cancellation or non-renewal of any required line of insurance coverage, the Contractor shall provide SAWS a replacement Certificate with all applicable endorsements included. SAWS shall have the option to suspend the Contractor's performance should there be a lapse in coverage at any time during this Contract.
- .10 Failure to provide and to maintain the required lines of insurance coverage shall constitute a material breach of this Contract.
- .11 In addition to any other remedies, SAWS may have, upon the Contractor's failure to provide and maintain any insurance or policy endorsements to the extent and within the time herein required, SAWS shall have the right to order the Contractor to stop performing services hereunder and/or withhold any payment(s) which become due to the Contractor hereunder until the Contractor demonstrates compliance with the Insurance Specifications hereof.
- .12 Nothing herein contained shall be construed as limiting, in any way, the extent to which the Contractor may be held responsible for payments for damages to persons or property resulting from the Contractor 's or its sub-contractors' performance of the services covered under this Contract.
- .13 It is agreed that the Contractor's insurance shall be deemed primary and non-contributory with respect to any insurance or self insurance carried by SAWS, the City and their employees and agents for liability arising out of operations under this Contract.
- .14 Contractor agrees that all lines of insurance coverage required by these Insurance Specifications shall be with insurance companies, firms or entities that have an A.M. Best rating of "A- ("A"- minus)" and a Financial Size Category of a "VII" or better. All lines of insurance coverage shall be of an "Occurrence" type except for the Contractor's Pollution Liability line of insurance coverage.

SAWS will accept worker's compensation insurance coverage written by the Texas Workers Compensation Insurance Fund.

- .15 SAWS reserves the right to review the above stated Insurance Specifications during the effective period of this Contract and any extension or renewal hereof and to request modification of lines of insurance coverage and their respective liability limits when deemed necessary and prudent by SAWS' Risk Manager and Legal Department based upon changes

in statutory law, court decisions, or circumstances surrounding this Contract.

In no instance will SAWS and the City allow modification whereupon SAWS and the City may incur increased risk exposure.

.2 Certificate(s) of Liability Insurance (“Certificate”) Requirements

Prior to the commencement of any Services under this Contract and once notified by SAWS Contracting Official that your Company has been selected as the apparent successful Contractor pursuant to a competitive bid selection process, pending Board final approval, and, a request is made for you to submit your Company’s Certificate of Liability Insurance, that Certificate must meet all of the following requirements:

- .1 The Contractor shall have completed by its insurance agent(s), and submitted to SAWS Contracting Department within 5 business days, a Certificate(s) of Liability Insurance (“Certificate(s)”) providing evidence of the lines of insurance coverage pursuant to Articles 5.7.1.1 through 5.7.1.5 above.
- .2 The original Certificate(s) or form must include the agent's original signature, including the signer's company affiliation, mailing address, Office and FAX phone numbers, email address, and contact person’s name; and, be mailed, with copies of all applicable endorsements, directly from the insurer's authorized representative in strictly compliance with Articles 5.7.2.1.6 (Certificate Holder) and Articles 5.7.2.1.7 (Distribution of Completed Certificates) below.
- .3 SAWS will not accept Memorandum of Insurance or Binders as proof of insurance.
- .4 SAWS shall have no duty to pay or perform under this construction Contract until such certificate(s) and applicable endorsements have been received, reviewed and deemed 100% compliant with the CONTRACTOR’S STANDARD COMMERCIAL INSURANCE SPECIFICATIONS AND CERTIFICATE OF LIABILITY INSURANCE REQUIREMENTS as contained in the Bid Document by SAWS’ Risk Management/Contract Services Department. No one other than SAWS Risk Manager shall have authority to waive any part of these requirements.
- .5 The SAWS Project/Contract number(s) along with its Project Name must be included in the Description of Operations section located in the bottom half of the standard ACORD Certificate forms.
- .6 Certificate Holder - SAWS shall be shown as the Certificate Holder in the Certificate Holder section located in the bottom half of the standard ACORD Certificate forms and formatted as follows:

San Antonio Water System  
c/o Ebix BPO  
PO Box 100085-ZD  
Ref. # (SAWS Contract/Project #)\*  
Duluth, GA 30096

*\*SAWS Contracting Official will include in the above address, the correct, complete Ref# in the written confirmation of your selection as a CONTRACTOR pending final Board approval.*

**DO NOT BEGIN THE DISTRIBUTION OF ANY CERTIFICATE(S) BEFORE RECEIVING AND INSERTING THE COMPLETE REFERENCE NUMBER INTO THE CERTIFICATE HOLDER ADDRESS SHOWN ABOVE.**

- .7 Distribution of Completed Certificates - Completed Certificates shall be distributed by the Contractor as follows:

.1 Send Original:

.1 By Mail:

San Antonio Water System  
C/O Ebix BPO  
P.O. Box 100085-ZD  
Ref. # (SAWS Contract/Project #)  
Duluth, GA 30096

.2 By Fax: 1-770-325-6502

.3 By E-Mail: [saws@ebix.com](mailto:saws@ebix.com)

.2 Send Copy to:

San Antonio Water System  
Attention: Contract Administration  
P.O. Box 2449  
San Antonio, TX 78298-2449

.8 Contractor shall be responsible for obtaining Certificates of Insurance from the first tier Sub-contractor, and upon request furnish copies to SAWS.

.3 SURVIVAL

Any and all representations, conditions and warranties made by Contractor under this Contract including, without limitation, the provisions of Articles 5.7.1.1.2, 5.7.1.1.3 and 5.7.1.1.4 of these COMMERCIAL INSURANCE SPECIFICATIONS AND CERTIFICATES OF LIABILITY INSURANCE REQUIREMENTS are of the essence of this Contract and shall survive the execution and delivery of it, and all statements contained in any document required by SAWS whether delivered at the time of the execution, or at a later date, shall constitute representations and warranties hereunder.

5.8 MATERIALS & WORKMANSHIP

- .1 MATERIALS - Unless otherwise specified, all materials incorporated in the permanent Work shall be new, and both workmanship and materials shall be of good quality in accordance with Specifications. The Contractor shall, if required, furnish satisfactory evidence as to the supply or manufacture, and quality of materials supplied. All materials that come in direct or indirect contact with potable water must conform to ANSI/NSF Standard 60 for direct additives and ANSI/NSF 61 for indirect additives and must be in full compliance with all current regulations of the TCEQ and any other applicable regulatory requirements.
- .2 USE OF MATERIALS WITHIN THE RIGHT-OF-WAY - The Contractor, with the approval of the SAWS COI, may use in the Work any suitable stone, gravel, or sand found in the excavation that otherwise meets or exceeds Contract Specifications. The Contractor shall not over excavate any material from within the right-of-way, which is not within the excavation limits as required under the plans and specifications. Any over excavation will be at the contractor expense. No recycled concrete shall be used.
- .3 SALVAGEABLE MATERIAL - Salvageable material, as stated by the Contract documents, shall remain the property of the Owner and shall be relocated and stored at the job site by the Contractor unless the Contract Document provide for storage elsewhere.
- .4 DISPOSAL OF NON-HAZARDOUS WASTE MATERIAL/SUBSTANCES - The Contractor shall be responsible for disposing of all Non-Hazardous Material as the term is defined in Article I herein including old concrete or any other non-hazardous material which is required to be removed from the project. Such material shall not be deposited in any sanitary sewer, creek, river, watercourse or MS4, (unless a written exception is approved by Owner) as the term is defined herein.

- .5 **DISPOSAL OF HAZARDOUS MATERIAL/SUBSTANCES** - The Contractor shall be responsible for disposing of all hazardous materials/substances, as that term is defined in Article I herein in accordance with all applicable Federal, State and local laws, rules, regulations or ordinances, and in accordance with any specific instructions set out in the Plans and Specification herein.
- .6 **RECLAMATION OF LOW AREAS** - The Contractor may undertake the reclamation of low areas with the prior approval of the Owner.
- .7 **BLOCKAGE OF THE MS4** - The Contractor shall comply with the provisions of the appropriate City Ordinances. In no event shall the Contractor block any portion of the MS4 with fill. Should any blockage occur the Contractor shall remove such fill, at contractor's expense, as directed by the SAWS COI.
- 5.9 **TESTING** - The Owner or the Consultant may require special inspection, testing or approval of material or Work for determining compliance with the requirements of the Contract Documents. Upon Owner-authorized direction of the Consultant, the Contractor shall promptly arrange for such special testing, inspection or approval procedure. Should the material or Work fail to comply with the requirements of the Contract Documents, the Contractor shall bear all costs of the special testing, inspection or approval as well as the cost of replacement of any unsatisfactory material or Work as provided by Article 5.10, otherwise, should the Work prove not defective, the Owner shall bear such costs and an appropriate Change Order shall be issued.
- 5.10 **REMOVAL OF DEFECTIVE WORK** - If any materials furnished under this Contract fails to perform in the manner such material is expected to perform in accordance with intended usage, the Contractor shall proceed to remove from the Project at his sole expense all such materials, whether worked or unworked, and to remove all portions of the condemned Work.
- 5.11 **EQUAL MATERIALS** - It is not the intent of the Specifications to unreasonably limit materials to the product of any particular manufacturer or supplier. Where definite materials, equipment and/or fixtures have been specified by name, manufacturer or catalog number, it has been done so as to set a definite standard and/or a reference for comparison as to quality, application, physical conformity, and other characteristics. It is not the intention to discriminate against or prevent any dealer, jobber or manufacturer from furnishing materials, equipment, and/or fixtures that meet or exceed the characteristics of the specified items. Unless otherwise provided for in the Specifications, Contractor's substitution of materials, equipment and/or fixtures shall not be made without prior written approval from the Consultant, and the Owner Request for substitutions will not be accepted from anyone except the Contractor, and such requests will not be accepted (if appropriate) until after the Contract has been awarded.
- 5.12 **SHOP DRAWINGS, PRODUCT DATA AND SAMPLES**
- .1 Shop Drawings, Product Data, Samples and similar submittals are not part of the Contract. The purpose of their submittal is to demonstrate, for those portions of the Work for which submittals are required by the Contract Documents, the way by which the Contractor proposes to conform to the information given and the design concept expressed in the Contract Documents.
- .2 The Contractor shall review for compliance with the Contract Documents, approve and submit to the Engineer/Consultant Shop Drawings, Product Data, Samples and similar submittals required by the Contract Documents in such sequence as to cause no delay in the Work or in the activities of the Owner or of separate contractors. Submittals which are not marked as reviewed for compliance with the Contract Documents and approved by the Contractor will be returned by the Engineer/Consultant without action. Contractor shall submit to Engineer/Consultant for review and approval or for other appropriate action, five (5) hard copies and/or electronic copies, if requested by COI, of all Shop Drawings, Product Data, Samples or similar submittals bearing a stamp or specific written indication that Contractor has satisfied the Contractor's responsibilities under the Contract Documents with respect to his review of his submission. All Shop Drawings, Product Data, Samples and similar submittals in regards to Pipeline Projects shall be provided to the Engineer/Consultant during pre-construction meeting.



- .1 By approving and submitting Shop Drawings, Product Data, Samples and similar Submittals, the Contractor represents that the Contractor has determined and verified materials, quantities, specified performance criteria, installation requirements, catalog numbers, field measurements and filed construction criteria related thereto, or will do so, and has checked and coordinated the information contained within such submittals with the requirements of the Work and of the Contract Documents.
- .2 Contractor shall give Engineer/Consultant specific written notice of each variation that the Shop Drawings, Product Data, Samples and similar submittals may have from the requirements of the Contract Documents, and, in addition, shall cause a specific Contractor notation to be made on each Shop Drawing, Product Data, Sample and similar submittals submitted to Consultant for review, approval, or other appropriate action highlighting each such variation.
- .3 The Contractor shall perform no portion of the Work for which the Contract Documents require submittal and review of Shop Drawings, Product Data, Samples or similar submittals until the respective submittal has been approved by the Engineer/Consultant. The Engineer/Consultant will review and return such submittals within twenty (20) calendar days or within a reasonable period so as to not delay the project.
- .4 Engineer/Consultant's review, approval, or other appropriate action regarding Contractor's submissions will be only to check conformity with the design concept of the Project and for compliance with the information contained in the Contract Documents and shall not extend to means, methods, techniques, sequences or procedures of construction (except where a specific means, method, technique, sequence or procedure of construction is indicated in or required by the Contract Documents) or to safety precautions or programs incident thereto. The review and approval of a separate component item will not indicate approval of the assembly into which the item is functionally integrated. Contractor shall make corrections required by Engineer/Consultant, and shall return the required number of corrected copies of Shop Drawings, Product Data, Samples or similar submittals to the Contractor. Contractor may be required to resubmit as required revised Shop Drawings, Product Data, Samples or similar submittals for further review and approval. Contractor shall direct specific attention in writing to any new revisions not specified by Contractor on previous Contractor submissions.
- .3 The Work shall be in accordance with approved submittals, except that the Contractor shall not be relieved of responsibility for deviations from requirements of the Contract Documents by the Engineer/Consultant's approval of Shop Drawings, Product Data, Samples or similar submittals unless the Contractor has specifically informed the Engineer/Consultant in writing of such deviation at the time of submittal and (1) the Engineer/Consultant has given written approval regarding the specific deviation as a minor change in the Work, or (2) a Change Order or Field Work Directive has been issued authorizing the deviation. The Contractor shall not be relieved of responsibility for errors or omissions in Shop Drawings, Product Data, Samples or similar submittals by the Engineer/Consultant's approval thereof.
- .4 Where Engineer/Consultant requires by written request an approved Contractor Shop Drawing, Product Data, Sample, or similar submittals any related Work performed by Contractor prior to Consultant's review and approval of the affected submission will be at the sole risk of Contractor.
- .5 The Contractor shall not be required to provide professional services which constitute the practice of architecture or Engineering unless such services are specifically required by the Contract Documents for a portion of the Work or unless the Contractor needs to provide such services in order to carry out the Contractor's responsibilities for construction means, methods, techniques, sequences and procedures. The Contractor shall not be required to provide professional services in violation of applicable law. If professional design services or certifications by a design professional related to systems, materials, or equipment are specifically required of the Contractor by the Contract Documents, the Owner and the Engineer/Consultant will specify all performance and design criteria that such services must satisfy. The Contractor shall cause such services or certifications to be provided by a properly licensed design professional, whose signature and seal

shall appear on all drawings, calculations, specifications, certifications, Shop Drawings and other submittals prepared by such professional. Shop Drawings and other submittals related to the Work designed or certified by such professional, if prepared by others, shall bear such professional's written approval when submitted to the Engineer/Consultant. The Owner and the Engineer/Consultant shall be entitled to rely upon the adequacy, accuracy and completeness of the services, certifications or approvals performed by such design professionals, provided the Owner and Engineer/Consultant have specified to the Contractor all performance and design criteria that such services must satisfy. The Engineer/Consultant will review, approve or take other appropriate action on submittals only for the limited purpose of checking of conformance with information given and the design concept expressed in the Contract Documents.

### 5.13 CONTRACTOR'S WORK PROGRESS SCHEDULE

- .1 The "Work Progress Schedule" and successive updates or revisions thereof are for the Contractor's use in managing the Work. The Work Progress Schedule is for the information of the Owner and to demonstrate that the Contractor has complied with requirements for planning the Work. The Owner's acceptance of a schedule and schedule updates or revisions constitutes the Owner's agreement to coordinate its own activities with the Contractor's activities as shown on the schedule. The Contractor shall provide a Work Progress Schedule to the Owner within ten (10) calendar days after receipt of the Authorization to Proceed.
  - .1 Acceptance of the Work Progress Schedule, or update and/or revision thereto, does not indicate any approval of the Contractor's proposed sequences and duration.
  - .2 Acceptance of a Work Progress Schedule update or revision indicating early or late completion does not constitute the Owner's consent to any changes, alter the terms of the Contract, waive either the Contractor's responsibility for timely completion, or waive the Owner's right to damages for the Contractor's failure to do so.
- .2 The Contractor's scheduled dates for completion of any activity or of the entire Work do not constitute a change in terms of the Contract. Change Orders are the only method of modifying the completion date(s) and Contract Times.
- .3 Submittal of a schedule, schedule revision or schedule update constitutes the Contractor's representation to the Owner, as of the date of the submittal; of the accurate depiction of all progress to date and that the Contractor will follow the schedule as submitted in performing the Work.
- .4 The Contractor shall provide a Work Progress Schedule to the Owner within ten (10) calendar days after receipt of the Authorization to Proceed. The schedule shall show the order in which the Contractor proposes to carry out the Work and the anticipated start and completion dates of each phase of the Work.
- .5 The Work Progress Schedule must indicate the times (number of days or dates) for starting and completing the various stages of the Work, including any Milestones specified in the Contract Documents or "Hold Points" designated by the Owner during the review process, identify the "Critical Path" for completing the Work, identify when all Subcontractors will be utilized, and take into consideration any limitations on Working Hours. This Work Progress Schedule, a copy of which shall be made available at the job site(s), must contain sufficient detail to indicate that the Contractor has properly identified required Work elements and tasks, has provided for a sufficient and proper workforce and integration of Subcontractors, has provided sufficient resources and has considered the proper sequencing of the Work required to result in a successful Project that can be completed within the Contract time. Contractor's submitted Work schedule shall be in a detailed, precedence-style critical path management Microsoft Project or Primavera format, satisfactory to the Owner and the Engineer/Consultant.
- .6 Schedule Updates - The Work Progress Schedule and the Submittal Schedule shall be updated monthly, as a minimum, to reflect progress to date and current plans for completing the Work. A paper and an electronic copy of the update shall be submitted to the Engineer/Consultant as directed. The Owner has no duty to make progress payments unless accompanied by the updated

Work Progress Schedule. The anticipated date of Substantial Completion shall show all extensions of time granted through Change Order(s) as of the date of the update. The Contractor, after coordination and consultation with the Owner, may revise the Work Progress Schedule logic only with the Owner's concurrence, which will not be unreasonably withheld, when, in the Contractor's judgment, it becomes necessary for the management of the Work. The Contractor shall identify all proposed changes to schedule logic to Owner and to the Engineer/Consultant via an Executive Summary accompanying the updated schedule for review prior to implementation of any revisions. If the Contractor's operations are materially affected by changes in the Plans or in the amount of Work, or if he has failed to comply with the anticipated progress, the Contractor shall submit a revised schedule reflecting the change in progress, within five (5) calendar days of the occurrence of such event. The schedule may also be revised by the Contractor in response to the reasonable request of the Owner.

- .1 Each schedule shall segregate the Work into a sufficient number of activities to facilitate the efficient use of critical path method scheduling by the Contractor, Owner, and Engineer/Consultant. Each schedule activity shall be assigned a cost value consistent with the Schedule of Values so as to allow the Owner and Contractor to project cash flow for the Project.
- .2 Each schedule shall include activities representing manufacturing, fabrication, or ordering lead time for materials, equipment, or other items for which the Engineer/Consultant is required to review submittals, shop drawings, product data, or samples.
- .3 Each schedule, other than the initial schedule, shall indicate the activities, or portions thereof, which have been completed; shall reflect the actual time for completion of such activities; and shall reflect any changes to the sequence or planned duration of all activities.
- .4 If any updated schedule exceeds the time limits set forth in the Contract Documents for Substantial Completion of the Work, the Contractor shall include with the updated schedule a statement of the reasons for the anticipated delay in Substantial Completion of the Work and the Contractor's planned course of action for completing the Work within the time limits set forth in the Contract Documents. If the Contractor asserts that the failure of the Owner or the Engineer/Consultant to provide information to the Contractor is the reason for anticipated delay in completion, the Contractor shall also specify what information is required from the Owner or Engineer/Consultant.
- .5 Neither the Owner nor the Contractor shall have exclusive ownership of float time in the schedule, and all float time (if any) shall inure to the benefit of the project. The Contractor agrees to use its best efforts not to sequence the Work or assign activity duration so as to produce a schedule in which more than one-fourth of the remaining activities have no float time.
- .7 Submission of any schedule under this Contract constitutes a representation by the Contractor that as of the date of the submittal: (1) the schedule represents the sequence in which the Contractor intends to prosecute the remaining Work; (2) the schedule represents the actual sequence and duration used to prosecute the completed Work; (3) that to the best of its knowledge and belief the Contractor is able to complete the remaining Work in the sequence and time indicated; and, (4) that the Contractor intends to complete the remaining work in the sequence and time indicated.
- .8 The Contractor shall submit in conjunction with his monthly request for payment, a copy of the current adjusted Work Progress Schedule showing the progress of the Work to date. If it is determined by Owner that the Contractor is not maintaining his anticipated progress, then the Owner may withhold approval of the monthly progress payment as provided in Article 7.2.

#### 5.14 SEQUENCE OF CONSTRUCTION

- .1 PHASES OF CONSTRUCTION - The Contractor shall perform the Work as provided in the "Special Conditions" or as shown on the Contract Documents. The Contractor may submit to Owner a revised Contractor Phasing Plan prior to start of construction for review and approval by the Owner. If the Owner determines that the revised Contractor's Phasing Plan is not acceptable

as being in the best interest of the Owner, then the Contractor shall proceed with the Work in accordance with the Owner's Phasing Plan at no additional cost to the Owner.

- .2 DETOUR ROUTES - A detour route for through traffic (the means and methods of which as to be determined by the Contractor) must be provided by the contractor where the proposed construction is located within the limits of a street designated as "Collector", "Secondary" or Primary". The detour route must be approved by the ROW owner, such approval to be obtained by Contractor prior to construction. The Contractor shall not begin construction of the Project or close any streets until adequate barricades, detour signs and electronic message boards (if needed) have been provided, erected and maintained in accordance with the detour route and details shown on the Plans or as shown on the approved traffic control plan. The Contractor shall notify the SAWS COI forty-eight (48) hours in advance of closing any street to through traffic. Local traffic shall be permitted the use of streets under construction where feasible.

5.15 CONSTRUCTION STAKES - The Contractor shall hire a licensed surveyor, at his expense, for field staking and any other surveying requirements pertinent to the project.

5.16 PUBLIC UTILITIES

.1 Owner's Responsibility:

1. The Owner shall cause to be sent a set of Plans to utilities listed on the plans. The Owner shall request that the utilities review such Plans and Specifications to determine and/or verify the location of any utilities within the project site. The utility shall further be requested to communicate in writing the results of such review to the Contractor.

.2 Contractor's Responsibility:

- .1 The Contractor is hereby required to become familiar with all the existing utility structures, lines and mains that are known to exist and may be encountered within and/or adjacent to the limits of the work covered by the Contract. While the existence and location of underground utilities indicated on the Plans are taken from the most current utility records available to the Consultant and/or Engineer, the Contractor understands and acknowledges that the notation of such underground utilities on the Plans does not constitute a warranty, representation or guarantee by the Owner or Consultant regarding those Underground Facilities. In addition, Contractor further understands and acknowledges that Owner and Consultant are under no obligation to indicate the location of any private service lines on the Plans.
- .2 The Contractor shall go to the Project site, locate, and verify depth of any utilities indicated on the Plans prior to the Commencement of Work. The Contractor shall further investigate the possible location of any private service lines prior to the Commencement of Work as defined under Article 8. To facilitate this obligation on the part of Contractor, the Contractor shall communicate with the utilities listed on the plans, call for locations and subsequently visit the project site with a qualified utility representative of each utility listed on the plans, prior to the Commencement of Work. The information resulting from such on-site investigations shall govern over the information notated on the Plans, when and if a conflict between such information arises. In the event such investigations on the part of Contractor result in a utility location adjustment, Contractor shall not commence work until the completion of such adjustment has been completed.
- .3 The Contractor acknowledges and agrees that maintaining continuity of utility service to utility customers is critical, including but not limited to the need for temporary water services.
- .4 The Contractor shall be responsible for protecting the integrity of all utilities (public or private) either shown on the Plans or discovered during the Contractor investigations required in Article 5.16.2.2 herein. Such method of protection shall first be reviewed and approved by the affected utility.
- .5 The Contractor shall be responsible for any damages to any utilities (public or private)

either shown on the Plans or discovered during Contractor investigations acquired in Article 5.16.2.2 herein. Any existing utilities shown on the plans or discovered during Contractor investigations set out herein which cannot be relocated shall be protected by the Contractor as part of the original Bid Proposal Price submitted by Contractor. The Contractor shall pay for temporary relocation of utilities for the Contractor's convenience.

- .6 Contractor shall be responsible for damage to utilities not shown on the Plans and not discovered during Contractor's investigations required in Article 5.16.2.2 herein when the existence of such a utility or the suspected existence of such a utility should have been anticipated and investigated by the Contractor, based upon certain physical manifestations observed during the course of construction or other tangible evidence which constitutes common knowledge in the construction industry of the probable existence of a utility. A Contractor shall not be responsible for damages to utilities not shown on the Plans and not discovered during Contractor's investigation required herein when in accordance with the common knowledge in the construction industry; the existence of such utility could not reasonably be anticipated.
  - .3 Temporary clearance of high voltage (600 volts and above) and overhead electrical lines is required prior to the operation of equipment within 10 feet of such lines (Texas Health and Safety Code, sections 752.003 and 752.006). The Contractor shall bear the expense to obtain the necessary temporary clearance from the high voltage line operator or utility company. Temporary clearance shall be a temporary barrier separating and preventing contact of material, equipment, persons, communications with high voltage electrical lines, or temporary de-energization and grounding or temporary relocation, or raising of the lines; as approved by the utility company.
  - .4 In the case of sewer, water, gas, electric, telephone, cablevision cable, or any other utility shown on the Plans and/or discovered during the Contractor's investigations required in Article 5.16.2.2 herein, the Contractor will use care in excavating over, under and around such lines and will provide all necessary temporary bridging during construction so as to maintain continuous service of the utility line. The Contractor shall backfill around the main and complete his construction operations in such a manner as to leave the utility line firmly and securely bedded in its original position without damage to any protective coatings.
  - .5 In instances where gas or water mains are exposed during construction, the utility company owning or operating the service shall be given at least a twenty-four (24) hour notice by the Contractor prior to backfilling in order that the protective coating on the mains may be inspected and/or repaired by utility company.
  - .6 BRACING AND SUPPORTING - In areas where utilities are known to be near the Project site, and could be damaged by soil movement, slips or cave-ins, the Contractor shall take all precautions necessary to protect such utilities from damage and shall pay for the repair of any such damages caused by Contractor's failure to properly protect the utility.
- 5.17 **SUBSURFACE CONDITIONS** - Reports of explorations and tests of subsurface conditions at the construction site, where applicable, may be available for review. These reports if available were procured by SAWS in order to generally forecast soil conditions at various depths to assist the Consultant in designing the Project. The logs and descriptive data are **NOT PART OF THE CONTRACT DOCUMENTS** but are made available for the general information of bidders and SAWS SPECIFICALLY DISCLAIMS ANY AND ALL WARRANTY (INCLUDING WITHOUT LIMITATION AND IMPLIED WARRANTIES OF MERCHANTABILITY) OR GUARANTEE AS TO SUITABILITY OF FITNESS OF THE REPORTS, DATA OR INFORMATION FOR ANY PARTICULAR PURPOSE and neither the SAWS nor the Consultant assumes any obligation or responsibility, either specific or implied, for the accuracy or completeness of any information contained therein. Sub-surface conditions along and across the Project site may vary significantly from those shown on the test reports. All excavations shall be unclassified (as provided in the specifications) and shall include all materials encountered regardless of their nature or the manner in which they are removed.

- 5.18 WORKING HOURS - No Work, with the exception of such items as curing of concrete, maintenance of barricades, etc., will be allowed by the Owner between the hours of 5:00 p.m. and 8:00 a.m. of the following day, unless directed by Owner or requested in writing by Contractor and approved by Owner and the ROW Owner. In addition to no work being permitted on Sundays or holidays, no work shall occur on Saturdays without specific, written permission of the Owner's representative forty-eight (48) hours in advance of intent to perform Work.
- 5.19 USE OF STREETS RIGHT OF WAY - The Contractor shall confine the movements of all steel tracked equipment to the limits of the Project and any such equipment will not be allowed to use City, Public or Private streets unless being transported on pneumatic tired vehicles. Any damage to existing City streets caused by the Contractor's equipment shall be repaired by Contractor at his own expense upon direction, and in the manner prescribed by City's or other appropriate entities specifications and the SAWS COI.
- 5.20 DAMAGES TO STREETS caused by the Contractor, within the limits of the Project but not within the current phase being constructed, shall be repaired by the Contractor at his own expense upon direction by the SAWS COI.
- 5.21 DUST CONTROL - The Contractor will apply appropriate amounts of water (or other appropriate substance), to the area under construction and on detours as required to maintain sufficient moisture content in the surface layer for dust control.
- 5.22 SANITARY PROVISIONS - The Contractor shall provide and maintain in a neat, sanitary condition, rest room facilities for the use of his employees and authorized on-site visitors as may be necessary to comply with the requirements and regulations of the City Health Department and of the State Department of Health.
- 5.23 USE OF EXPLOSIVES - the use of explosives of any kind for this project is strictly prohibited.
- 5.24 WATER - the responsibility shall be upon the Contractor to provide and maintain an adequate supply of water for construction and on-site domestic consumption. Any connections and piping that the Contractor deems necessary for providing and maintaining an adequate water supply to the jobsite shall be installed at his expense and at locations approved by the SAWS COI. A fire hydrant meter is required. Before final Project acceptance, all temporary connections and piping installed by the Contractor in accordance with this paragraph shall be removed in a manner satisfactory to the SAWS COI.
- 5.25 ELECTRICITY - All electric current required by the Contractor at the jobsite shall be procured by Contractor. All necessary meters, switches, connections and wiring shall be installed at locations approved by the SAWS COI. Before final acceptance, all meters, switches, connections and wiring installed by the Contractor pursuant to this paragraph shall be removed in a manner satisfactory to the SAWS COI.
- 5.26 CLEANING
- .1 The Contractor shall at all times keep the Project premises safe and free from accumulation of waste materials or rubbish caused by the Work under this Contract. This includes the maintenance of grass, shrubbery, and trees within the ROW.
  - .2 Upon completion of the Work, and prior to the Owner's final inspection, the Contractor shall present the premises in a neat and clean condition, prepared for acceptance by Owner.
  - .3 Prior to final acceptance of the Work, Contractor shall reasonably restore the Project site to its pre-project condition (accounting for such restoration concerns as cosmetic appearance, landscaping, drainage gradients, accessibility, etc.) to the extent permitted by the Project improvements. All of this incidental Work to be performed by Contractor to the satisfaction of the SAWS COI.
- 5.27 ACCESS REQUIREMENTS - The Contractor shall provide access to residents and businesses affected by the construction of this Project to the greatest extent possible.
- 5.28 SAFETY PRECAUTIONS AND PROGRAMS
- .1 In the performance of this Contract the Contractor shall protect the public, SAWS and the City of

San Antonio by taking reasonable precaution to safeguard persons from death or bodily injury and to safeguard property of any nature whatsoever from damage. Where any dangerous condition or nuisance exists in and around construction sites, equipment and supply storage that are in any manner connected with or arise from the performance of this Contract, the Contractor shall provide and maintain reasonable warning of such danger or nuisance. The Contractor shall not create any dangerous condition or nuisance of any nature whatsoever in connection with the performance of this Contract including, but not limited to, excavations and obstructions, unless necessary to its performance, and in that event the Contractor shall provide and maintain at all times a reasonable means of warning of any danger or nuisance so created. The duties of the Contractor in this paragraph shall be nondelegable and the Contractor's compliance with the specific recommendation and requirements of SAWS as to the means of warning shall not excuse the Contractor from the faithful performance of these duties should such recommendations and requirements not be adequate or reasonable under the circumstances. The Contractor shall take reasonable precautions for the safety of and shall provide protection to prevent damage, injury, or loss to:

- .1 All employees on the Work, and all other persons who may reasonably be foreseen to be affected by the Work.
  - .2 All the Work and all materials to be incorporated at street crossings, along proposed detour routes, and at material stockpiles. Where directed by the Owner or his duly authorized representative, the Contractor shall provide and maintain suitable warning signs, barricades and lights, in accordance with the details included in the Contract Documents, to direct traffic around the Work in progress and to assure the safety of the public. The Contractor shall provide adequate warning signs, barricades, and lights and, where necessary, flagmen for the Project or portions of the Project within which operations are being prosecuted in any one day or which will be closed overnight.
  - .3 Other property at the site or adjacent thereto including but not limited to, trees, shrubs, lawns, walks, pavements, roadways, structures and utilities not designated for removal, relocation or replacement in the course of construction.
- .2 The Contractor shall comply with the U.S. Department of Labor Safety and Health Regulations for construction promulgated under the Occupational Safety and Health Act of 1970 (Public Law 91-596 and all subsequent amendments) and under Section 107 of the Contract Work Hours and Safety Standards Act (Public Law 91-54 and all subsequent amendments). This project is subject to all of the Safety and Health Regulations (CFR 29, Part 1926 and all subsequent amendments) as promulgated by the U.S. Department of Labor on June 24, 1974 and CFR 29, Part 1910 and all subsequent amendments, General Industry Safety and Health Regulations Identified as Applicable to Construction. Contractors shall be knowledgeable with the requirements of these regulations and any amendments thereto.
  - .3 On trench excavation that exceeds a depth of five (5) feet, trench excavation protection shall be accomplished as required by the most current provisions of part 1926 subpart P - Excavations, of the Occupational Safety and Health's Standards and interpretations and as further defined in the note(s) on the Plans and other Contract Documents.
  - .4 In any emergency affecting the safety of persons or property, the Contractor shall act to prevent threatened damage, injury or loss. Any additional compensation or extension of time claimed by the Contractor resulting from emergency Work shall be considered by Owner in accordance with Articles VI and VIII for Completion Time.
  - .5 The Contractor shall provide, at the site, such equipment and medical facilities as are necessary to supply first aid service to anyone who may be injured in connection with the Work. Such equipment shall comply with the most current regulations of the Occupational Safety and Health Administration of the United States Department of Labor.
  - .6 The Contractor must promptly report in writing to the Owner all accidents whatsoever arising out of, or in connection with, the performance of the Work whether on or adjacent to the site which caused death, personal injury, or property damage, giving full details and any statements of witnesses. In addition, if death, serious injury, or serious damage is caused, the accident then

shall be reported immediately by telephone or messenger to the Owner.

- .7 SAWS requires all Contractor job sites shall be immediately accessible to appropriate local, State and Federal agency safety officials.

## **ARTICLE VI. CONTRACT CHANGES:**

- 6.1 CHANGE ORDERS - The Contract Sum and/or the Contract Time may be increased or decreased only by written Change Order. A Change Order signed by the Contractor indicates his acceptance and approval thereof including the adjustment in the Contract Sum and/or the Contract Time. Any compensation paid in conjunction with the terms of a Change Order shall comprise the total compensation due the Contractor for the work or the change defined in the Change Order. By signing the Change Order, the Contractor acknowledges that the stipulated compensation includes payment for the Work of Change plus all payment for the interruption of schedules, stop work orders, extended overhead, delay, or any other impact, claim or ripple effect, and by such signing specifically waives any reservation or claim for additional compensation in respect to the subject of the Change Order. Except as modified by Change Order, all Work performed under a Change Order shall be completed in accordance with these Contract Documents. Each Change Order shall be specific and final as to prices and extensions of time with no reservations or other provisions allowing for future additional money or time as a result of the particular changes identified and fully compensated in the change order.
- 6.2 The Owner, without invalidating the Contract, may order changes in the Work within the general scope of the Contract and applicable law consisting of additions, deletions or other revisions and the Contract Sum and/or the Contract Time will be adjusted accordingly. All such changes in the Work shall be authorized by written Change Order and shall be performed by Contractor under the applicable provisions of the Contract Documents as provided herein.
  - .1 MAJOR CHANGES IN THE WORK - any significant change in a Major Bid Item constitutes a major change in the Work and shall be implemented by a Change Order that shall be binding on the Owner and Contractor. A significant change that constitutes a Major Change in the Work shall be defined as follows:
    - .1 An increase or decrease of five percent (5%) or more in the number of units (not price) for a Major Bid Item as included in the Consultant's estimated quantities included in the Bid Documents; or
    - .2 An increase or decrease of five percent (5%) or more in the dollar value of a lump sum, Major Bid Item.
    - .3 Any change in the Contract Sum resulting from a Major Change in the Work, which reflects among other things, quantity changes, market price changes, and any quantity or volume discounts that might apply, shall be determined as specified in Article 6.5.
  - .2 MINOR CHANGES IN THE WORK - The SAWS COI will have authority to order such minor changes in the Work not involving an adjustment in the Contract Sum or Contract Time and not inconsistent with the intent of the Contract Documents. Such changes shall be implemented by a written directive (a "Work Change Directive") and shall be binding on the Owner and Contractor. The Contractor shall carry out any written directive promptly.
    - .1 If the Contractor does not agree with the SAWS COI that a Minor Change in the work is minor and will result in no adjustment in Contract Sum or Contract Time, he must so notify the Owner in writing, within seven (7) calendar days of issuance of the written directive and prior to beginning any disputed work. If the Contractor fails to file such written notification as provided for above, he shall waive and forever forfeit his rights to file a claim for additional compensation or Time for the Work under this section.
    - .3 In the event there is a Major Change In The Work as provided for in Article 6.2.1, that causes an increase in the number of units for a Major Bid item, Owner may consider a price increase for the Major Bid item for those additional units. In any event the Contractor shall not be entitled to an adjustment of price due to a decrease in a Major Bid Item.



- 6.3 Contractor proposals, along with the supporting data including impact to the critical path, for the proposals as specified in item 6.5.4 shall be submitted no later than seven (7) calendar days after the owner's issuance of an RFP request by Owner's Representative, unless Owner's Representative grants an extension. Failure of contractor to provide the complete and proper proposal including all support will not be cause for delay or additional time.
- 6.4 The entire cost of extra Work resulting from Change Orders including the incremental cost of extra Work resulting from any prior Change Orders, modifications, or additions so ordered, shall not cumulatively exceed twenty-five percent (25%) of the original Contract Sum, in accordance with Texas Local Government Code, Chapter 252 and provided further that the price is agreed upon in writing by Owner and Contractor before materials are furnished or the Work is done. Contractor shall be responsible for keeping records that track the Contractor's cumulative total for Change Orders and Contractor, by entering this Contract, approves, understands and agrees that no Work is approved, no payment will be made, and no Change Order is authorized, that exceed the statutory limit provided herein and any Work undertaken or performed by the Contractor in excess of this amount is at the Contractors sole risk and expense
- 6.5 Changes or Credits for the Work covered by an approved Change Order shall be determined by one or a combination of the following methods:
- .1 UNIT PRICE - Submitted by the Contractor in the original Contractor Bid Proposal as part of the base bid or as a designated additive or deductive alternate, and if agreed to by the Contractor and the Owner, appropriately adjusted either upward or downward to reflect any increases or decreases in the amount of labor, material or equipment as they relate to Major Bid Items.
  - .2 AGREED CONTRACT CHANGES - Lump Sum Agreement between Owner and Contractor as to the price, quantity and time for changes in the Work. The Contractor shall submit an itemized, estimated cost breakdown together with supporting data. This itemized breakdown shall be in accordance with the requirements established in Article 6.5.4 and 6.5.5.
  - .3 FORCE ACCOUNT - If no Agreed Contract Change or unit price can be reached after good faith negotiations between the SAWS and Contractor, the Owner may direct the Work be performed by the Contractor on a Force Account basis, and payment by the SAWS shall be upon the basis of Actual Cost of the Work as specified in Article 6.5.4 plus the participation allowances as specified in Article 6.5.5.
  - .4 ACTUAL COST OF THE WORK – The “Actual Cost” incurred by the Contractor to perform the additional Work. Contractor shall provide a complete breakdown of the Actual Costs to the Owner on a daily basis as follows:
    - .1 Labor including Foremen
    - .2 Labor burden shall be allowed at a maximum of 35%. Any burden in excess of the percentage shown shall be submitted for review and approval by the Owner and will be subjected to audit.
    - .3 Materials comprising the Work
    - .4 The Contractor's actual incremental ownership or rental cost of equipment during the time of use on the extra Work. (Rental cost shall be based on current Southwest Regional AGC, Association of Equipment Distributors regional computations or equivalent).

For Contractor-owned machinery, trucks, power tools or other equipment, necessary for use on Change Order work, the Rental Rate Blue Book for Construction Equipment (hereafter referred to as “Blue Book”) rate, as modified by the following, will be used to establish Contractor's allowable hourly rental rates. Equipment used shall be at the rates in effect for each section of the Blue Book at the time of use. The following formula shall be used to compute the hourly rates:

$$H = \frac{M \times R1 \times R2}{176} + OP$$

176

Where H = Hourly Rate

M = Monthly Rate

R1 = Rate Adjustment Factor

R2 = Regional Adjustment Factor

OP = Operating Costs

If Contractor-owned machinery and/or equipment is not available and equipment is rented from an outside source, the hourly rate shall be established by dividing the actual invoice cost by the actual number of hours the equipment is involved in the Work. Owner reserves the right to limit the hourly rate to comparable Blue Book rates. When the invoice specifies that the rental rate does not include fuel, lubricants, repairs and servicing, the Blue Book hourly operating cost shall be allowed to be added for each hour the equipment operates. The allowable equipment hourly rates shall be paid for each hour that the equipment is involved in the Work and an additional maximum of fifteen percent (15%) may be added as compensation.

- .5 Power and consumable supplies for the operation of power equipment.
- .6 Insurance and any extra bond premiums shall be allowed at a maximum of two (2%) percent of the total change order cost. Any insurance and extra bond premiums in excess of the percentage shown shall be submitted for review and approval by the Owner and will be subjected to audit.

#### .5 PARTICIPATION ALLOWANCE

- .1 For Contractor's proposals covering both increases and decreases in the amount of the Contract, the application of overhead and profit percentages (as provided in the following tables) shall be on the net increase in the Actual Cost for the Contractor or Subcontractor performing the Work. However, where the Contractor or first tier Subcontractor receives proposals for additive and deductive amounts from separate sub tier subcontractors, the commission shall be allowed on the added amounts prior to subtraction of the credit amounts. The cost of such extra Work shall be added to the Contract Sum by a Written Change Order as specified in Article 6.1. The following tables provide further explanation of the application of the provisions in this Article:

| ALLOWABLE MARK UPS      | Work performed by PC                 |       | Work performed by Sub A |       | Work performed by Sub B |       |
|-------------------------|--------------------------------------|-------|-------------------------|-------|-------------------------|-------|
|                         | O & P                                | Comm. | O & P                   | Comm. | O & P                   | Comm. |
| Prime Contractor (PC)   | 20%                                  | ---   | ---                     | 5%    | ---                     | 5%    |
| Subcontractor A (Sub A) | ---                                  | ---   | 20%                     | ---   | ---                     | 5%    |
| Subcontractor B (Sub B) | ---                                  | ---   | ---                     | ---   | 20%                     | ---   |
| Subcontractor C (Sub C) | SAWS Does Not Allow Mark Up On Sub C |       |                         |       |                         |       |

| DEFINITIONS             |                                     |
|-------------------------|-------------------------------------|
| <b>Prime Contractor</b> | Owns the contract with SAWS         |
| <b>Subcontractor A</b>  | Works directly for Prime Contractor |
| <b>Subcontractor B</b>  | Works directly for Subcontractor A  |
| <b>Subcontractor C</b>  | Works directly for Subcontractor B  |
| <b>O &amp; P</b>        | Overhead & Profit                   |
| <b>Comm.</b>            | Commission                          |

| EXAMPLE          | Sub B change order for \$1,000 |          |                   |
|------------------|--------------------------------|----------|-------------------|
|                  | Work performed by Sub B        |          |                   |
|                  | O & P                          | Comm.    |                   |
| Prime Contractor | ---                            | \$63.00  |                   |
| Subcontractor A  | ---                            | \$60.00  |                   |
| Subcontractor B  | \$200.00                       | ---      |                   |
| Subcontractor C  | ---                            | ---      |                   |
| <b>Summary</b>   | CO                             | Mark Up  | CO Total          |
|                  | \$ 1,000.00                    | \$323.00 | <b>\$1,323.00</b> |

6.6 **DELETION OF WORK** - The Owner may, pursuant to Texas Local Government Code, Chapter 252, or as otherwise may be provide by law, order the Contractor to omit up to twenty five percent (25%) of the original Contract Sum and associated Work, as specified in Article 6.4, without the consent of the Contractor.

6.7 **CLAIMS FOR ADDITIONAL COSTS**

- .1 If the Contractor pursues a claim for an increase in the Contract Sum and or time prior to final acceptance, he shall give the Owner written notice thereof with a simultaneous information copy to the Consultant, within thirty (30) days after the Contractor knows, or should have known, of the events giving rise to such Contractor claim. This notice shall be presented in writing to the Owner and Consultant by the Contractor and contractor shall not proceed with work until directed by Owner, except in an emergency endangering life or property in which case the Contractor shall proceed in accordance with Article 5.28.4. No such Contractor claim shall be valid unless the Contractor follows the notice procedure outlined herein, and failure to follow the notice procedure provided above shall cause the Contractor to waive and forever forfeit the right to seek additional amounts on the Contract in regards to the claim. If the Owner and the Contractor cannot agree on the amount of the adjustment in the Contract Sum, if any, it shall be determined by administrative procedures as provided to Article X. Any change in the Contract Sum resulting from such claim shall be authorized by Change Order.
- .2 If the Contractor claims that additional cost will be incurred because of: (1) any written Owner or Consultant interpretation of the Contract Documents, (2) any order by the Owner to stop the Work pursuant to Article 4.8 where the Contractor was not at fault, or (3) any written order involving a perceived minor change in the Work issued pursuant to Article 6.2.2, the Contractor shall make such claim as provided in Article 6.7.1.

6.8 **NO DAMAGES FOR DELAY CLAUSE** - Notwithstanding anything to the contrary in the Contract Documents, an extension in the Contract Time, to the extent permitted under Article 6., shall be the sole remedy of the Contractor for any (i) delay in commencement, prosecution, or completion of Work, (ii) hindrance, interference, suspension or obstruction in the performance of Work, (iii) loss of productivity, or (iv) other similar claims (items (i) through (iv) herein collectively referred to in this Article 6.8 as "Delays") whether or not such Delays are foreseeable, unless a Delay is caused by the acts of the Owner constituting intentional interference with Contractor's performance of the Work, and only to the extent such act continues after the Contractor furnishes Owner with written notice of such interference. In no event shall the Contractor be entitled to any compensation or recovery of any damages, in connection with any Delay, including, without limitation, consequential damages, lost opportunity costs, impact

damages, or other similar remunerations. For purposes of interpreting this provision, the Owner's exercise of any of its rights or remedies under the Contract Documents (including without limitation, ordering changes in Work, or directing suspension, rescheduling, or correction of the Work), regardless of the intent or frequency of the Owner's exercise of such rights or remedies, shall not be construed as intentional interference with the Contractor's performance of the Work.

6.9 SUBCONTRACTOR PASS-THROUGH CLAIMS - In the event that any Subcontractor of Contractor asserts a claim to Contractor that Contractor seeks to pass through to Owner under the Contract Documents, any entitlement to submit and assert the claim as to Owner shall be subject to:

- .1 The requirements herein of these General Conditions; and
- .2 The following additional three (3) requirements listed below, all three (3) of said additional requirements shall be conditions precedent to the entitlement of Contractor to seek and assert such Claim against Owner:
  - (1) Contractor shall:
    - (a) have direct legal liability as a matter of Contract, common law, or statutory law to Subcontractor for the claim that Subcontractor is asserting; or
    - (b) have entered into a written liquidating agreement with Subcontractor, prior to the Claim's occurrence, under which Contractor has agreed to be legally responsible to the Subcontractor for pursuing the assertion of such Claim against Owner under said Contract and for paying to Subcontractor any amount that may be recovered, less Contractor's included markup (subject to the limits in the Contract Documents for any markup). The relationship, liability or responsibilities shall be identified in writing by Contractor to Owner at the time such Claim is submitted to Owner and a copy of any liquidating agreement shall be included by Contractor in the Claim submittal materials.
  - (2) Contractor shall have reviewed the Claim of the Subcontractor prior to its submittal to Owner and independently shall have evaluated such Claim in good faith to determine the extent to which the Claim is believed in good faith to be valid. Contractor shall inform Owner that Contractor has made a review, evaluation, and determination that the Claim is made in good faith and is believed to be valid.
  - (3) Subcontractor making the Claim to Contractor shall certify to both Contractor and Owner that it has compiled, reviewed and evaluated the merits of such Claim and that the Claim is believed in good faith by Subcontractor to be valid. A copy of the certification by Subcontractor shall be included by Contractor in the Claim submittal materials.
- .3 Any failure of Contractor to comply with any of the foregoing requirements and conditions precedent with regard to any such Claim shall constitute a waiver of any entitlement to submit or pursue such Claim.

6.10 TIME REQUIRED TO PROCESS CHANGE ORDERS - All Change Orders require written approval by either Owner or Owners Representative or, where authorized by the State. The approval process requires a minimum of forty-five (45) calendar days **after submission** to Owner in final form with all supporting data. Receipt of a submission by Owner does not constitute acceptance or approval of a proposal, nor does it constitute a warranty that the proposal will be authorized by Owner. **THE TIME REQUIRED FOR THE APPROVAL PROCESS SHALL NOT BE CONSIDERED A DELAY AND NO EXTENSIONS TO THE CONTRACT TIME OR INCREASE IN THE CONTRACT SUM WILL BE CONSIDERED OR GRANTED AS A RESULT OF THIS PROCESS.** Pending the approval of a Change Order as described above, Contractor will proceed with the work under a pending Change Order only if directed in writing to do so by Owner.

## ARTICLE VII. CONTRACT PAYMENTS:

- 7.1 INTERNET-BASED PROJECT MANAGEMENT SYSTEM. SAWS shall administer its services through an Internet-Based Project Management System (hereafter referred to as "CPMS"). In such case, Contractor shall conduct communication through CPMS and perform all Project-related functions utilizing CPMS, with the exception of Sub-Contractor payment monitoring activities, which shall be through the S.P.U.R. system. This includes any and all correspondence, submittals, requests for information, vouchers, compensation requests and processing, amendment, change orders and other administrative activities as may be required in the Contract. SAWS shall administer the CPMS software, shall provide CPMS training to Project Team members and shall make the software accessible via the Internet to all necessary Project Team members. All invoices shall be submitted through the CPMS.

Monthly payments for work performed shall be reviewed by SAWS upon Contractor entering itemized invoices, with all required back-up, within CPMS. The invoice shall indicate the value of the work performed to date.

- 7.2 ESTIMATED QUANTITIES AND MEASUREMENT - The estimated quantities of the various elements of Work to be done and material to be furnished are approximate only and are provided by Consultant and Owner as a basis for Owner comparison of proposals and award of Contract. It is expressly understood and agreed by Owner and Contractor that the actual amounts of Work to be done and material to be furnished may differ somewhat from these estimated quantities. The quantities of Work actually performed by Contractor will be computed on the basis of measurements taken by the Owner's representatives, and these measurements shall be final and binding on Contractor.

PROGRESS PAYMENTS - During the latter part of each month as the Work progresses on all SAWS Contracts regardless of Contract Sum, said Owner, or his designated representatives and Contractor shall determine either the cost of the labor and materials or quantities incorporated into the Work during that month and actual invoiced cost of Contractor acquired materials stored on the Project site, and/or within off-site local storage facilities either owned or leased by the Contractor. Upon receipt of a complete and mathematically accurate Construction Payment Estimate Form from the Contractor, the SAWS shall make payment to Contractor within thirty (30) calendar days of receipt. Contracts totaling four hundred thousand (\$400,000.00) dollars or less, based upon such cost determination and at the Contract unit prices in a sum equivalent to ninety percent (90%) of each such invoice. The remaining ten percent (10%) retainage shall be held by the SAWS until the final Contract Settlement. However, where the Contract amount exceeds four hundred thousand dollars (\$400,000.00), installments shall be paid to Contractor at the rate of ninety-five percent (95%) of each monthly invoice within thirty (30) calendar days of Owner receipt of an approved and mathematically accurate Construction Payment Estimate Form from the Contractor, and the retainage held until final Contract Settlement shall be five percent (5%). In either case, should the Construction Payment Estimate Form submitted by the contractor be incorrect, the Construction Payment Estimate Form will be rejected and returned to the contractor for correction. Upon receipt of the corrected Construction Payment Estimate form, the timeline stated above for payment will apply.

- .1 Contractor's Payment to Sub-Contractors: The contractor will be required to report the actual payments to all subcontractors, utilizing the Sub-contracting Payment and Utilization Reporting (S.P.U.R.) System, in the time intervals and format prescribed by SAWS. This information will be utilized for SMWB participation tracking purposes. Any unjustified failure to comply with the committed SWMB levels may be considered breach of Contract.
- .2 Web Submittal of Subcontractor Payment Reports: The Contractor is required to electronically submit monthly subcontractor payment information utilizing the Sub-contracting Payment and Utilization Reporting (S.P.U.R.) System, beginning with the first SAWS payment for services under the Contract, and with every payment thereafter (for the duration of the contract).

Electronic submittal of monthly subcontractor payment information will be accessed through a link on SAWS' "Business Center" web page. The Contractor and all subcontractors will be provided a unique log-in credential and password to access the SAWS subcontractor payment reporting system. The link may also be accessed through the following internet address: <https://saws.smwbe.com/>

Training on the use of the system will be provided by SAWS. After the prime receives payment from SAWS, electronic submittals will require data entry of the amount paid to each subcontractor listed on the Contractor's Good Faith Effort Plan.

Owner's payment of installments shall not in any way be deemed to be a final acceptance of any part of the Work by Owner, and will not prejudice Owner in the final settlement of Contract account nor relieve the Contractor from completion of the Work as herein provided.

7.3 WITHHOLDING OF PAYMENT - In the event that the Owner discovers evidence of Contractor and/or Work noncompliance with the Contract Documents subsequent to approval of the Construction Estimate Certification Forms, the Owner may revoke or otherwise amend that part of any Construction Estimate Certification Form to such extent as may be necessary to withhold monies to protect the Owner from loss on account of:

- .1 Defective Work not remedied by Contractor.
- .2 Persistent and uncured Contractor non-compliance with the administrative provisions of the Contract Documents including, but not limited to, failure to electronically submit monthly subcontractor payment information utilizing the Sub-contracting Payment and Utilization Reporting (S.P.U.R.) System.
- .3 Damage to Work of another Contractor.
- .4 Liquidated Damages assessed by Owner for Contractor failure to maintain scheduled progress in accordance with the most recent applicable construction schedule, if any are specified in the Contract Documents, and/or Contractor failure to meet final completion date.
- .5 Receipt of written notice by the Owner of Contractor's unpaid bills, as stipulated in Chapter 53, Texas Property Code, if the Contractor has not provided a payment bond and only if the Contract Sum does not exceed \$25,000.00. Any funds so withheld by Owner shall be released to the Contractor if he furnishes either a special indemnity bond to Owner securing release of lien as provided in Chapter 53, Texas Property Code, or Contractor proof of payment of disputed bills.
- .6 "Indemnification" as provided for in Article 2.3.

When the above Contractor deficiencies are cured, Owner will make payment for amounts withheld because of the deficiencies within (30) thirty calendar days.

7.4 FINAL PAYMENT - Contractor shall not be entitled to receive payment of any sum in excess of the cumulative amounts paid upon such monthly invoices as outlined above until after the Owner transmittal of the Letter of Conditional Approval and in accordance to Article 9 project completion and acceptance and not before all the stipulations, requirements and provisions of this Contract are faithfully performed and complied with by Contractor, and unless and until said structures, Work and improvements shall be entirely completed, and delivered to, and accepted by the SAWS in accordance with the Contract Documents. Completion, delivery and acceptance of the Work is evidenced by the Final Certificate of Acceptance issued in accordance to Article 9.1 by the Owner and such Certificate of Acceptance is approved by the Owner. The Owner shall prepare the final invoice as the basis for final Contract settlement. Owner may deduct from the amount of such final invoice and retain any and all sums which are to be deducted by SAWS or paid or allowed by Contractor to SAWS, or which are to be retained by Owner for reasons stemming from any/all fines, fees, or penalties, in addition to those previously stated in Article 7.2.

- .1 NOTARIZED AFFIDAVIT - Before and as a condition precedent to Final Payment for the work by the Owner, the Contractor shall submit to the Owner a notarized affidavit in duplicate stating under oath that all subcontractors, vendors, and other persons or firms who have furnished or performed labor or furnished materials for the work have been fully paid or satisfactorily secured. Such affidavit shall bear or be accompanied by a statement, signed by the surety company who provided the Payment Bond for the work, to the effect that said surety company consents to Final Payment to the Contractor being made by the Owner.

7.5 OWNER TO FINALLY DETERMINE ALL AMOUNTS PAYABLE OR CHARGEABLE - It is expressly understood and agreed by Contractor that subject only to the prices, terms and provisions specifically set forth in the Contract Documents including Change Orders, the written estimates and Certificates of the Owner shall be final in fixing and determining amounts payable or chargeable hereunder to Contractor by SAWS as required by the other terms and conditions hereof. Also, in case of controversy, the monthly construction estimates and Certificates of Final Acceptance shall be final in fixing and determining all sums to be deducted and retained by SAWS for reasons as stated in Article 7.2, out of any funds otherwise estimated as payable to Contractor by SAWS.

7.6 CLAIMS BY THIRD PARTIES FOR LABOR OR MATERIALS

- .1 Contractor hereby agrees to promptly pay all persons supplying labor, services and materials in the prosecution of the Work provided for in this Contract and any and all duly authorized modifications or Change Orders of said Contract that may hereafter be made, and shall fully indemnify and hold harmless the SAWS and its agents against any and all claims, liens, suits or actions asserted by any person, persons, firm or corporation on account of labor, materials or services furnished such Contractor during the prosecution of the Work herein undertaken. Contractor shall execute a payment bond in accordance with other sections governing same herein for this purpose. Before the SAWS shall be obligated to pay any amount to Contractor on final Contract settlement, Contractor shall execute a sworn, written and notarized statement on an affidavit form to be supplied by the Owner along with a "consent of surety" letter endorsing Final Payment to Contractor, evidencing that all labor employed and all equipment and materials incorporated into the Construction of the Work have been either fully paid for by Contractor and Subcontractors, or that any pending disputes over payment are being properly addressed by the surety as provided for in 7.3.1 herein.
- .2 Suppliers, any subcontractors, and persons claiming to have performed any labor, or to have supplied any equipment and materials toward the performance of this Contract, and who claim not to have received proper compensation from the Contractor or Subcontractors for same, shall be instructed by Owner and Contractor that written and documented claims must be sent directly to the Contractor and his Surety in accordance with Chapter 2253, Texas Government Code. The Owner will furnish to claimants, in accordance with such Chapter 2255, Texas Government Code, a copy of the Contractor's Payment Bond and Contract as provided therein upon claimant's written request. **The Owner shall further furnish a statement to claimants that claimants are cautioned that no legal or equitable lien exists on the SAWS funds yet unpaid to the Contractor, and that reliance on notices sent only to the Owner may result in loss of claimant's rights to timely perfect recovery against the Contractor and/or his Surety. The Owner is not responsible in any manner to a claimant for collection of unpaid bills, and accepts no such responsibility because of any unauthorized representation by any agent or employee of Owner to the contrary.**

**ARTICLE VIII. CONTRACT COMPLETION TIME:**

- 8.1 COMMENCEMENT OF WORK - The Work called for in this Contract shall commence on the date indicated in the SAWS written Authorization to Proceed. Under no circumstances shall the Work commence prior to the Contractor's receipt of SAWS issued, written Authorization to Proceed.
- 8.2 COMPLETION OF WORK - After commencement of Work as outlined in Article 8.1, the Contractor shall prosecute the Work continuously, diligently and uninterruptedly throughout the Contract Time period, during which period of time Contractor, all subcontractors and suppliers are bound and obligated at all times to employ sufficient Work force and supervisory diligence to complete said structures, Work and improvements, and to deliver same over to the SAWS in a timely acceptable, completed, undamaged and clean condition. THE TIME OF BEGINNING, RATE OF PROGRESS AND TIME OF COMPLETION OF SAID WORK ARE HEREBY DECLARED BY OWNER AND UNDERSTOOD BY CONTRACTOR TO BE "OF THE ESSENCE" TO THIS CONTRACT. By executing this Contract, Contractor confirms that the Contract Time is a reasonable period for performing the Work. Any other provision contained herein notwithstanding, the Owner may suspend said Work either partially or totally as provided for in Article 4.6 and 4.7.

- 8.3 CALENDAR DAY CONTRACT – Unless otherwise specifically provided in Supplemental or Special Conditions to the Contract, all Contracts shall be Calendar Day Contracts and “Day” as used in the Contract Documents shall mean a calendar day which are days of 24 hours each from midnight to the next consecutive midnight. Work on Sundays or SAWS Designated Holidays will not be permitted except in cases of extreme emergency, and then only with the written permission of the Owner. If Sunday or SAWS Designated Holiday Work is permitted, the COI's average salary costs at time and one half will be charged to the Contractor. This amount shall be deducted from Contractor’s monthly payment application by Owner. Nothing in this Paragraph shall be construed as prohibiting the Contractor from working on Saturdays if so desired provided they give Owner at least the prerequisite forty-eight (48) hours written notice (and receive subsequent approval by the Owner) of intent to perform Work on Saturday so that Owner's representatives may be scheduled to observe/inspect said Work.
- 8.4 FAILURE TO COMPLETE WORK ON TIME - If the Contractor fails to complete the Contract in the time specified by Owner in the Contract Documents and agreed to by Contractor through execution of this Contract, Contract Time charges will continue to be made for each Calendar Day thereafter. THE TIME SET FORTH IN THE CONTRACT FOR THE COMPLETION OF THE WORK IS AN ESSENTIAL ELEMENT OF THE CONTRACT. For each Calendar Day that any Work shall not be complete, after the expiration of the Calendar Days specified in the Contract, (to include Calendar Days charged for correction of Contractor deficiencies found during the final inspection), plus, any extended days allowed by Owner, the amount of liquidated damages assessed per day as stipulated in the Contract will be deducted from the money owed or to become due to the Contractor, not as a penalty but as liquidated damages owed to SAWS for extended expenses, loss and public inconvenience resulting from Contractor's failure to complete said Work within the Contract Time that the Contractor agreed to by execution of this Contract. Contractor and SAWS agree that such liquidated damages as are set prior to the Contract execution are for projected reasonable costs that are otherwise difficult for either Party to forecast and will be incurred by the SAWS due to Contractor completion beyond the number of Calendar Days calculated herein by the SAWS.
- .1 The Contract Time may only be changed by a Change Order duly executed by both Contractor and Owner.
  - .2 Should progress of the Work fall behind the construction schedule except for reasons stated in 8.4.1, Contactor shall promptly submit at the request of Owner or Authorized Representative an updated Construction schedule to Owner or Authorized Representative for approval. Contractor shall take any and all action necessary to restore progress by working the hours, and lawful overtime operations as necessary to achieve Contract Time.
- 8.5 WEATHER DELAY CLAUSE - SAWS includes weather delay days when determining the total number of days allowed for each Contract. Any additional days beyond those specified in 8.5.3 must be formally requested in writing with the next monthly payment invoice and justified by the contractor with daily logs or NO ADDITIONAL DAYS WILL BE GRANTED.
- .1 Pursuant to the Contract, Contractor may be granted an extension of time because of unusual inclement weather, including but not limited to unusual rainfall events, which are beyond the Normal Rainfall recorded and expected for San Antonio, Texas. However, the Contractor will not be granted an extension of time for “Normal Rainfall”, as described in 8.5.3.
  - .2 "Unusual Inclement Weather" is defined as a rain event or other weather related event which occurs at the site and is of sufficient magnitude, as determined by the COI, to prevent Contractor from performing work critical to maintaining the Progress Schedule. If rain is the basis for the Unusual Inclement Weather event it must at a minimum exceed the Normal Rainfall as defined herein.
  - .3 Baseline Rain Day Determination. “Normal Rainfall”, based on the National Oceanic and Atmospheric Administration (NOAA) or similar data for San Antonio, Texas, is considered a part of the Calendar Day Contract, and is not a justification for an extension of time. Listed below are the number of days in each month for which no compensatory days for rainfall events (“Rain



Days”) in such months may be claimed:

|                |        |
|----------------|--------|
| January.....   | 2 days |
| February.....  | 3 days |
| March.....     | 4 days |
| April.....     | 3 days |
| May.....       | 4 days |
| June.....      | 6 days |
| July.....      | 3 days |
| August.....    | 4 days |
| September..... | 5 days |
| October.....   | 5 days |
| November.....  | 5 days |
| December.....  | 3 days |

“Rain Days” in addition to the baseline “Rain Day” determination described above will be measured (with the Owner’s Representative’s approval) at the jobsite or at a location as agreed in writing by the parties.

- .4 Contractor may receive credit in any month for Unusual Inclement Weather, and specifically for any Rain Days in that month which exceed the number of Rain Days allocated to that month, if a Claim is made in accordance with paragraph 8.5.1 and the weather event meets the definition for "Unusual Inclement Weather", and as applicable, “Rain Day” and such claimed day is a day on which Work critical to maintaining the Progress Schedule is scheduled to be performed and is otherwise capable of being performed.

- 8.6 Liquidated Damages for Failure to Complete on Time – The Contractor agrees that **Time Is Of Essence** of this Contract and that for each day of delay beyond the number of days herein agreed upon for the completion of work herein specified and contracted for, after due allowance for such extension of time as is provided for under the provisions herein, the Owner may withhold permanently for the Contractor's total compensation, not as a penalty but as liquidated damages, the sum per day in accordance to the Supplemental Conditions of the Contract.

**ARTICLE IX. PROJECT COMPLETION AND ACCEPTANCE:**

- 9.1 FINAL ACCEPTANCE of the Project will be considered only after all stipulations, requirements and provisions of this Contract are faithfully completed and the Project is delivered to the SAWS by Contractor in an acceptable condition for the intended use by Owner. In the event that all major Contract pay items are complete and only minor clean-up operations remain for Contract completion, the Owner has the discretionary authority to issue a Conditional Letter of Acceptance. Should the Owner’s Conditional Letter of Acceptance contain conditions for the Final Acceptance of the Work, Contract Time will continue to be charged against the Contractor until such conditions have been corrected to the satisfaction of the Owner.

- .1 Final Release of Retainage - Contractor shall be entitled to receive payment of all retainage within forty-five (45) calendar days of completion, receipt and acceptance of all required "completion items" as stipulated below:
  - .1 The “Semi-Final Pay Request” indicating that no additional monthly invoices will be submitted by the Contractor for payment.
  - .2 The “Conditional Letter of Acceptance” with all “Punch List Items” completed indicating that Owner is approving the Release of Retainage.
  - .3 When applicable, the “Recapitulation Change Order” reconciling all Pay Item Quantities. Recapitulation Change Orders exceeding \$100,000 positive or negative are subject to formal Board of Trustee approval.
  - .4 The “Contractor Certification” provided for herein indicating that all subcontractors and suppliers have been paid.

- .5 The "Consent of Surety" provided for herein indicating the Bonding Agent's approval to remit all retainage directly to the Contractor.
  - .6 When applicable, the "TWDB Certificate of Approval & Release of Retainage" letter indicating Texas Water Development Board's approval to remit all retainage directly to the Contractor.
- 9.2 PARTIAL ACCEPTANCE by Owner for beneficial occupancy of any completed part of the Work, which has specifically been identified in the Contract Documents as being eligible for early Owner Acceptance, or which Owner, Engineer and/or Consultant and Contractor agree constitutes a separately functioning and usable part of the Work that can be used by Owner without significant interference with Contractor's performance of the remainder of the Work, may be accomplished prior to completion of the total Work identified in the Contract Documents, subject to the following:
- .1 Owner may at any time request Contractor in writing to permit Owner to beneficially occupy any such part of the Work which Owner believes to be ready for its intended use. If Contractor agrees, Contractor will certify to Owner and Consultant that said part of the Work is substantially complete and request the Owner to issue a Conditional Letter of Acceptance, for only that part of the Work. Within a reasonable time after such request, Owner, Contractor, Engineer and/or Consultant shall make an inspection of the said part of the Work to determine its status of completion. Warranties (as provided under Article 9.3) on that part of the Work beneficially occupied by Owner will commence upon issuance of the Conditional Letter of Acceptance. Any Work items remaining to be completed as defined in the Conditional Letter of Acceptance for the said part of the Work will have warranty commencement upon completion and Final Acceptance by Owner.
  - .2 Owner may at any time request Contractor in writing to permit Owner to take over operation of any such part of the Work although it is not Substantially Complete. A copy of such request will be sent to the Engineer and within a reasonable time thereafter, Owner, Contractor, and Engineer and/or Consultant, shall make an inspection of that part of the Work affected by the request to determine its status of completion and will jointly prepare a list of the items remaining to be completed or corrected issuance of a Conditional Letter of Acceptance. If Contractor does not agree that said part of the Work is ready for separate operation by Owner or that separate operation by Owner will not significantly interfere with Contractor's remaining operations, the Contractor must submit their objections and appropriate justifications in writing to the Owner and Engineer and/or Consultant within 5 days of the request by the Owner. Once any objections have been addressed or if there are no objections, the Owner will finalize a list of items to be completed or corrected and will deliver such list to Contractor together with a written recommendation as to the division of responsibilities pending issuance of the Conditional Letter of Acceptance with respect to security, operation, safety, maintenance, warranties, utilities, insurance, and retainage for that part of the Work taken over for operation by Owner. During such operation, Owner shall allow Contractor reasonable access to complete or correct items on said list and to complete other related Work.
- 9.3 Correction Period/Warranty - During a period of twenty four (24) months from and after the date of the Conditional Letter of Acceptance, the Contractor shall make all needed repairs arising out of defective workmanship or materials, or both, which in the judgment of the Owner shall become necessary during such period. The Owner shall notify and submit a "Performance Claim Form", which will be completed by the Owner and details the location and nature of needed repairs, to the Contractor. The Contractor shall submit a schedule for inspection and completion of said repairs within three (3) days after the notification of the warranty repairs to be approved by the Owner. If within three (3) days after the receipt of a notice in writing from the Owner, the Contractor shall neglect to make or to undertake with due diligence the aforesaid repairs, the Owner is hereby authorized to make demand of performance from the company issuing the Performance Bond. If the Contractor fails to complete the repairs within the approved schedule, the Owner is hereby authorized to make demand of performance from the company issuing the Performance Bond. In case of an emergency where, in the judgment of the Owner, delay would cause a serious loss or damage, repairs may be made without notice being sent to the Contractor, and the Contractor shall pay the cost thereof.

**ARTICLE X. DISPUTES:**

- 10.1 GENERAL - Prior to any anticipated litigation between the Owner and the Contractor, both hereby agree that disputed matters shall first be submitted to Owner administrative appellate procedures as described below:
- .1 Except as otherwise provided in this Contract, any dispute concerning a question of fact arising under this Contract which is not disposed of by mutual agreement shall be initially decided by the Owner (as represented by the decision of the Owner) who shall reduce his decision to writing and promptly mail or otherwise furnish a copy thereof to the Contractor. The decision of the Owner shall be final and conclusive unless within thirty (30) calendar days from the date of issuance of such decision by Owner the Contractor mails or otherwise furnishes to the Owner a written notice of appeal addressed to the SAWS President/C.E.O., whose appellate decision on behalf of the SAWS shall be the final and conclusive SAWS decision. In connection with any appeal under this Article, the Contractor shall be afforded an opportunity to be heard and to offer evidence in support of the appeal to persons to be promptly appointed by the SAWS President/C.E.O. to review such disputed matters. The SAWS department sponsoring the Project or any other Owner's representative will also be allowed to present information supporting Owner's position.
  - .2 Pending final President/C.E.O. decision after a dispute hearing, the Contractor shall proceed diligently with the performance of the Contract and in accordance with the President/C.E.O. decision. Neither the SAWS nor the Contractor is precluded from resorting to litigation or other remedy at law nor in equity to perfect a legal filing prior to the expiration of an applicable statute of limitations or after this Owner administrative review process is completed.
- 10.2 PREVAILING PARTY. In any dispute arising under this Agreement, the following shall apply in the determination of which party is the prevailing party. If a party claiming a right to payment of an amount in dispute is awarded all or substantially all of such disputed amount, then such claiming party shall be the prevailing party. If a party defending against such claim is found to be not liable to pay all or substantially all of the disputed amounts claimed by the claiming party, then the party so defending against such claim shall be the prevailing party. If both Parties prevail with respect to different claims by each of them, then the party who is prevailing with respect to the substantially greater monetary sum shall be deemed the prevailing party; otherwise, if both Parties prevail with respect to monetary sums on different claims, neither of which sums is substantially greater than the other, the tribunal having jurisdiction over the controversy, claims or actions shall in rendering the award determine in its discretion whether and to what extent either party should be entitled to recover any portion of its attorney fees. The Prevailing Party shall be entitled to recover reasonable attorney fees and costs.

**ARTICLE XI. SUPPLEMENTAL AND SPECIAL CONDITIONS:**

- 11.1 GENERAL - When the Work contemplated by the Owner is of such a character that the foregoing Standard General Conditions of the Contract cannot adequately cover necessary and additional contractual provisions, the Contract Documents may include Supplemental and Special Conditions as described below:
- .1 SUPPLEMENTAL CONDITIONS shall describe any additional procedures and requirements of Contract administration to be followed by the Contractor, Owner, and Owner representatives. Supplemental Conditions may expand upon matters covered by the Standard General Conditions, where necessary.
  - .2 SPECIAL CONDITIONS shall relate to terms, conditions and procedures related to a specific project and that are unique to that project.
- 11.2 ARCHAEOLOGICAL - "Unidentified Archaeological Sites": If the Contractor should encounter archaeological deposits during construction operations, the Contractor must stop excavation immediately and contact the Owner, who will then contact appropriate agencies for an archaeological investigation. The Contractor cannot begin excavation again in this area without written permission from the Owner.

- 11.3 FUNDED PROJECTS - On State or Federally funded projects, the Owner may waive, suspend, or modify any Article in these General Conditions which conflicts with any State or Federal statute, rule, regulation or procedure, where such waiver, suspension, or modification is essential to receipt by the Owner of such State or Federal funds for the Project. In the case of any project financed in whole or in part by State or Federal funds, any Contract standards or provisions required by the enabling State or Federal statute, or any State or Federal rules, regulations or procedures adopted pursuant thereto that conflict with, or preempt these local Standard General Conditions, shall be controlling.

**ARTICLE XII. RIGHT TO AUDIT CLAUSE:**

- 12.1 By execution of the Construction Contract, the Contractor grants the Owner the right to audit, at the Owner's election, all of the Contractor's records and billings relating to the performance of the Work under the Contract Documents. The Contractor agrees to retain its Project records for a minimum of three (3) years following completion of the Work. The Owner agrees that it will exercise the right to audit only at reasonable hours. Any payment, settlement, satisfaction, or release provided under this Contract shall be subject to the Owner's rights as may be disclosed by any audit.

**ARTICLE XIII. VENUE:**

This Contract is performed in Bexar County, Texas, and if legal action is necessary to enforce this Contract, exclusive venue shall lie in Bexar County, Texas.

- END -

# CONTRACT

**B-19-017-AT**  
**Job No. 19-0132**

STATE OF TEXAS §  
COUNTY OF BEXAR §

## KNOW ALL MEN BY THESE PRESENTS:

That this Agreement made and entered into this «Board Date» day of «Board Month», A.D.,«Board Year», by and between **THE SAN ANTONIO WATER SYSTEM BOARD OF TRUSTEES**, hereinafter called **THE SAN ANTONIO WATER SYSTEM, COUNTY OF BEXAR, STATE OF TEXAS**, Acting through its Contracting Officer, First Party, hereinafter termed the Owner, and «Company Name», of the City of «City», County of «County», State of «State », Second Party, hereinafter termed the Contractor.

**WITNESSETH:** That for and in consideration of the payments and agreements hereinafter mentioned to be made and performed by said First Party, (Owner), the said Second Party, (Contractor), hereby agrees with the First Party to commence and complete the construction of certain improvements in the amount of «Written Contract Amt» Dollars «Formatted Price», for the San Antonio Water System Job No(s). «Bid Opening Date», dated «Bid Opening Date», the same being designated as San Antonio Water System Project Clouse WRC Perimeter Fence.

The Contractor shall perform all work shown on the Plans and described Specifications and shall meet all requirements of this Agreement, The General and Special Conditions of the Agreement; and such Orders and Agreements for Extra Work as may subsequently be entered by the above named parties to this Agreement.

The Contractor shall not offer, confer, or agree to confer any benefit or gift to any San Antonio Water System employee and Water System employees are prohibited from soliciting, accepting or agreeing to accept any gifts from outside sources; please see Section M. – Gifts or Benefits of the Water System’s Code of Ethical Standards. Section M of the Water System’s Code of Ethical Standards regarding Gifts or Benefits is available on the SAWS Business Center website.

The Contractor hereby agrees to commence work under this Contract on the date indicated in the SAWS written Authorization to Proceed. Under no circumstances shall the work commence prior to the Contractor's receipt of SAWS issued, written Authorization to Proceed. Computation of Contract Time will begin on the construction start date as indicated on the written Authorization to Proceed. All work specified in these Contract Documents shall be completed within 60 calendar days from the construction start date **or until funds are exhausted, whichever comes first (delete if not applicable)** indicated on the written Authorization to Proceed.

It is agreed and understood by the Owner and the Contractor that the provisions of Chapter 252, Texas Local Government Code, and/or Chapter 2269, Texas Government Code (as amended) apply to this contract. As applicable, the terms of the aforementioned state law are incorporated herein by reference. Contractor and Owner agree that pursuant to state law, Owner authorizes its duly designated administrative officer (Contracting Officer) to negotiate change orders up to and including the amount of \$100,000.00. It is also agreed and understood that any change orders which increase the cost of the work provided under the contract in excess of 25% of the original contract price are prohibited. The cost of the work provided under the contract may be decreased over 25% of the original contract price with the consent of the Contractor.

The Owner agrees to pay the Contractor in current funds, and to make payments on account, for the performance of the work in accordance with the Contract, at the prices set forth in the Contractor's Proposal, subject to additions and deductions, all as provided in the General Conditions of the Agreement.

The following documents, together with this Contract, comprise the Agreement, and they are as fully a part thereof as if herein repeated in full:

- The Invitation to Bidders or Invitation for Competitive Sealed Proposals
- The Instructions to Bidders or Instructions to Respondents
- The Supplementary Instructions to Respondents (if applicable)
- The Bid Proposal or Price Proposal
- The Payment Bond
- The Performance Bond
- The General Conditions of the Contract
- The Special Conditions of the Contract
- The Supplemental Conditions of the Contract
- The Construction Specifications
- The Standard Drawings
- Addenda
- Change Orders
- Good Faith Effort Plan

The Plans, designated San Antonio Water System Project 19-0132; Clouse WRC Perimeter Fence.

In witness thereof of the Parties of these presents have executed this Agreement in the year and day of first above written.

The individuals executing this Contract each represent and warrant to the other party that he/she has full authority to execute this Contract on behalf of his/her respective party.

**SAN ANTONIO WATER SYSTEM BOARD  
OF TRUSTEES, OWNER**

By \_\_\_\_\_

*«Contracting\_Director»  
Director - Contracting*

Date: \_\_\_\_\_

By \_\_\_\_\_

*Contractor*

By \_\_\_\_\_

*(Signature)*

\_\_\_\_\_  
*(Print/Type Name)*

Title \_\_\_\_\_

Date: \_\_\_\_\_

**STATUTORY PERFORMANCE BOND**  
**Pursuant to Vernon's Texas Government Code**  
**Title 10, Chapter 2253, as amended**

**Bond No.** \_\_\_\_\_

(Penalty of this Bond must be 100% of Contract Award)

KNOW ALL MEN BY THESE PRESENTS:

That «Company Name» «Street Address» «City and State» «Zip Code» (hereinafter called "Principal"), as Principal, and «Surety Name», a Corporation organized and existing under the laws of the State of «Suretys State », with its principal office in the City of «City of Suretys Principal Office», and authorized under the laws of the State of Texas to act as surety on bonds for principals (hereinafter called "Surety"), are held and firmly bound unto THE SAN ANTONIO WATER SYSTEM BOARD OF TRUSTEES, San Antonio, Bexar County, Texas (hereinafter called "Owner/Obligee"), in the amount of «Written Contract Amt». Dollars «Formatted Price», for the payment whereof, Principal and Surety firmly bind themselves, and their heirs, administrators, executors, successors and assigns, jointly and severally, by these presents:

WHEREAS, Principal has entered into a certain written contract with the Owner/Obligee, dated the «Board Date» day of «Board Month», «Board Year», consisting of Job No. 19-0132; Clouse WRC Perimeter Fence (hereinafter called "the Contract"), which Contract is hereby referred to and made a part hereof as fully and to the same extent as if copied at length herein.

**NOW, THEREFORE, THE CONDITION OF THIS OBLIGATION IS SUCH**, that if Principal shall faithfully perform the work in accordance with the plans, specifications and Contract Documents, then this obligation shall be void; otherwise to remain in full force and effect.

**NOW, THEREFORE**, if Principal shall repair any and all defects in said work occasioned by and resulting from defect in materials furnished by, or workmanship of, Principal in performance of the work covered by the Contract, occurring during a period of within 24 months from the date of the Contract Completion Certification, therein this obligation shall be null and void; otherwise to remain in full force and effect.

**PROVIDED, HOWEVER**, that this bond is executed pursuant to the provisions of Title 10, Chapter 2253, as amended, of the Texas Government Code, and all liabilities on this bond shall be determined in accordance with the provisions of this Chapter, to the same extent as if it were copied at length herein.

Surety, for value received, stipulates and agrees that no change, extension of time, or other waiver or amendment of the terms of the Contract or to the work to be performed thereunder, nor any change in the method nor any change in the method or amount of payments stipulated to be made by Owner/Obligee under the Contract, shall relieve Surety of its obligations hereunder, and Surety hereby waives notice of any such change, extension of time, waiver or amendment of the terms of the Contract or to the work to be performed thereunder. The bond shall be automatically extended in time, without formal and separate amendment, to cover full and faithful performance of the Contract in the event of modification of the Contract, regardless of the length of time involved.

**IN WITNESS THEREOF**, Principal and Surety have signed and sealed this instrument on \_\_\_\_\_ day of \_\_\_\_\_, 2019.

**Principal**

**Surety**

By \_\_\_\_\_  
Title \_\_\_\_\_  
Address \_\_\_\_\_

By \_\_\_\_\_  
Title \_\_\_\_\_  
Address \_\_\_\_\_

**Name, Address and Telephone Number of Resident Agent of Surety:**

---

**STATUTORY PAYMENT BOND**  
**Pursuant to Vernon's Texas Government Code**  
**Title 10, Chapter 2253, as amended**

**Bond No.** \_\_\_\_\_

(Penalty of this Bond must be 100% of Contract Award)

KNOW ALL MEN BY THESE PRESENTS:

That «Company Name»«Street Address»«City and State»«Zip Code» (hereinafter called "Principal"), as Principal, and «Surety Name», a corporation organized and existing under the laws of the State of «Suretys State », with its principal office in the City of «City of Suretys Principal Office», and authorized under the laws of the State of Texas to act as surety on bonds for principals (hereinafter called "Surety"), are held and firmly bound unto THE SAN ANTONIO WATER SYSTEM BOARD OF TRUSTEES, San Antonio, Bexar County, Texas (hereinafter called "Owner/Obligee"), in the amount «Written Contract Amt» Dollars «Formatted Price», for the payment whereof, Principal and Surety firmly bind themselves, and their heirs, administrators, executors, successors and assigns, jointly and severally, by these presents:

WHEREAS, Principal has entered into a certain written contract with the Owner/Obligee, dated the «Board Date» day of «Board Month», «Board Year» consisting of Job No. 19-0132; Clouse WRC Perimeter Fence (hereinafter called "the Contract"), which Contract is hereby referred to and made a part hereof as fully and to the same extent as if copied at length herein.

**NOW, THEREFORE, THE CONDITION OF THIS OBLIGATION IS SUCH**, that if Principal shall faithfully pay in full all claimants supplying labor and material to Principal or to a subcontractor in the prosecution of the work provided for in the terms of the Contract Documents, then this obligation shall be void; otherwise to remain in full force and effect.

**PROVIDED, HOWEVER**, that this bond is executed pursuant to the provisions of Title 10, Chapter 2253, as amended, of the Texas Government Code, and all liabilities on this bond shall be determined in accordance with the provisions of this Chapter, to the same extent as if it were copied at length herein.

Surety, for value received, stipulates and agrees that no change, extension of time, or other waiver or amendment of the terms of the Contract or to the work thereunder, nor any change in the method nor any change in the method or amount of payments stipulated to be made by Owner/Obligee under the Contract, shall relieve Surety of its obligations hereunder, and Surety hereby waives notice of any such change, extension of time, waiver or amendment of the terms of the Contract or to the work thereunder. The bond shall be automatically extended in time, without formal and separate amendment, to cover full and faithful performance of the Contract in the event of modification of the Contract, regardless of the length of time involved.

**IN WITNESS THEREOF**, Principal and Surety have signed and sealed this instrument on the \_\_\_\_\_ day of \_\_\_\_\_, 2019.

**Principal**

**Surety**

By \_\_\_\_\_

By \_\_\_\_\_

Title \_\_\_\_\_

Title \_\_\_\_\_

Address \_\_\_\_\_

Address \_\_\_\_\_

**Name, Address and Telephone Number of Resident Agent of Surety:**

\_\_\_\_\_



## EXHIBIT B

### ADMINISTRATIVE AND OPERATIONAL PROCEDURES FOR CONTRACTOR BID SUSPENSION HEARINGS AND APPEALS

#### I. SCOPE

These Administrative and Operational Procedures for Contractor Bid Suspension Hearings and Appeals apply to all contractors awarded contracts with SAWS.

The term “contractor” as used in these Procedures means a construction contractor, subcontractor, vendor, supplier, materialman or any other person or entity supplying labor or material to SAWS on a contract basis.

"SAWS Management Officials" means SAWS personnel who are at the Manager level or above and who are involved in the supervision, review or acceptance of services, work or materials provided by contractors under contract with SAWS.

#### II. GENERAL PROCEDURES

A. If a SAWS Management Official determines that a particular contractor’s responsiveness, capabilities or performance under one or more SAWS contracts is unsatisfactory, the SAWS Management Official may file a complaint with the Chief Operating Officer recommending that the particular contractor be suspended from consideration for award of contracts with SAWS. A complaint may not be filed unless:

- 1) SAWS has sent the contractor at least three letters advising that the contractor is in non-compliance with a contract with SAWS, and the letters each include a warning that further defaults or breaches may lead to a suspension; or
- 2) the contractor has had a previous contract with SAWS terminated for contractor default; or
- 3) either the City of San Antonio or the State of Texas has suspended the contractor.

B. A SAWS Management Official filing a complaint will provide the Contracting Committee with any information he or she may have relating to the Reasons for Contractor Suspension as described in Section 4.9, Contractor Bid Suspension Policy of the General Conditions.

- C. SAWS will maintain the materials relating to any and all complaints filed against a particular contractor in a “complaint file” pertaining to the contractor.
- D. A contractor may be suspended if the contractor is determined by the Contracting Committee to be not sufficiently responsible to warrant consideration for award of contracts with SAWS.

### III. RIGHTS AT HEARING

A hearing on a complaint will be held before a Contracting Committee which will review the evidence presented at the hearing and make a determination as to whether the contractor should be suspended. The Committee will select a chair to preside at the hearing. At the hearing, SAWS and the contractor will each have the following rights and opportunities:

- A. to be heard before an impartial committee;
- B. to be represented by an attorney or a representative of choice;
- C. to hear the witnesses and other evidence presented by the opposing party;
- D. to cross-examine adverse witnesses;
- E. to testify on one’s own behalf;
- F. to present witnesses and other evidence on one's own behalf;
- G. to have a record of the hearing made, by transcript, tape, or otherwise;
- H. to have all testimony presented under oath.

### IV. COMMITTEE PROCESS

- A. The President/Chief Executive Officer of SAWS shall appoint a standing Contracting Committee comprising of SAWS staff. At least one Committee member will be a Vice President of SAWS and all other Committee members will be Managers or higher. If a standing Contracting Committee member has been involved in the day-to-day administration or supervision of a contract with a contractor being reviewed by the Committee, such Committee member will not serve on the Committee with regard to a complaint or appeal affecting that contractor. The President/CEO may either appoint a substitute or the Committee may proceed with fewer members, but in no event will there be less than three members available at any Committee meeting to hear evidence or take action on a complaint or appeal. The members of the Committee

hearing the complaint will be SAWS Management Officials not directly involved with the contractor being considered for bid suspension.

- B. When a SAWS Management Official submits a complaint to the Chief Operating Officer, the Chief Operating Officer will review the complaint to determine whether to convene the Contracting Committee to hear and act on the complaint. The Committee will be convened on a case-by-case basis.
- C. The Contracting Committee will review evidence, obtain testimony from witnesses, deliberate and vote on the matters brought before the Committee. The Committee will consider (i) all evidence in the complaint file pertaining to the contractor and any previously filed complaints and (ii) any other relevant evidence pertaining to the contractor, including evidence presented by SAWS Management Officials familiar with the contractor's performance.
- D. After considering all relevant evidence, the Contracting Committee will either:
  - 1) take no action other than sending a written warning notice by certified mail, return receipt requested, to the contractor (i) indicating that pursuant to these procedures, the Committee has received a complaint regarding the contractor, (ii) indicating that after reviewing the complaint and related evidence, the Committee has decided, at this time, to take no action regarding the contractor, and (iii) including any other information that the Committee, in its discretion, deems appropriate; or
  - 2) pursuant to these procedures, suspend the contractor from consideration for awards of contracts with SAWS.
- E. If the Contracting Committee decides to suspend the contractor, the Committee will send written notice as described in General Conditions, Section 4.7, Contractor Bid Suspension Policy, indicating the following:
  - 1) that, pursuant to these procedures, the contractor has been suspended from consideration for award of contracts with SAWS;
  - 2) in general terms, the reasons for the suspension;
  - 3) that the suspension commences upon issuance of the notice of suspension;
  - 4) the length of time and other relevant terms of the suspension as delineated in these procedures;

- 5) that bids or proposals will not be accepted or solicited from the contractor, and if they are received, they will not be opened and considered for award during the suspension period; and
- 6) the Contractor's right to appeal the suspension pursuant to these procedures.

## V. PROCEDURE AT HEARING

The procedure described below will be followed in a general sense. The Contracting Committee may vary these procedures when necessary because of circumstances.

### A. Copies of Exhibits

Whenever possible, the party wishing to introduce exhibits should make sufficient copies ahead of time. This will prevent interruptions and delays of the proceedings. Generally, in addition to those to be used by the party and the witness, copies will be made available to each of the Committee members, one for the official record and one for the representative of the other party.

### B. Order of Presentation

- After the beginning formalities, each party will be allowed an opportunity to make a brief introductory statement.
- Initially, SAWS will present the evidence it believes warrants the suspension. As each witness is called, the contractor or the contractor's attorney/representative will have the right to cross-examine the witness after the witness has testified and before the next witness is called. The contractor or the contractor's attorney/representative may object to testimony and exhibits.
- After the presentation of SAWS' evidence, the contractor may present evidence, including his or her own testimony and that of others. As each witness is called, SAWS will have the right to cross-examine each witness after the witness has testified and before the next witness is called. A SAWS Management Official may object to testimony and exhibits.
- After the contractor has presented his/her case, SAWS may recall witnesses and present additional witnesses or evidence, again subject to cross-examination and objections. After this, the contractor may recall witnesses and present additional witnesses or evidence, also subject to cross-examination and objections.
- Each party may be allowed additional time to present further rebuttal evidence.

- After the presentation of the evidence, and before the close of the hearing, each party will have the opportunity to give a brief closing argument or summary of his/her position. The Committee may limit the time available to each of the parties depending on the amount of evidence, issues, or other circumstances the Committee deems appropriate.
- The Committee will ensure the orderly and efficient presentation of the evidence.
- The Committee will rule on any objection to testimony or other evidence.
- The Committee will have the right to prevent any threatening or abusive language or conduct and to exclude witnesses who engage in conduct that is disruptive of the proceedings.
- Stipulations (i.e., agreements between all affected parties) which expedite the proceedings are highly favored. Therefore, both SAWS and the contractor are encouraged to reach agreements regarding the admissibility of documents and the proposed testimony of witnesses. Where both SAWS and the contractor (or his/her attorney/representative) have agreed in writing or “on the record,” affidavits of absent witnesses may be introduced.
- All testimony will be under oath. The Committee chair or his/her designee will administer the oaths.
- In its discretion, the Committee may limit or exclude testimony that is superfluous or irrelevant.
- The Committee will utilize its discretion regarding the amount of time allowed for each proceeding and will have the authority to make decisions that will expedite the proceedings.
- In the Committee's discretion, Committee members may ask questions of any witness or party when they believe clarification or further information is needed.
- Unless testifying as an expert, no witness may testify unless he or she has personal knowledge regarding the issues, events, and matters relevant to the hearing.
- The Committee may exclude or limit witnesses who do not have personal knowledge regarding the issues, events, and matters relevant to the hearing.
- The Committee may take other appropriate action when the contractor fails to attend the hearing.

## VI. POSTPONEMENTS

Postponements are not favored. However, where emergency circumstances are beyond the control of the contractor, the Contracting Committee will consider postponing the hearing. There will be no guarantee that a second postponement will be granted.

## VII. SUSPENSIONS

- A. If the contractor has not been previously suspended pursuant to these procedures, the term of the suspension will be for one year from the date of issuance of the notice of suspension.
- B. If the contractor has been previously suspended pursuant to these procedures, the term of the suspension will be for two years from the date of issuance of the notice of suspension.
- C. After the suspension period is over, the contractor may resume submitting bids for SAWS contracts, provided, however, that initially SAWS will award no more than one contract to the suspended contractor. Only after the satisfactory completion of such contract will SAWS resume considering the award of multiple contracts to the contractor. The period of time after the suspension period is over but before SAWS will consider awarding multiple contracts to the contractor is referred to as the “post-suspension period.” The purpose of the post-suspension period is to provide SAWS an opportunity to confirm that the contractor has demonstrated a satisfactory level of responsibility to warrant the award of further SAWS contracts.
- D. Unless the Contracting Committee, in its sole discretion, decides otherwise, during the suspension period and the post-suspension period the contractor may not provide SAWS with labor or materials as a contractor or a subcontractor through another contractor. (This provision does not apply to the single contract that may be awarded to the contractor by SAWS during the post-suspension period or to any contracts or subcontracts in effect prior to the issuance of the notice of suspension.)
- E. If another contractor (“other contractor”) hires a suspended contractor to provide labor or material on a SAWS project while the contractor is suspended from SAWS work, SAWS may notify the other contractor that he or she has 30 days in which to remove the suspended contractor from the SAWS project. If the other contractor does not remove the suspended contractor from the SAWS project within thirty (30) days, SAWS may either (i) reject the portion of the other contractor’s work performed by the suspended contractor because it was performed by a suspended contractor, or (ii) immediately terminate the other contractor’s contract for the project.

Continued use of a suspended contractor after the thirty (30) day notice and cure period will be an event of default under any contract the other contractor has with SAWS under which the suspended contractor provides labor and/or materials.

- F. Notwithstanding the foregoing, a suspended contractor may provide equipment to SAWS as a subcontractor through another contractor, unless the Contracting Committee, in its sole discretion, decides otherwise. In addition, any contractor may hire employees of a suspended contractor as its employees and use them on a SAWS project.
- G. Unless the Contracting Committee, in its sole discretion, decides otherwise, if one or more of the former principal officers or owners of a suspended contractor forms a new business entity or joins a different business entity, or if the suspended contractor is reconstituted as or made a part of a new or different business entity by any means, the terms of the suspension will apply to the new or different business entity as if the new or different business entity were one and the same as the suspended contractor.
- H. All bids for contracts submitted to SAWS by the contractor prior to the issuance of the notice of suspension and all contracts existing between SAWS and the contractor prior to the issuance of the notice of suspension will remain valid and effective on their own accord regardless of the suspension. Notwithstanding the suspension, both SAWS and the contractor will remain obligated to perform all duties owed one another pursuant to any contracts or subcontracts in effect prior to the issuance of the notice of suspension.

## VIII. APPEALS

- A. A suspended contractor may request an appeal hearing regarding the suspension, provided such request is received in writing by the Contracting Committee within ten (10) days after the contractor has received notice of the suspension. If no written request for an appeal hearing is received by the Committee within such ten (10) day period, then the decision to suspend will be final and conclusive.
- B. If an appeal hearing is requested, the Contracting Committee will schedule the appeal hearing to be held within ten (10) days after it receives the written request. The Committee will send the contractor written notice by certified mail, return receipt requested, of the time and place of the hearing.
- C. Both SAWS and the contractor will be allowed to request only one postponement of the appeal hearing. Any such request must be in writing and received by the other party at least five days before the originally scheduled date of the appeal hearing. In the event of a postponement, the Contracting Committee will reschedule the appeal hearing to be held within ten (10) days

of the date that the request for postponement was received. The Committee will send the contractor written notice by certified mail, return receipt requested, of the time and place of the rescheduled hearing.

- D. Appeal hearings will be as informal as reasonable and appropriate under the circumstances. Appeal hearings are intended to be a forum for the contractor to express to the Contracting Committee why the contractor should not be suspended and they are not to be adversarial in nature. A verbatim record is not required.
- E. The contractor may be represented by counsel at the appeal hearing.
- F. Within ten (10) days of the appeal hearing, the Contracting Committee will send the contractor written notice by certified mail, return receipt requested, of its final decision on the matter.
- G. If the Contracting Committee upholds the suspension, the contractor may request review of the decision by the President/Chief Executive Officer of SAWS by filing a written request for review with the President/CEO within ten (10) days of the date of the notice of the result of the appeal hearing. The President/CEO will review the material available from the appeal and meet with the contractor and the Committee either separately or jointly as he or she elects. The President/CEO will then send written notice of his/her decision on the suspension by certified mail, return receipt requested, to the contractor within fifteen (15) days of the date of receiving the request for review by the President/CEO.
- H. Only if the contractor has pursued both appeals and the Contracting Committee and the President/CEO have both upheld the suspension may the contractor seek further recourse by filing suit in an appropriate court of law. Any such suit must be filed within 180 days after the contractor has received notice of the President/CEO's final determination upholding the suspension. After such 180 day limitation period has elapsed, the contractor will be barred from seeking recourse in a court of law regarding the suspension. Such 180 day limitation period is necessary for SAWS to effectively administer the contracts to which it is a party. The 180 day limitation period applies only to the contractor's appeal of suspension and will not affect the obligations or rights of any party under a contract with regard to contract obligations and rights.
- I. The suspension and all other relevant provisions herein will remain in effect throughout any appeals process.
- J. For purposes of determining time periods, notices of appeal and requests for review by the President/CEO will be deemed filed when received by SAWS, and notices of decisions will be deemed given when deposited in the U.S.



Mail, certified mail, return receipt requested, addressed to the contractor at the address given on the notice of appeal or the contractor's last contract with SAWS.

## Exhibit C

### SECURITY PROCEDURES

If work will be conducted on SAWS property, on SAWS infrastructure, on a SAWS customer's property, or involve any SAWS networks, or any SAWS facility, the Contractor shall ensure a Prime Contractor Data Form (PCDF) and a "Background Screening Letter" (provided by a third party background screening service) are properly completed for all employees and sub-contractors performing work under this Contract and is on file with SAWS Security prior to work commencement. Background checks must at a minimum include National Criminal Check, Verify Employment Eligibility (E-Verify), and Terrorist Watch List with this information being provided in the Background Screening Letter from the third party screening service. Any person found to have an unacceptable background check will not be allowed to perform work under this Contract (however, at SAWS sole discretion a waiver may be given by SAWS Security for an unacceptable finding provided that it must first be approved and signed off on by the Director of SAWS Security). Any Sub-Contractors performing work must also be listed in the PCDF and the Background Screening Letter. Contractor shall be responsible for the accuracy of information on the PCDF and the Background Screening Letter, and for obtaining any and all required items (badges and parking tags) necessary to fulfilling the work under this Agreement. The PCDF and Background Screening Letter must be sent electronically to [securitygroup@saws.org](mailto:securitygroup@saws.org). Contractor shall advise the SAWS Project Manager/Inspector of any employee terminations or changes to personnel performing work under this Agreement and the Contractor shall immediately turn in any and all badges and/or parking tags of employees who are terminated or no longer performing work under this Contract. If Contractor becomes aware or reasonably should have become aware of any changes in the information contained in the PCDF or the Background Screening Letters, Contractor shall immediately notify the SAWS Project Manager/Inspector and provide updated PCDF and Background Screening Letters, with copies to [securitygroup@saws.org](mailto:securitygroup@saws.org).

Contractor, its employees, and agents shall obtain a SAWS photo identification badge (Contractor's Badge) and parking tag, prior to any work on SAWS property, which shall be used only for purposes necessary to perform the work under this Agreement. SAWS Badge Office hours are Monday, Wednesday and Friday 9:00am to 12:00pm excluding SAWS holidays (hours are subject to change). Security staff can be contacted at (210) 233-3177 or (210) 233-3338. Once the project is completed the Contractor shall return all badges and parking tags to the Security Office. Contractor who does not return the badges or parking tags are not in compliance with these procedures.

SAWS facilities require a SAWS employee to physically escort the Contractor at all times. SAWS may, in its sole discretion, waive the escort requirements if the PCDF and a "clean" Background Screening Letter, signed by an authorized representative of a third party background screening service are approved by the SAWS Project Manager and SAWS Security. Waiver of the escort requirement shall only be through a written correspondence to Contractor from SAWS Security.

Sub-Contractors must always be under escort of Contractor while performing work on any SAWS property or asset. Sub-Contractors must display either a company photo badge, with name, or a valid governmental identification card at all times while working on any SAWS property. The contractor is solely responsible for the actions of its employees, agents, sub-contractors and consultants.

Contractor is responsible for being in compliance with the SAWS security requirements and for maintaining its security of SAWS property, infrastructure, SAWS customer's property, networks, and facilities for the length of the project. Security incidents must be reported to SAWS Security immediately at (210) 233-3338.

If the Contractor plans to stage or store their property such as equipment, storage boxes, tools, trailers or high-priced supplies needed for the project on SAWS Production or Treatment sites the Contractor will be responsible to provide a security guard, who will be subject to SAWS prior approval, when the Contractor is not on the site working.

If the Contractor plans to leave the site unsecure or open during the project they must provide an employee or SAWS approved security guard to monitor ingress and egress to the site. If the Contractor plans to leave the site open or unsecure when not working on the site the Contractor must provide a SAWS approved security guard.

SAWS provides for security on its sites. If Contractor takes any action that diminishes SAWS security, Contractor will be responsible for providing additional security requirements at its expense. Some examples of additional requirements that SAWS may require include hiring of SAWS approved security guards, temporary fencing, mobile Closed Circuit Television Monitoring trailer(s), or extra lighting. Notwithstanding anything herein to the contrary, any provisions in these Security Procedures that may appear to give SAWS the right to direct Contractor as to details of doing any work under this Contract or to exercise a measure of control over any security measures or such work shall be deemed to mean that Contractor shall follow the desires of SAWS in the **results** of the work or security measures only.

Advance coordination by Contractor with SAWS Security for these security requirements is necessary to ensure no delays with timely performance of work. Any other provision of this Contract notwithstanding, in the event Contractor fails to comply with SAWS Security requirements, SAWS may, with no penalty, claim of any nature (including but not limited to breach of contract) against SAWS by the Contractor:

- Issue a Work Stoppage Order until the security violation (s) are remedied
- Ask any unidentified or improperly identified person or equipment to leave SAWS site immediately and not return until items or deficiencies are remedied to SAWS satisfaction.

# Request for Taxpayer Identification Number and Certification

**Give Form to the  
 requester. Do not  
 send to the IRS.**

|   |  |  |
|---|--|--|
| <b>Print or type<br/>See Specific<br/>Instructions on page 2.</b> | <b>1</b> Name (as shown on your income tax return). Name is required on this line; do not leave this line blank.   |  |
|   | <b>2</b> Business name/disregarded entity name, if different from above  |  |
|   | <b>3</b> Check appropriate box for federal tax classification; check only <b>one</b> of the following seven boxes:<br><input type="checkbox"/> Individual/sole proprietor or single-member LLC <input type="checkbox"/> C Corporation <input type="checkbox"/> S Corporation <input type="checkbox"/> Partnership <input type="checkbox"/> Trust/estate<br><input type="checkbox"/> Limited liability company. Enter the tax classification (C=C corporation, S=S corporation, P=partnership) ▶ _____<br><b>Note.</b> For a single-member LLC that is disregarded, do not check LLC; check the appropriate box in the line above for the tax classification of the single-member owner.<br><input type="checkbox"/> Other (see instructions) ▶ _____ | <b>4</b> Exemptions (codes apply only to certain entities, not individuals; see instructions on page 3):<br>Exempt payee code (if any) _____<br>Exemption from FATCA reporting code (if any) _____<br><i>(Applies to accounts maintained outside the U.S.)</i> |
|   | <b>5</b> Address (number, street, and apt. or suite no.)   | Requester's name and address (optional)  |
|   | <b>6</b> City, state, and ZIP code   |  |
|   | <b>7</b> List account number(s) here (optional)  |  |

## Part I Taxpayer Identification Number (TIN)

Enter your TIN in the appropriate box. The TIN provided must match the name given on line 1 to avoid backup withholding. For individuals, this is generally your social security number (SSN). However, for a resident alien, sole proprietor, or disregarded entity, see the Part I instructions on page 3. For other entities, it is your employer identification number (EIN). If you do not have a number, see *How to get a TIN* on page 3.

|                                       |  |  |  |   |  |  |   |  |  |
|---------------------------------------|--|--|--|---|--|--|---|--|--|
| <b>Social security number</b>         |  |  |  |   |  |  |   |  |  |
|                                       |  |  |  | - |  |  | - |  |  |
| <b>or</b>                             |  |  |  |   |  |  |   |  |  |
| <b>Employer identification number</b> |  |  |  |   |  |  |   |  |  |
|                                       |  |  |  | - |  |  |   |  |  |

**Note.** If the account is in more than one name, see the instructions for line 1 and the chart on page 4 for guidelines on whose number to enter.

## Part II Certification

Under penalties of perjury, I certify that:

1. The number shown on this form is my correct taxpayer identification number (or I am waiting for a number to be issued to me); and
2. I am not subject to backup withholding because: (a) I am exempt from backup withholding, or (b) I have not been notified by the Internal Revenue Service (IRS) that I am subject to backup withholding as a result of a failure to report all interest or dividends, or (c) the IRS has notified me that I am no longer subject to backup withholding; and
3. I am a U.S. citizen or other U.S. person (defined below); and
4. The FATCA code(s) entered on this form (if any) indicating that I am exempt from FATCA reporting is correct.

**Certification instructions.** You must cross out item 2 above if you have been notified by the IRS that you are currently subject to backup withholding because you have failed to report all interest and dividends on your tax return. For real estate transactions, item 2 does not apply. For mortgage interest paid, acquisition or abandonment of secured property, cancellation of debt, contributions to an individual retirement arrangement (IRA), and generally, payments other than interest and dividends, you are not required to sign the certification, but you must provide your correct TIN. See the instructions on page 3.

|                  |                            |        |
|------------------|----------------------------|--------|
| <b>Sign Here</b> | Signature of U.S. person ▶ | Date ▶ |
|------------------|----------------------------|--------|

## General Instructions

Section references are to the Internal Revenue Code unless otherwise noted.

**Future developments.** Information about developments affecting Form W-9 (such as legislation enacted after we release it) is at [www.irs.gov/fw9](http://www.irs.gov/fw9).

### Purpose of Form

An individual or entity (Form W-9 requester) who is required to file an information return with the IRS must obtain your correct taxpayer identification number (TIN) which may be your social security number (SSN), individual taxpayer identification number (ITIN), adoption taxpayer identification number (ATIN), or employer identification number (EIN), to report on an information return the amount paid to you, or other amount reportable on an information return. Examples of information returns include, but are not limited to, the following:

- Form 1099-INT (interest earned or paid)
- Form 1099-DIV (dividends, including those from stocks or mutual funds)
- Form 1099-MISC (various types of income, prizes, awards, or gross proceeds)
- Form 1099-B (stock or mutual fund sales and certain other transactions by brokers)
- Form 1099-S (proceeds from real estate transactions)
- Form 1099-K (merchant card and third party network transactions)

- Form 1098 (home mortgage interest), 1098-E (student loan interest), 1098-T (tuition)
- Form 1099-C (canceled debt)
- Form 1099-A (acquisition or abandonment of secured property)

Use Form W-9 only if you are a U.S. person (including a resident alien), to provide your correct TIN.

*If you do not return Form W-9 to the requester with a TIN, you might be subject to backup withholding. See What is backup withholding? on page 2.*

By signing the filled-out form, you:

1. Certify that the TIN you are giving is correct (or you are waiting for a number to be issued),
2. Certify that you are not subject to backup withholding, or
3. Claim exemption from backup withholding if you are a U.S. exempt payee. If applicable, you are also certifying that as a U.S. person, your allocable share of any partnership income from a U.S. trade or business is not subject to the withholding tax on foreign partners' share of effectively connected income, and
4. Certify that FATCA code(s) entered on this form (if any) indicating that you are exempt from the FATCA reporting, is correct. See *What is FATCA reporting?* on page 2 for further information.

**Note.** If you are a U.S. person and a requester gives you a form other than Form W-9 to request your TIN, you must use the requester's form if it is substantially similar to this Form W-9.

**Definition of a U.S. person.** For federal tax purposes, you are considered a U.S. person if you are:

- An individual who is a U.S. citizen or U.S. resident alien;
- A partnership, corporation, company, or association created or organized in the United States or under the laws of the United States;
- An estate (other than a foreign estate); or
- A domestic trust (as defined in Regulations section 301.7701-7).

**Special rules for partnerships.** Partnerships that conduct a trade or business in the United States are generally required to pay a withholding tax under section 1446 on any foreign partners' share of effectively connected taxable income from such business. Further, in certain cases where a Form W-9 has not been received, the rules under section 1446 require a partnership to presume that a partner is a foreign person, and pay the section 1446 withholding tax. Therefore, if you are a U.S. person that is a partner in a partnership conducting a trade or business in the United States, provide Form W-9 to the partnership to establish your U.S. status and avoid section 1446 withholding on your share of partnership income.

In the cases below, the following person must give Form W-9 to the partnership for purposes of establishing its U.S. status and avoiding withholding on its allocable share of net income from the partnership conducting a trade or business in the United States:

- In the case of a disregarded entity with a U.S. owner, the U.S. owner of the disregarded entity and not the entity;
- In the case of a grantor trust with a U.S. grantor or other U.S. owner, generally, the U.S. grantor or other U.S. owner of the grantor trust and not the trust; and
- In the case of a U.S. trust (other than a grantor trust), the U.S. trust (other than a grantor trust) and not the beneficiaries of the trust.

**Foreign person.** If you are a foreign person or the U.S. branch of a foreign bank that has elected to be treated as a U.S. person, do not use Form W-9. Instead, use the appropriate Form W-8 or Form 8233 (see Publication 515, Withholding of Tax on Nonresident Aliens and Foreign Entities).

**Nonresident alien who becomes a resident alien.** Generally, only a nonresident alien individual may use the terms of a tax treaty to reduce or eliminate U.S. tax on certain types of income. However, most tax treaties contain a provision known as a "saving clause." Exceptions specified in the saving clause may permit an exemption from tax to continue for certain types of income even after the payee has otherwise become a U.S. resident alien for tax purposes.

If you are a U.S. resident alien who is relying on an exception contained in the saving clause of a tax treaty to claim an exemption from U.S. tax on certain types of income, you must attach a statement to Form W-9 that specifies the following five items:

1. The treaty country. Generally, this must be the same treaty under which you claimed exemption from tax as a nonresident alien.
2. The treaty article addressing the income.
3. The article number (or location) in the tax treaty that contains the saving clause and its exceptions.
4. The type and amount of income that qualifies for the exemption from tax.
5. Sufficient facts to justify the exemption from tax under the terms of the treaty article.

**Example.** Article 20 of the U.S.-China income tax treaty allows an exemption from tax for scholarship income received by a Chinese student temporarily present in the United States. Under U.S. law, this student will become a resident alien for tax purposes if his or her stay in the United States exceeds 5 calendar years. However, paragraph 2 of the first Protocol to the U.S.-China treaty (dated April 30, 1984) allows the provisions of Article 20 to continue to apply even after the Chinese student becomes a resident alien of the United States. A Chinese student who qualifies for this exception (under paragraph 2 of the first protocol) and is relying on this exception to claim an exemption from tax on his or her scholarship or fellowship income would attach to Form W-9 a statement that includes the information described above to support that exemption.

If you are a nonresident alien or a foreign entity, give the requester the appropriate completed Form W-8 or Form 8233.

## Backup Withholding

**What is backup withholding?** Persons making certain payments to you must under certain conditions withhold and pay to the IRS 28% of such payments. This is called "backup withholding." Payments that may be subject to backup withholding include interest, tax-exempt interest, dividends, broker and barter exchange transactions, rents, royalties, nonemployee pay, payments made in settlement of payment card and third party network transactions, and certain payments from fishing boat operators. Real estate transactions are not subject to backup withholding.

You will not be subject to backup withholding on payments you receive if you give the requester your correct TIN, make the proper certifications, and report all your taxable interest and dividends on your tax return.

**Payments you receive will be subject to backup withholding if:**

1. You do not furnish your TIN to the requester,
2. You do not certify your TIN when required (see the Part II instructions on page 3 for details),

3. The IRS tells the requester that you furnished an incorrect TIN,

4. The IRS tells you that you are subject to backup withholding because you did not report all your interest and dividends on your tax return (for reportable interest and dividends only), or

5. You do not certify to the requester that you are not subject to backup withholding under 4 above (for reportable interest and dividend accounts opened after 1983 only).

Certain payees and payments are exempt from backup withholding. See *Exempt payee code* on page 3 and the separate Instructions for the Requester of Form W-9 for more information.

Also see *Special rules for partnerships* above.

## What is FATCA reporting?

The Foreign Account Tax Compliance Act (FATCA) requires a participating foreign financial institution to report all United States account holders that are specified United States persons. Certain payees are exempt from FATCA reporting. See *Exemption from FATCA reporting code* on page 3 and the Instructions for the Requester of Form W-9 for more information.

## Updating Your Information

You must provide updated information to any person to whom you claimed to be an exempt payee if you are no longer an exempt payee and anticipate receiving reportable payments in the future from this person. For example, you may need to provide updated information if you are a C corporation that elects to be an S corporation, or if you no longer are tax exempt. In addition, you must furnish a new Form W-9 if the name or TIN changes for the account; for example, if the grantor of a grantor trust dies.

## Penalties

**Failure to furnish TIN.** If you fail to furnish your correct TIN to a requester, you are subject to a penalty of \$50 for each such failure unless your failure is due to reasonable cause and not to willful neglect.

**Civil penalty for false information with respect to withholding.** If you make a false statement with no reasonable basis that results in no backup withholding, you are subject to a \$500 penalty.

**Criminal penalty for falsifying information.** Willfully falsifying certifications or affirmations may subject you to criminal penalties including fines and/or imprisonment.

**Misuse of TINs.** If the requester discloses or uses TINs in violation of federal law, the requester may be subject to civil and criminal penalties.

## Specific Instructions

### Line 1

You must enter one of the following on this line; **do not** leave this line blank. The name should match the name on your tax return.

If this Form W-9 is for a joint account, list first, and then circle, the name of the person or entity whose number you entered in Part I of Form W-9.

a. **Individual.** Generally, enter the name shown on your tax return. If you have changed your last name without informing the Social Security Administration (SSA) of the name change, enter your first name, the last name as shown on your social security card, and your new last name.

**Note. ITIN applicant:** Enter your individual name as it was entered on your Form W-7 application, line 1a. This should also be the same as the name you entered on the Form 1040/1040A/1040EZ you filed with your application.

b. **Sole proprietor or single-member LLC.** Enter your individual name as shown on your 1040/1040A/1040EZ on line 1. You may enter your business, trade, or "doing business as" (DBA) name on line 2.

c. **Partnership, LLC that is not a single-member LLC, C Corporation, or S Corporation.** Enter the entity's name as shown on the entity's tax return on line 1 and any business, trade, or DBA name on line 2.

d. **Other entities.** Enter your name as shown on required U.S. federal tax documents on line 1. This name should match the name shown on the charter or other legal document creating the entity. You may enter any business, trade, or DBA name on line 2.

e. **Disregarded entity.** For U.S. federal tax purposes, an entity that is disregarded as an entity separate from its owner is treated as a "disregarded entity." See Regulations section 301.7701-2(c)(2)(iii). Enter the owner's name on line 1. The name of the entity entered on line 1 should never be a disregarded entity. The name on line 1 should be the name shown on the income tax return on which the income should be reported. For example, if a foreign LLC that is treated as a disregarded entity for U.S. federal tax purposes has a single owner that is a U.S. person, the U.S. owner's name is required to be provided on line 1. If the direct owner of the entity is also a disregarded entity, enter the first owner that is not disregarded for federal tax purposes. Enter the disregarded entity's name on line 2, "Business name/disregarded entity name." If the owner of the disregarded entity is a foreign person, the owner must complete an appropriate Form W-8 instead of a Form W-9. This is the case even if the foreign person has a U.S. TIN.

**Line 2**

If you have a business name, trade name, DBA name, or disregarded entity name, you may enter it on line 2.

**Line 3**

Check the appropriate box in line 3 for the U.S. federal tax classification of the person whose name is entered on line 1. Check only one box in line 3.

**Limited Liability Company (LLC).** If the name on line 1 is an LLC treated as a partnership for U.S. federal tax purposes, check the "Limited Liability Company" box and enter "P" in the space provided. If the LLC has filed Form 8832 or 2553 to be taxed as a corporation, check the "Limited Liability Company" box and in the space provided enter "C" for C corporation or "S" for S corporation. If it is a single-member LLC that is a disregarded entity, do not check the "Limited Liability Company" box; instead check the first box in line 3 "Individual/sole proprietor or single-member LLC."

**Line 4, Exemptions**

If you are exempt from backup withholding and/or FATCA reporting, enter in the appropriate space in line 4 any code(s) that may apply to you.

**Exempt payee code.**

- Generally, individuals (including sole proprietors) are not exempt from backup withholding.
- Except as provided below, corporations are exempt from backup withholding for certain payments, including interest and dividends.
- Corporations are not exempt from backup withholding for payments made in settlement of payment card or third party network transactions.
- Corporations are not exempt from backup withholding with respect to attorneys' fees or gross proceeds paid to attorneys, and corporations that provide medical or health care services are not exempt with respect to payments reportable on Form 1099-MISC.

The following codes identify payees that are exempt from backup withholding. Enter the appropriate code in the space in line 4.

- 1—An organization exempt from tax under section 501(a), any IRA, or a custodial account under section 403(b)(7) if the account satisfies the requirements of section 401(f)(2)
- 2—The United States or any of its agencies or instrumentalities
- 3—A state, the District of Columbia, a U.S. commonwealth or possession, or any of their political subdivisions or instrumentalities
- 4—A foreign government or any of its political subdivisions, agencies, or instrumentalities
- 5—A corporation
- 6—A dealer in securities or commodities required to register in the United States, the District of Columbia, or a U.S. commonwealth or possession
- 7—A futures commission merchant registered with the Commodity Futures Trading Commission
- 8—A real estate investment trust
- 9—An entity registered at all times during the tax year under the Investment Company Act of 1940
- 10—A common trust fund operated by a bank under section 584(a)
- 11—A financial institution
- 12—A middleman known in the investment community as a nominee or custodian
- 13—A trust exempt from tax under section 664 or described in section 4947

The following chart shows types of payments that may be exempt from backup withholding. The chart applies to the exempt payees listed above, 1 through 13.

| IF the payment is for . . .  | THEN the payment is exempt for . . .  |
|--|---|
| Interest and dividend payments   | All exempt payees except for 7  |
| Broker transactions  | Exempt payees 1 through 4 and 6 through 11 and all C corporations. S corporations must not enter an exempt payee code because they are exempt only for sales of noncovered securities acquired prior to 2012. |
| Barter exchange transactions and patronage dividends                                   | Exempt payees 1 through 4   |
| Payments over \$600 required to be reported and direct sales over \$5,000 <sup>1</sup> | Generally, exempt payees 1 through 5 <sup>2</sup>   |
| Payments made in settlement of payment card or third party network transactions        | Exempt payees 1 through 4   |

<sup>1</sup> See Form 1099-MISC, Miscellaneous Income, and its instructions.

<sup>2</sup> However, the following payments made to a corporation and reportable on Form 1099-MISC are not exempt from backup withholding: medical and health care payments, attorneys' fees, gross proceeds paid to an attorney reportable under section 6045(f), and payments for services paid by a federal executive agency.

**Exemption from FATCA reporting code.** The following codes identify payees that are exempt from reporting under FATCA. These codes apply to persons submitting this form for accounts maintained outside of the United States by certain foreign financial institutions. Therefore, if you are only submitting this form for an account you hold in the United States, you may leave this field blank. Consult with the person requesting this form if you are uncertain if the financial institution is subject to these requirements. A requester may indicate that a code is not required by providing you with a Form W-9 with "Not Applicable" (or any similar indication) written or printed on the line for a FATCA exemption code.

A—An organization exempt from tax under section 501(a) or any individual retirement plan as defined in section 7701(a)(37)

B—The United States or any of its agencies or instrumentalities

C—A state, the District of Columbia, a U.S. commonwealth or possession, or any of their political subdivisions or instrumentalities

D—A corporation the stock of which is regularly traded on one or more established securities markets, as described in Regulations section 1.1472-1(c)(1)(i)

E—A corporation that is a member of the same expanded affiliated group as a corporation described in Regulations section 1.1472-1(c)(1)(i)

F—A dealer in securities, commodities, or derivative financial instruments (including notional principal contracts, futures, forwards, and options) that is registered as such under the laws of the United States or any state

G—A real estate investment trust

H—A regulated investment company as defined in section 851 or an entity registered at all times during the tax year under the Investment Company Act of 1940

I—A common trust fund as defined in section 584(a)

J—A bank as defined in section 581

K—A broker

L—A trust exempt from tax under section 664 or described in section 4947(a)(1)

M—A tax exempt trust under a section 403(b) plan or section 457(g) plan

**Note.** You may wish to consult with the financial institution requesting this form to determine whether the FATCA code and/or exempt payee code should be completed.

**Line 5**

Enter your address (number, street, and apartment or suite number). This is where the requester of this Form W-9 will mail your information returns.

**Line 6**

Enter your city, state, and ZIP code.

**Part I. Taxpayer Identification Number (TIN)**

**Enter your TIN in the appropriate box.** If you are a resident alien and you do not have and are not eligible to get an SSN, your TIN is your IRS individual taxpayer identification number (ITIN). Enter it in the social security number box. If you do not have an ITIN, see *How to get a TIN* below.

If you are a sole proprietor and you have an EIN, you may enter either your SSN or EIN. However, the IRS prefers that you use your SSN.

If you are a single-member LLC that is disregarded as an entity separate from its owner (see *Limited Liability Company (LLC)* on this page), enter the owner's SSN (or EIN, if the owner has one). Do not enter the disregarded entity's EIN. If the LLC is classified as a corporation or partnership, enter the entity's EIN.

**Note.** See the chart on page 4 for further clarification of name and TIN combinations.

**How to get a TIN.** If you do not have a TIN, apply for one immediately. To apply for an SSN, get Form SS-5, Application for a Social Security Card, from your local SSA office or get this form online at [www.ssa.gov](http://www.ssa.gov). You may also get this form by calling 1-800-772-1213. Use Form W-7, Application for IRS Individual Taxpayer Identification Number, to apply for an ITIN, or Form SS-4, Application for Employer Identification Number, to apply for an EIN. You can apply for an EIN online by accessing the IRS website at [www.irs.gov/businesses](http://www.irs.gov/businesses) and clicking on Employer Identification Number (EIN) under Starting a Business. You can get Forms W-7 and SS-4 from the IRS by visiting [IRS.gov](http://IRS.gov) or by calling 1-800-TAX-FORM (1-800-829-3676).

If you are asked to complete Form W-9 but do not have a TIN, apply for a TIN and write "Applied For" in the space for the TIN, sign and date the form, and give it to the requester. For interest and dividend payments, and certain payments made with respect to readily tradable instruments, generally you will have 60 days to get a TIN and give it to the requester before you are subject to backup withholding on payments. The 60-day rule does not apply to other types of payments. You will be subject to backup withholding on all such payments until you provide your TIN to the requester.

**Note.** Entering "Applied For" means that you have already applied for a TIN or that you intend to apply for one soon.

**Caution:** A disregarded U.S. entity that has a foreign owner must use the

**Part II. Certification**

To establish to the withholding agent that you are a U.S. person, or resident alien, sign Form W-9. You may be requested to sign by the withholding agent even if items 1, 4, or 5 below indicate otherwise.

For a joint account, only the person whose TIN is shown in Part I should sign (when required). In the case of a disregarded entity, the person identified on line 1 must sign. Exempt payees, see *Exempt payee code* earlier.

**Signature requirements.** Complete the certification as indicated in items 1 through 5 below.

**1. Interest, dividend, and barter exchange accounts opened before 1984 and broker accounts considered active during 1983.** You must give your correct TIN, but you do not have to sign the certification.

**2. Interest, dividend, broker, and barter exchange accounts opened after 1983 and broker accounts considered inactive during 1983.** You must sign the certification or backup withholding will apply. If you are subject to backup withholding and you are merely providing your correct TIN to the requester, you must cross out item 2 in the certification before signing the form.

**3. Real estate transactions.** You must sign the certification. You may cross out item 2 of the certification.

**4. Other payments.** You must give your correct TIN, but you do not have to sign the certification unless you have been notified that you have previously given an incorrect TIN. "Other payments" include payments made in the course of the requester's trade or business for rents, royalties, goods (other than bills for merchandise), medical and health care services (including payments to corporations), payments to a nonemployee for services, payments made in settlement of payment card and third party network transactions, payments to certain fishing boat crew members and fishermen, and gross proceeds paid to attorneys (including payments to corporations).

**5. Mortgage interest paid by you, acquisition or abandonment of secured property, cancellation of debt, qualified tuition program payments (under section 529), IRA, Coverdell ESA, Archer MSA or HSA contributions or distributions, and pension distributions.** You must give your correct TIN, but you do not have to sign the certification.

**What Name and Number To Give the Requester**

| For this type of account:   | Give name and SSN of:   |
|---|---|
| 1. Individual   | The individual  |
| 2. Two or more individuals (joint account)  | The actual owner of the account or, if combined funds, the first individual on the account <sup>1</sup> |
| 3. Custodian account of a minor (Uniform Gift to Minors Act)  | The minor <sup>2</sup>  |
| 4. a. The usual revocable savings trust (grantor is also trustee)<br>b. So-called trust account that is not a legal or valid trust under state law  | The grantor-trustee <sup>1</sup><br><br>The actual owner <sup>1</sup>                                   |
| 5. Sole proprietorship or disregarded entity owned by an individual   | The owner <sup>3</sup>  |
| 6. Grantor trust filing under Optional Form 1099 Filing Method 1 (see Regulations section 1.671-4(b)(2)(i)(A))  | The grantor*  |
| For this type of account:   | Give name and EIN of:   |
| 7. Disregarded entity not owned by an individual  | The owner   |
| 8. A valid trust, estate, or pension trust  | Legal entity <sup>4</sup>   |
| 9. Corporation or LLC electing corporate status on Form 8832 or Form 2553   | The corporation   |
| 10. Association, club, religious, charitable, educational, or other tax-exempt organization   | The organization  |
| 11. Partnership or multi-member LLC   | The partnership   |
| 12. A broker or registered nominee  | The broker or nominee   |
| 13. Account with the Department of Agriculture in the name of a public entity (such as a state or local government, school district, or prison) that receives agricultural program payments | The public entity   |
| 14. Grantor trust filing under the Form 1041 Filing Method or the Optional Form 1099 Filing Method 2 (see Regulations section 1.671-4(b)(2)(i)(B))  | The trust   |

<sup>1</sup> List first and circle the name of the person whose number you furnish. If only one person on a joint account has an SSN, that person's number must be furnished.

<sup>2</sup> Circle the minor's name and furnish the minor's SSN.

<sup>3</sup> You must show your individual name and you may also enter your business or DBA name on the "Business name/disregarded entity" name line. You may use either your SSN or EIN (if you have one), but the IRS encourages you to use your SSN.

<sup>4</sup> List first and circle the name of the trust, estate, or pension trust. (Do not furnish the TIN of the personal representative or trustee unless the legal entity itself is not designated in the account title.) Also see *Special rules for partnerships* on page 2.

\*Note. Grantor also must provide a Form W-9 to trustee of trust.

**Note.** If no name is circled when more than one name is listed, the number will be considered to be that of the first name listed.

**Secure Your Tax Records from Identity Theft**

Identity theft occurs when someone uses your personal information such as your name, SSN, or other identifying information, without your permission, to commit fraud or other crimes. An identity thief may use your SSN to get a job or may file a tax return using your SSN to receive a refund.

To reduce your risk:

- Protect your SSN,
- Ensure your employer is protecting your SSN, and
- Be careful when choosing a tax preparer.

If your tax records are affected by identity theft and you receive a notice from the IRS, respond right away to the name and phone number printed on the IRS notice or letter.

If your tax records are not currently affected by identity theft but you think you are at risk due to a lost or stolen purse or wallet, questionable credit card activity or credit report, contact the IRS Identity Theft Hotline at 1-800-908-4490 or submit Form 14039.

For more information, see Publication 4535, Identity Theft Prevention and Victim Assistance.

Victims of identity theft who are experiencing economic harm or a system problem, or are seeking help in resolving tax problems that have not been resolved through normal channels, may be eligible for Taxpayer Advocate Service (TAS) assistance. You can reach TAS by calling the TAS toll-free case intake line at 1-877-777-4778 or TTY/TDD 1-800-829-4059.

**Protect yourself from suspicious emails or phishing schemes.** Phishing is the creation and use of email and websites designed to mimic legitimate business emails and websites. The most common act is sending an email to a user falsely claiming to be an established legitimate enterprise in an attempt to scam the user into surrendering private information that will be used for identity theft.

The IRS does not initiate contacts with taxpayers via emails. Also, the IRS does not request personal detailed information through email or ask taxpayers for the PIN numbers, passwords, or similar secret access information for their credit card, bank, or other financial accounts.

If you receive an unsolicited email claiming to be from the IRS, forward this message to [phishing@irs.gov](mailto:phishing@irs.gov). You may also report misuse of the IRS name, logo, or other IRS property to the Treasury Inspector General for Tax Administration (TIGTA) at 1-800-366-4484. You can forward suspicious emails to the Federal Trade Commission at: [spam@uce.gov](mailto:spam@uce.gov) or contact them at [www.ftc.gov/idtheft](http://www.ftc.gov/idtheft) or 1-877-IDTHEFT (1-877-438-4338).

Visit [IRS.gov](http://IRS.gov) to learn more about identity theft and how to reduce your risk.

**Privacy Act Notice**

Section 6109 of the Internal Revenue Code requires you to provide your correct TIN to persons (including federal agencies) who are required to file information returns with the IRS to report interest, dividends, or certain other income paid to you; mortgage interest you paid; the acquisition or abandonment of secured property; the cancellation of debt; or contributions you made to an IRA, Archer MSA, or HSA. The person collecting this form uses the information on the form to file information returns with the IRS, reporting the above information. Routine uses of this information include giving it to the Department of Justice for civil and criminal litigation and to cities, states, the District of Columbia, and U.S. commonwealths and possessions for use in administering their laws. The information also may be disclosed to other countries under a treaty, to federal and state agencies to enforce civil and criminal laws, or to federal law enforcement and intelligence agencies to combat terrorism. You must provide your TIN whether or not you are required to file a tax return. Under section 3406, payers must generally withhold a percentage of taxable interest, dividend, and certain other payments to a payee who does not give a TIN to the payer. Certain penalties may also apply for providing false or fraudulent information.

**Instructions for Completing the ACORD  
Certificate of Liability Insurance**  
(Form – ACORD 25 [Version: 2016/03])

1. **DATE (MM/DD/YYYY)** – this is the date the Certificate is generated;
  
2. **PRODUCER** – insert the complete name and address of the insurance agency or broker issuing this Certificate; in the adjacent cell (located just to the right of the PRODUCER cell) include CONTACT PERSON’s name, office phone, Fax number(s) and e-mail address.
  
3. **INSURED** – enter the complete legal name and address of the Consulting Firm, the Contractor’s Company or the Supplier’s Company (to include any dba used);

**4. INSURERS AFFORDING COVERAGE**

- a. **INSURER A** through **E** – enter the insurance carrier’s complete Operating Company name; **or**
- b. **NAIC #** - enter National Association of Insurance Commissioners (5 – digit) insurance carrier ID number.

**NOTE:**

If the name of the Insurer used cannot be located in the A.M. Best Directory, then the NAIC # will be required.

**5. CERTIFICATE NUMBER/REVISION NUMBER**

These two data fields, if utilized by the insurance agency or insurance broker, could be used as a quick reference number; SAWS does not require this to be used.

**6. COVERAGES**

- a. **INSURER Letter (INSR/LTR)** column - place the corresponding letter of the insurance carrier affording coverage by each respective type of insurance coverage;
  
- b. **TYPE OF INSURANCE:**
  - 1) **GENERAL LIABILITY:**
    - a) **COMMERCIAL GENERAL LIABILITY** – place an “X” in the space provided;
  
    - b) **OCCUR** (Occurrence based form) - place an “X” in the space provided;



**Instructions for Completing the ACORD  
Certificate of Liability Insurance  
(Form – ACORD 25 [Version: 2016/03])**

c) **GEN'L AGGREGATE LIMIT APPLIES PER:**

- For *Construction Contracts* - place an "X" in the box right in front of the word **PROJECT**; or
- For all *Other Contracts* - an "X" in the box right in front of either the word **POLICY** or **LOCATION** is acceptable.

d) **ADDL INSR and SUBR WVD** columns:

The two columns labeled **ADDL INSR** and **SUBR WVD** are provided to indicate by a check mark or an "X" whether this line of insurance coverage is endorsed with both the Additional Insured and the Waiver of Subrogation.

The use of these two columns **alone** does not meet SAWS Insurance Specifications.

SAWS requires the following specific endorsement wording for the Additional Insured and Waiver of Subrogation endorsements, to be inserted into the **DESCRIPTION OF OPERATIONS** section of the Certificate:

**Additional Insured:**

*Either use:*

"The Automobile Liability, **Commercial General Liability** and Umbrella Liability policies include a blanket automatic Additional Insured endorsement that provides additional insured status to the Certificate Holder (SAWS) and the City of San Antonio only when there is a written contract between the named Insured and the Certificate Holder that requires such status."

*Or use:*

"The Automobile Liability, **Commercial General Liability** and Umbrella Liability policies are endorsed naming the San Antonio Water System and the City of San Antonio as an Additional Insured."

**Waiver of Subrogation:**

*Either use:*

The Automobile Liability, **Commercial General Liability** and Workers' Compensation and Umbrella Liability policies include a blanket, automatic Waiver of Subrogation endorsement that provides this feature only when there is a written contract between the named Insured, the Certificate Holder (SAWS) and the City of

**Instructions for Completing the ACORD  
Certificate of Liability Insurance  
(Form – ACORD 25 [Version: 2016/03])**

San Antonio that requires such status.

***Or use:***

“The Automobile Liability, **Commercial General Liability**, Workers’ Compensation and Umbrella Liability policies are endorsed with the Waiver of Subrogation in favor of the San Antonio Water System and the City of San Antonio.”

- e) Enter complete **POLICY NUMBER, POLICY EFFECTIVE DATE (MM/DD/YYYY)**, and **POLICY EXPIRATION DATE (MM/DD/YYYY)**;
- f) The minimum policy **LIMITS** for the Commercial General Liability coverage are as follows:

|                 |   |
|-----------------|---|
| \$ 1,000,000.00 | Occurrence Limit  |
| 2,000,000.00    | General Aggregate   |
| 1,000,000.00    | Products/Completed Operations Aggregate (See <b>NOTE</b> below) |
| 1,000,000.00    | Personal and Advertising Injury                                 |

**NOTE:**

The above limits for Products/Completed Operations Aggregate for all Construction Contracts is \$2 million.

2) **AUTOMOBILE LIABILITY:**

- a) Place an “X” in the box in front of each appropriate auto category for which coverage applies.
- b) **ADDL INSR and SUBR WVD** columns:

The two columns labeled **ADDL INSR** and **SUBR WVD** are provided to indicate by a check mark or an “X” whether this line of insurance coverage is endorsed with both the Additional Insured and the Waiver of Subrogation.

The use of these two columns **alone** does not meet SAWS Insurance Specifications.

SAWS requires the following specific endorsement wording for the Additional Insured and Waiver of Subrogation endorsements, to be inserted into the **DESCRIPTION OF OPERATIONS** section of the Certificate:

**Additional Insured:**

***Either use:***

**Instructions for Completing the ACORD  
Certificate of Liability Insurance  
(Form – ACORD 25 [Version: 2016/03])**

“The **Automobile Liability**, Commercial General Liability and Umbrella Liability policies include a blanket automatic Additional Insured endorsement that provides additional insured status to the Certificate Holder (SAWS) and the City of San Antonio only when there is a written contract between the named Insured and the Certificate Holder that requires such status.”

***Or use:***

“The **Automobile Liability**, Commercial General Liability and Umbrella Liability policies are endorsed naming the San Antonio Water System and the City of San Antonio as an Additional Insured.”

**Waiver of Subrogation:**

***Either use:***

The **Automobile Liability**, Commercial General Liability and Workers’ Compensation and Umbrella Liability policies include a blanket, automatic Waiver of Subrogation endorsement that provides this feature only when there is a written contract between the named Insured, the Certificate Holder (SAWS) and the City of San Antonio that requires such status.

***Or use:***

“The **Automobile Liability**, Commercial General Liability, Workers’ Compensation and Umbrella Liability policies are endorsed with the Waiver of Subrogation in favor of the San Antonio Water System and the City of San Antonio.”

- c) Enter complete **POLICY NUMBER, POLICY EFFECTIVE DATE (MM/DD/YYYY)**, and **POLICY EXPIRATION DATE (MM/DD/YYYY)**.
- d) The typical minimum limits of liability for bodily injury and property damage **combined** for this line of insurance coverage shall be not less than \$1,000,000.00 each accident.

**NOTE:**

If the Contractor’s Pollution Liability policy is required and the Contractor’s Pollution Liability policy **is not endorsed** to provide transportation coverage beyond the boundaries of the job site the Commercial/Business Automobile Liability policy must have the CA9948 endorsement (“**Pollution Liability – Broadened Coverage for Covered Autos – Business Auto, Motor Carrier and Truckers Coverage**” forms) - the following statement noting this endorsement shall be placed either in the blank area just below the **NON OWNED AUTOS** wording on the Certificate **or** in the **DESCRIPTION OF OPERATIONS** section of the Certificate:

**Instructions for Completing the ACORD  
Certificate of Liability Insurance  
(Form – ACORD 25 [Version: 2016/03])**

*“Contractor’s Commercial/Business Automobile Liability insurance coverage is endorsed with the CA9948 endorsement to provide transportation coverage beyond the boundaries of the job site.”*

Policy must also be endorsed with MCS90 endorsement when hazardous material(s) are being transported.

3) **EXCESS/UMBRELLA LIABILITY** (where applicable):

- a) Coverage form used - place an “X” in the appropriate box that identifies the coverage form under which this Policy is written: **UMBRELLA LIAB** or **EXCESS LIAB**; and
- b) Occurrence or Claims-Made basis - SAWS requires an “X” be placed in the box right in front of the word **OCCUR**;
- c) **ADDL INSR and SUBR WVD** columns:

The two columns labeled **ADDL INSR** and **SUBR WVD** are provided to indicate by a check mark or an “X” whether this line of insurance coverage is endorsed with both the Additional Insured and the Waiver of Subrogation.

The use of these two columns **alone** does not meet SAWS Insurance Specifications.

SAWS requires the following specific endorsement wording for the Additional Insured and Waiver of Subrogation endorsements, to be inserted into the **DESCRIPTION OF OPERATIONS** section of the Certificate:

**Additional Insured:**

***Either use:***

“The Automobile Liability, Commercial General Liability and **Umbrella Liability** policies include a blanket automatic Additional Insured endorsement that provides additional insured status to the Certificate Holder (SAWS) and the City of San Antonio only when there is a written contract between the named Insured and the Certificate Holder that requires such status.”

***Or use:***

“The Automobile Liability, Commercial General Liability and **Umbrella Liability** policies are endorsed naming the San Antonio Water System and the City of San Antonio as an Additional Insured.”

**Instructions for Completing the ACORD  
Certificate of Liability Insurance  
(Form – ACORD 25 [Version: 2016/03])**

**Waiver of Subrogation:**

*Either use:*

The Automobile Liability, Commercial General Liability and Workers' Compensation and **Umbrella Liability** policies include a blanket, automatic Waiver of Subrogation endorsement that provides this feature only when there is a written contract between the named Insured, the Certificate Holder (SAWS) and the City of San Antonio that requires such status.

*Or use:*

“The Automobile Liability, Commercial General Liability, Workers' Compensation and **Umbrella Liability** policies are endorsed with the Waiver of Subrogation in favor of the San Antonio Water System and the City of San Antonio.”

d) Enter complete **POLICY NUMBER, POLICY EFFECTIVE DATE (MM/DD/YYYY),** and **POLICY EXPIRATION DATE (MM/DD/YYYY).**

e) The minimum limits\* of liability for this line of insurance coverage shall be:

|                     |                          |
|---------------------|--------------------------|
| \$ 2,000,000.00     | Occurrence Limit         |
| <u>2,000,000.00</u> | <u>General Aggregate</u> |

\*The above limits may vary from \$5 million to \$50 million depending on the degree of and potential for greater liability exposure to SAWS. Check the General Conditions – Special Conditions section of the Bid document for the increased coverage limits.

4) **WORKERS' COMPENSATION AND EMPLOYER'S LIABILITY:**

a) Answer the Question: ANY PROPRIETOR/PARTNER/EXECUTIVE OFFICER/MEMBER EXCLUDED? If yes, describe under SPECIAL PROVISIONS below.

b) **ADDL INSR and SUBR WVD** columns:

The two columns labeled **ADDL INSR** and **SUBR WVD** are provided to indicate by a check mark or an “X” whether this line of insurance coverage is endorsed with both the Additional Insured (which is not required by SAWS) and the Waiver of Subrogation. With this line of coverage “N/A” is already placed in the Additional Insured column on the form.

The use of the Waiver of Subrogation column **alone** does not meet SAWS Insurance Specifications.

**Instructions for Completing the ACORD  
Certificate of Liability Insurance  
(Form – ACORD 25 [Version: 2016/03])**

SAWS requires the following specific endorsement wording for only the Waiver of Subrogation endorsement, to be inserted into the **DESCRIPTION OF OPERATIONS** section of the Certificate:

**Waiver of Subrogation:**

*Either use:*

The Automobile Liability, Commercial General Liability and **Workers' Compensation** and Umbrella Liability policies include a blanket, automatic Waiver of Subrogation endorsement that provides this feature only when there is a written contract between the named Insured, the Certificate Holder (SAWS) and the City of San Antonio that requires such status.

*Or use:*

“The Automobile Liability, Commercial General Liability, **Workers' Compensation** and Umbrella Liability policies are endorsed with the Waiver of Subrogation in favor of the San Antonio Water System and the City of San Antonio.”

- c) Enter complete **POLICY NUMBER, POLICY EFFECTIVE DATE (MM/DD/YYYY),** and **POLICY EXPIRATION DATE (MM/DD/YYYY).**

- d) **WORKERS' COMPENSATION (“WC”):**

SAWS requires having an “X” entered in the box right in front of the words **WC STATUTORY LIMITS.**

- d) **EMPLOYERS' LIABILITY (“E.L.”):**

The minimum policy limits of liability shall not be less than:

|                 |                              |
|-----------------|------------------------------|
| \$ 1,000,000.00 | E.L. each Accident           |
| 1,000,000.00    | E.L. Disease - Each Employee |
| 1,000,000.00    | E.L. Disease - Policy Limit  |

- 5) **Row of blank cells** located immediately below the **WORKERS COMPENSATION AND EMPLOYERS' LIABILITY** row:

- a) This empty slot of spaces is typically used for such lines of coverage as **PROFESSIONAL (Engineer's & Architect's E&O) LIABILITY, CONTRACTOR'S POLLUTION LIABILITY, COMMERCIAL CRIME** and/or **BUILDER'S RISK** lines of insurance coverage.

- b) **ADDL INSR and SUBR WVD** columns:

**Instructions for Completing the ACORD  
Certificate of Liability Insurance  
(Form – ACORD 25 [Version: 2016/03])**

The two columns labeled **ADDL INSR** and **SUBR WVD** are provided to indicate by a check mark or an “X” whether this line of insurance coverage is endorsed with both the Additional Insured and the Waiver of Subrogation.

Since SAWS does not require the PROFESSIONAL (Engineer’s & Architect’s E&O) LIABILITY, CONTRACTOR’S POLLUTION LIABILITY, COMMERCIAL CRIME and/or BUILDER’S RISK lines of insurance coverage to be endorsed with either of the Additional Insured or the Waiver of Subrogation endorsements, do not place anything in either of the **ADDL INSR** or **SUBR WVD** columns.

- c) Enter complete **POLICY NUMBER, POLICY EFFECTIVE DATE (MM/DD/YYYY),** and **POLICY EXPIRATION DATE (MM/DD/YYYY).**
- d) The minimum limits (the per occurrence/claims-reported limit as well as the policy aggregate limit) for whichever TYPE OF INSURANCE coverage you are declaring in this OTHER space must match with or exceed limits stated in the Insurance Specifications/Requirements contained in the respective Construction Bid, RFP or RFQ document.

**NOTE:**

- 1. If the line of insurance coverage is either for Professional Liability or Contractor’s Pollution Liability, identify in the **DESCRIPTION OF OPERATIONS** section of the Certificate the coverage form under which the respective line of coverage is written – either:
  - a. Claims-made form; **or**
  - b. Occurrence basis.
- 2. In instances where the coverage form used is Claims-made include the “Retro- Active date” according to the following:
  - a. For all contracts requiring Professional Liability and/or Contractor’s Pollution Liability coverage, the “**Retro-Active date**” shall be the Project start date or earlier and must be identified in the **DESCRIPTION OF OPERATIONS** section of the Certificate.
  - b. That date must be maintained (carried forward) as the “**Retro-Active date**” throughout the life of the Project/Contract to include the two-year warranty period (if required) following the close out of the Project/Contract.
- 3. If the Occurrence based coverage form is declared, no further information is required; and

**Instructions for Completing the ACORD  
Certificate of Liability Insurance  
(Form – ACORD 25 [Version: 2016/03])**

4. If the Contractor’s Pollution Liability insurance coverage is required, the policy shall be endorsed to provide transportation coverage beyond the boundaries of the job site—the following statement noting this endorsement shall be placed in the **DESCRIPTION OF OPERATIONS** section of the Certificate;

*“Contractor’s Pollution Liability insurance coverage is endorsed to provide transportation coverage beyond the boundaries of the job site.”*

If the Contractor’s Pollution Liability policy is **not endorsed** to provide transportation coverage beyond the boundaries of the job site then the Commercial/Business Automobile Liability policy must have the CA9948 endorsement (“**Pollution Liability – Broadened Coverage for Covered Autos – Business Auto, Motor Carrier and Truckers Coverage**” forms) - the following statement noting this endorsement shall be placed either in the blank area just below the NON\_OWNED AUTOS wording on the Certificate **or** in the **DESCRIPTION OF OPERATIONS** section of the Certificate:

*“Contractor’s Commercial/Business Automobile Liability insurance coverage is endorsed with the CA9948 endorsement to provide transportation coverage beyond the boundaries of the job site.”*

Policy must also be endorsed with MCS90 endorsement when hazardous material(s) are being transported.

**7. DESCRIPTION OF OPERATIONS/LOCATIONS/VEHICLES/EXCLUSIONS  
ADDED BY ENDORSEMENT/SPECIAL PROVISIONS**

a. **DESCRIPTION OF OPERATIONS:**

- 1) Enter in this space the SAWS’ Job, Contract and/or Project number such as 09-1111 **or** P-09-011-MR;
- 2) The Project or Contract name may be included but is not required - such as “42” Water Main replacement Maltsberger from Loop 410 to U.S. 281 at Isom Road Engineering Design Project **or** Construct 1 MG Composite Potable Water Elevated Storage Tank.

b. Where applicable or as needed, enter into this section, the **DESCRIPTIONS of LOCATIONS, VEHICLES and/or EXCLUSIONS ADDED BY ENDORSEMENT.**

c. **DESCRIPTION OF SPECIAL PROVISIONS:**

SPECIAL PROVISIONS to SAWS would include the wording for the Additional Insured and



**Instructions for Completing the ACORD  
Certificate of Liability Insurance  
(Form – ACORD 25 [Version: 2016/03])**

Waiver of Subrogation endorsements, declaring the type of policy coverage under which the Professional and Contractor’s Pollution Liability policies are written, 30-day Notice of Cancellation, and other miscellaneous information that may be required; the wording may require a second page to complete.

**Special ENDORSEMENT’s** wording required on the Certificate:

**Additional Insured:**

*Either use:*

“The Automobile Liability, Commercial General Liability and **Umbrella Liability** policies include a blanket automatic Additional Insured endorsement that provides additional insured status to the Certificate Holder (SAWS) and the City of San Antonio only when there is a written contract between the named Insured and the Certificate Holder that requires such status.”

*Or use:*

“The Automobile Liability, Commercial General Liability and **Umbrella Liability** policies are endorsed naming the San Antonio Water System and the City of San Antonio as an Additional Insured.”

**Waiver of Subrogation:**

*Either use:*

The Automobile Liability, Commercial General Liability and Workers’ Compensation and **Umbrella Liability** policies include a blanket, automatic Waiver of Subrogation endorsement that provides this feature only when there is a written contract between the named Insured, the Certificate Holder (SAWS) and the City of San Antonio that requires such status.

*Or use:*

“The Automobile Liability, Commercial General Liability, Workers’ Compensation and **Umbrella Liability** policies are endorsed with the Waiver of Subrogation in favor of the San Antonio Water System and the City of San Antonio.”

**30-day Notice of Cancellation:**

“Each of the above described policies is so endorsed requiring SAWS and the City of San Antonio to be provided thirty (30) calendar days, advance written notice of cancellation or non-renewal, and not less than ten (10) calendar days advance written notice for nonpayment of premium.”

**Instructions for Completing the ACORD  
Certificate of Liability Insurance  
(Form – ACORD 25 [Version: 2016/03])**

**8. CERTIFICATE HOLDER**

SAWS shall be shown as the Certificate Holder in the Certificate Holder section located in the bottom half of the standard ACORD Certificate forms as follows:

**San Antonio Water System  
c/o Ebix BPO  
PO Box 100085-ZD  
Ref. (SAWS Contract ID/Bid/Project #)  
Duluth, GA 30096**

**9. CANCELLATION**

Despite the wording in this section of the Certificate SAWS requires the following wording to be inserted into the **DESCRIPTION OF OPERATIONS** section of the Certificate:

**30-day Notice of Cancellation:**

“Each of the above described policies is so endorsed requiring SAWS and the City of San Antonio to be provided thirty (30) calendar days, advance written notice of cancellation or non-renewal, and not less than ten (10) calendar days advance written notice for nonpayment of premium.”

**10. AUTHORIZED REPRESENTATIVE**

The original certificate(s) or form must include at least one of the below acceptable names/signatures:

- a. Agency’s Authorized person’s (wet or stamped) signature;
- b. Agent's (wet or stamped) signature; or
- c. Agent's typed in name.



# CERTIFICATE OF LIABILITY INSURANCE

DATE (MM/DD/YYYY)

THIS CERTIFICATE IS ISSUED AS A MATTER OF INFORMATION ONLY AND CONFERS NO RIGHTS UPON THE CERTIFICATE HOLDER. THIS CERTIFICATE DOES NOT AFFIRMATIVELY OR NEGATIVELY AMEND, EXTEND OR ALTER THE COVERAGE AFFORDED BY THE POLICIES BELOW. THIS CERTIFICATE OF INSURANCE DOES NOT CONSTITUTE A CONTRACT BETWEEN THE ISSUING INSURER(S), AUTHORIZED REPRESENTATIVE OR PRODUCER, AND THE CERTIFICATE HOLDER.

**IMPORTANT:** If the certificate holder is an **ADDITIONAL INSURED**, the policy(ies) must have **ADDITIONAL INSURED** provisions or be endorsed. If **SUBROGATION IS WAIVED**, subject to the terms and conditions of the policy, certain policies may require an endorsement. A statement on this certificate does not confer rights to the certificate holder in lieu of such endorsement(s).

|          |                               |                 |                |
|----------|-------------------------------|-----------------|----------------|
| PRODUCER | CONTACT NAME:                 |                 | FAX (A/C, No): |
|          | PHONE (A/C, No, Ext):         | E-MAIL ADDRESS: |                |
| INSURED  | INSURER(S) AFFORDING COVERAGE |                 | NAIC #         |
|          | INSURER A :                   |                 |                |
|          | INSURER B :                   |                 |                |
|          | INSURER C :                   |                 |                |
|          | INSURER D :                   |                 |                |
|          | INSURER E :                   |                 |                |

**COVERAGES**

CERTIFICATE NUMBER:

REVISION NUMBER:

THIS IS TO CERTIFY THAT THE POLICIES OF INSURANCE LISTED BELOW HAVE BEEN ISSUED TO THE INSURED NAMED ABOVE FOR THE POLICY PERIOD INDICATED. NOTWITHSTANDING ANY REQUIREMENT, TERM OR CONDITION OF ANY CONTRACT OR OTHER DOCUMENT WITH RESPECT TO WHICH THIS CERTIFICATE MAY BE ISSUED OR MAY PERTAIN, THE INSURANCE AFFORDED BY THE POLICIES DESCRIBED HEREIN IS SUBJECT TO ALL THE TERMS, EXCLUSIONS AND CONDITIONS OF SUCH POLICIES. LIMITS SHOWN MAY HAVE BEEN REDUCED BY PAID CLAIMS.

| INSR LTR | TYPE OF INSURANCE   | ADDL INSD | SUBR WVD | POLICY NUMBER | POLICY EFF (MM/DD/YYYY) | POLICY EXP (MM/DD/YYYY) | LIMITS                                    |       |
|----------|---|-----------|----------|---------------|-------------------------|-------------------------|---|-------|
|          | <b>COMMERCIAL GENERAL LIABILITY</b><br><input type="checkbox"/> CLAIMS-MADE   <input type="checkbox"/> OCCUR<br><br>GEN'L AGGREGATE LIMIT APPLIES PER:<br><input type="checkbox"/> POLICY <input type="checkbox"/> PRO-JECT <input type="checkbox"/> LOC<br><input type="checkbox"/> OTHER: |           |          |               |                         |                         | EACH OCCURRENCE                           | \$    |
|          |   |           |          |               |                         |                         | DAMAGE TO RENTED PREMISES (Ea occurrence) | \$    |
|          |   |           |          |               |                         |                         | MED EXP (Any one person)                  | \$    |
|          |   |           |          |               |                         |                         | PERSONAL & ADV INJURY                     | \$    |
|          |   |           |          |               |                         |                         | GENERAL AGGREGATE                         | \$    |
|          |   |           |          |               |                         |                         | PRODUCTS - COMP/OP AGG                    | \$    |
|          |   |           |          |               |                         |                         |   | \$    |
|          | <b>AUTOMOBILE LIABILITY</b><br><input type="checkbox"/> ANY AUTO<br><input type="checkbox"/> OWNED AUTOS ONLY<br><input type="checkbox"/> HIRED AUTOS ONLY<br><input checked="" type="checkbox"/> SCHEDULED AUTOS NON-OWNED AUTOS ONLY  |           |          |               |                         |                         | COMBINED SINGLE LIMIT (Ea accident)       | \$    |
|          |   |           |          |               |                         |                         | BODILY INJURY (Per person)                | \$    |
|          |   |           |          |               |                         |                         | BODILY INJURY (Per accident)              | \$    |
|          |   |           |          |               |                         |                         |   |       |
|          | <b>UMBRELLA LIAB</b>   <input type="checkbox"/> OCCUR<br><b>EXCESS LIAB</b>   <input checked="" type="checkbox"/> CLAIMS-MADE<br>DED   RETENTION \$   |           |          |               |                         |                         | EACH OCCURRENCE                           | \$    |
|          |   |           |          |               |                         |                         |   | \$    |
|          | <b>WORKERS COMPENSATION AND EMPLOYERS' LIABILITY</b><br>ANY PROPRIETOR/PARTNER/EXECUTIVE OFFICER/MEMBER EXCLUDED? (Mandatory in NH)<br>If yes, describe under DESCRIPTION OF OPERATIONS below   | Y/N       | N/A      |               |                         |                         | PER STATUTE                               | OTHER |
|          |   |           |          |               |                         |                         | E.L. EACH ACCIDENT                        | \$    |
|          |   |           |          |               |                         |                         | E.L. DISEASE - EA EMPLOYEE                | \$    |
|          |   |           |          |               |                         |                         | E.L. DISEASE - POLICY LIMIT               | \$    |

DESCRIPTION OF OPERATIONS / LOCATIONS / VEHICLES (ACORD 101, Additional Remarks Schedule, may be attached if more space is required)

**CERTIFICATE HOLDER****CANCELLATION**

SHOULD ANY OF THE ABOVE DESCRIBED POLICIES BE CANCELLED BEFORE THE EXPIRATION DATE THEREOF, NOTICE WILL BE DELIVERED IN ACCORDANCE WITH THE POLICY PROVISIONS.

AUTHORIZED REPRESENTATIVE

© 1988-2015 ACORD CORPORATION. All rights reserved.

ACORD 25 (2016/03)

Master Set Rev. 08/17/2018 The ACORD name and logo are registered marks of ACORD

ACORDs provided by Forms Boss. www.FormsBoss.com; (c) Impressive Publishing  
800-208-1977 Master Set Rev. 01/08/2018

## Supplemental Conditions

### Instructions to Bidders IB-1

IB-1 Instructions to Bidders IB-1, Page IB-7, Item 24 shall be replaced with:

24. To assist the San Antonio Water System Contracting Office in performing the bidder evaluation and subsequent recommendation of award, all bidders will submit the following items with their bids on the day of the bid opening. Failure to provide the required information may result in determining a nonresponsive bidder:
- (a) An information packet on company showing experience, organization and equipment.
  - (b) A statement regarding ability to complete the project within the schedule taking into account existing commitments.
  - (c) A completed and signed W-9 Request for Taxpayer Identification Number and Certification form.
  - (d) Record of performance on three (3) similar projects completed within the last 5 years including name of project, amount of project, project duration, name, address, and telephone number of contact person for each project.
  - (e) A baseline schedule in Microsoft Project Format, outlining completion of the project within SAWS schedule requirements. Baseline schedule should be prepared using a notice to proceed (NTP) date of October 4, 2019. Refer to Special Conditions part SC 2.4 for additional schedule requirements.

The remainder will remain unchanged.

---

---

### ARTICLE IV- CONTRACT ADMINISTRATION

Section 4.4 of the general conditions shall be amended to add the following:

**CONTRACTORS** – The Contractor shall perform the Work with its own organization on at least 40% of the total original contract price.

The term to “perform the Work with its own organization” is defined herein as utilizing only:

- Workers employed and paid directly by the Contractor or a wholly owned subsidiary of the contractor.
- Equipment owned by the contractor or its wholly owned subsidiary.
- Rented or leased equipment operated by the Contractor’s, or its wholly owned subsidiaries, employees.
- For purposes of determining the value of the Work self performed, the amount shall include all materials incorporated into the Work where the majority of the value of the Work involved in incorporating the material is performed by the Contractor’s own Organization, including wholly owned subsidiary; and
- Labor provided by staff leasing firms licensed under Chapter 91 of the Texas Labor code for non supervisory personnel if the contractor or wholly owned subsidiary

maintains direct control over the labor.

Remove Section 4.6.2.1 in its entirety and replace with the following:

**TERMINATION FOR CONVENIENCE** - The right to terminate this Contract for the convenience of Owner (including, but not limited to, non-appropriation of funding) expressly is retained by Owner. In the event of a termination for convenience by Owner, Owner shall, at least ten (10) calendar days in advance, deliver written notice of the termination for convenience to Contractor. Upon Contractor's receipt of such written notice, Contractor immediately shall cease the performance of the Work and shall take reasonable and appropriate action to secure and protect the Work then in place. Contractor shall then be paid by Owner, in accordance with the terms and provisions of the Contract Documents, an amount not to exceed the actual labor costs incurred, the actual cost of all materials installed and the actual cost of all materials stored at the Project site or away from the Project site, as approved in writing by Owner, but not yet paid for and which cannot be returned; and actual, reasonable and documented demobilization costs, if any, paid by Contractor and approved by Owner in connection with the Work in place which is completed as of the date of termination by Owner and that is in conformance with the Contract Documents, less all amounts previously paid for the Work. No amount ever shall be owed or paid to Contractor for lost or anticipated profits on any part of the Work not performed or for consequential damages of any kind or unabsorbed overhead, opportunity costs or other damages as a result of a termination for convenience under this section. In addition, any amount payable to the Contractor pursuant to this section shall be reduced in the amount of (1) any claim Owner may have against the Contractor under this Contract, and (2) the fair value, as determined by Owner, of property which is destroyed, lost, stolen or damaged so as to become undeliverable to Owner, excluding normal spoilage and except to the extent that Owner shall have otherwise expressly assumed the risk of loss with respect to such property hereunder.

Remove Section 4.9.2 of the general conditions and replace with the following:

The Contractor shall not, except upon procuring written consent from proper private parties, enter or occupy with men, tools, materials, or equipment, any privately owned land except for those on easements or rights of entry provided herein by SAWS. Contractor must submit a copy of the written consent from the land owner to SAWS.

The remaining sections of Article IV shall remain the same.

---

---

## **ARTICLE V – CONTRACT RESPONSIBILITIES**

Remove Section 5.7.1.1.7.8 in its entirety.

The remaining sections of Article V shall remain the same.

---

---

## **ARTICLE VI – CONTRACT CHANGES**

6.4 Delete section 6.4 in its entirety.

6.6 Delete section 6.6 in its entirety.

The remaining sections of Article VI shall remain the same.

---

---

## **ARTICLE VIII. - CONTRACT COMPLETION TIME**

Section 8.6 Liquidated Damages for Failure to Complete on Time: of the General Conditions shall be amended as follows:

Add the following to the end of the paragraph:

Liquidated Damages, for the purpose of this contract, will be assessed at \$500.00 per day.

The remaining sections of Article VIII shall remain the same.

---

---

# SCOPE OF WORK

---

---

## GENERAL

### SCOPE OF WORK

San Antonio Water System (SAWS) is soliciting bids for the purpose of retaining a Contractor to furnish all labor, materials, equipment and supervision to construct a total of approximately **4,990** linear feet including chain link fence with 3-strand barbed wire, mow strip, drainage crossings and gates at Clouse Water Recycle Center located at 3495 Valley Road, San Antonio, Texas 78221.

To include:

- SAWS Security Fencing
- 4 - 16' double gates (not including special channel gate)
- 2 - 6' personal gates
- 1 - 5' personal gate
- 1 - 12' gate
- 1 - 22' channel crossing with fencing
- 1 - 51'-6" channel crossing with 16' gate
- 1 - Grass drainage crossing with fencing

### PERMITS

The Contractor is responsible for obtaining any necessary permits, including tree permits.

### SCHEDULING AND SEQUENCING OF WORK

1. The Contractor shall schedule and sequence the work. **Work shall be completed within 60 days of Notice to Proceed.**
2. Complete necessary site preparation and grading before installing chain link fence and gates.

Prior to the Pre-Construction Meeting, the Contractor shall submit the following for approval:

1. Detailed Work Schedule.
2. Documentation indicating that the material meets or exceeds specifications.
3. Shop Drawings: Detailed information and specifications for materials, finishes, and dimensions.
4. Drawing illustrating detail of diagonal bracing at End, Corner, Angle, and Gate posts.

5. Drawing illustrating anchoring detail of post
6. Quality Control Submittals:
  - a) Manufacturers recommended installation instructions.
  - b) Evidence of Supplier and installer qualifications.

## **MATERIALS**

### **CHAIN LINK FENCE FABRIC**

#### **96" FABRIC, 1" PATTERN**

1. Hot dipped Galvanized chain link conforming to ASTM A392-89, Class 1; galvanized after weaving (GAW).
2. Height: 96 inches, unless otherwise shown.
3. Wire Gauge: No. 9.
4. Pattern: 1"-inch diamond-mesh.
5. Diamond Count: Manufacturer's standard and consistent for fabric furnished of same height.
6. Loops of Knuckled Selvages: Closed or nearly closed with space not exceeding diameter of wire.
7. Wires of Twisted Selvages
  - a. Twisted in a closed helix three full turns.
  - b. Cut at an angle to provide sharp barbs that extend minimum 1/4-inch beyond twist top and bottom.
8. Do not install chain link until concrete has cured minimum 7 days.

### **PIPE POSTS and LINE POSTS**

Steel pipe shall be galvanized and conform to ASTM F 1083-90 with strength and stiffness required by ASTM F 669-90a, Heavy Industrial Fence, except as modified herein.

1. End, Corner, Angle, and Gate posts shall have a 4 inch outside diameter and a weight of 9.11 pounds per foot, in conformance with ASTM F 900-84.
2. Line Post posts shall have a 2-3/8 inch outside diameter and a weight of 3.65 pounds per foot.
3. Installation of ground bonding is not required.



## TOP RAILS, MIDDLE RAILS, BOTTOM RAILS AND BRACE RAILS

1. Galvanized steel pipe.
2. Protective Coatings: As specified for posts.
3. Strength and Stiffness Requirements: ASTM F1043-08, Top Rail, Heavy Industrial Fence.
4. Steel Pipe:
  - a. ASTM F1083-08.
  - b. Outside Diameter: 1-5/8-inch.
  - c. Weight: 2.27 pounds per foot.

## FENCE FITTINGS

1. General: In conformance with ASTM F626-14, except as modified by this article.
2. Post and Line Caps:
  - a. Designed to accommodate passage of top rail through cap, where top rail required.
3. Rail and Brace Ends: Attach rails securely to each gate, corner, pull, and end post.
4. Rail Fittings: Provide the following:
  - a. Bottom and Top-Rail Sleeves: Pressed steel or round steel tubing not less than 7 inches long.
  - b. Rail Clamps: Line and corner boulevard clamps for connecting intermediate and bottom rails in the fence line to line posts.
5. Tension and Brace Bands: Pressed steel, 0.105 inch thick, minimum 0.75 inch wide, with 1.2-oz/sq. ft. metallic (zinc) coating.
6. Tension Bars: Steel, length not less than 2 inches shorter than full height of chain-link fabric with 1.2-oz/sq. ft. metallic (zinc) coating. Minimum cross section of 3/16-inch by 3/4-inch. Provide one bar for each gate and end post, and two for each corner and pull post unless fabric is integrally woven into post.
7. Truss Rod Assemblies: Steel, hot-dip galvanized after threading rod and turnbuckle or other means of adjustment. Minimum 5/16-inch diameter truss rod.
8. Barb Arms: 45-degree arms facing outward for supporting three strands of barbed wire.
9. Tie Wires, Clips, and Fasteners: According to ASTM F 626 and ASTM F 1916.
10. High-Security Round Wire Ties: For attaching chain-link fabric to posts, rails, and frames, complying with the following:
  - a. Metallic-Coated Steel: 0.192-inch diameter wire with galvanized coating thickness matching coating thickness of chain-link fence fabric.

- b. Pre-formed steel post ties.
  - c. Install with Easy Twist tool.
11. Finish:
- a. Metallic Coating for Pressed Steel or Cast Iron: Not less than 1.2 oz. /sq. ft. of zinc.
  - b. Aluminum: Mill finish.

#### TENSION WIRE

1. Metallic-Coated Steel Wire: 0.177-inch diameter, marcelled tension wire complying with ASTM A824 and the following:
2. Metallic Coating: Type II, zinc coated (galvanized) hot-dip process, with the following minimum coating weight:  
Class 5: Not less than 2.0 oz./sq. ft. of uncoated wire surface.

#### BARBED WIRE

1. Zinc-Coated Barbed Wire: ASTM A121-13, Chain Link Fence Grade:
  - a. Line Wire: Three (3) strands of No. 12-1/2 gauge.
2. Barbs:
  - a. Number of Points: Four.
  - b. Length: 3/8-inch minimum.
  - c. Shape: Round.
  - d. Diameter: No. 14-gauge.
  - e. Spacing: 5 inches.

#### GATES

Gates shall be lengths as required in scope constructed of 1½ inch diameter, galvanized 16 gauge steel tubing with all joints welded. Gates shall comply with ASTM F 900-84.

1. Hinges shall be galvanized having large bearing surfaces for clamping in position and shall be designed to swing either 180 degrees outward, 180 degrees inward, or 90 degrees in and out, and not twist or turn during action of the gate. Bolt hooks shall be galvanized steel or stainless steel.
2. Installation of gatekeepers and padlock keepers are not required except for hardware at cantilevered gates. Upon beneficial completion of the gate installations, SAWS will install chains and combination locks. Refer to details and drawings for hardware on cantilever gate.

3. Gate Operation: Opened and closed easily by one person.
4. Welded Steel Joints: Paint with zinc-based paint.
5. Chain Link Fabric: Attached securely to gate frame at intervals not exceeding 15 inches.
6. Only Tubular steel swing gates as indicated on the plans will be allowed. No temporary gap-type gates or panel gates will be allowed.

#### CONCRETE & CONCRETE FOOTING DETAILS

1. Concrete shall achieve a 21 day compressive strength of at least 3,000 psi.
2. Installation of a continuous concrete footing throughout the entire length of the new fence with proper formwork continuous.
3. All fence posts (corner, line etc...) are to be centered and incorporated into the concrete footing.
4. Bottom of fencing shall be flush with proposed footing, fencing shall be secured to the footing by a galvanized rod at two foot intervals or as submitted by contractor and approved by the Owner.
5. Footing shall be a continuous "mow strip" 6"W x 12"D and flush with existing ground elevation. Any significant grade change will require a step in fencing and "Mow strip" footing shall step as required with fence. Contractor to verify any drops in existing grades and step in footing with owner prior to setting formwork.
6. Concrete shall conform with the A - Classification for 3,000 PSI concrete as specified in SAWS specification for construction: 300 - "CONCRETE (NATURAL AGGREGATE).
7. Footing shall have two number four ( #4) rebar throughout the entire length, with #3 rebar at 10" o.c. as shown on attached drawings expansion joints shall be installed at forty foot intervals while dummy joints shall be placed every 10'.
8. Check size and spacing of rebar and footing width and depth. Ensure that there is a minimum of 3" between earth and rebar. Rebar should be centered in footing as shown on drawings.
9. Rebar must be properly supported/tied to maintain its position during concrete placement operations through the use of wire ties (18 gauge or greater), chairs, spacers or other approved supporting devices. Do not allow the use of rocks, wood blocks, or other unapproved material as support for reinforcement. Reinforcement support chairs shall be spaced typically every 5 to 6 feet. Wire tie ends shall be twisted away from concrete surfaces (toward the interior of the footer.)
10. Formwork must be properly braced and supported to prevent "blowouts" or unacceptable deformation of the formed surfaces. All formed surfaces shall be coated with approved form oil before placement of reinforcement so as to avoid coating the reinforcement.
11. During hot weather (temperatures above 80 degrees F) or during high winds, care

must be taken to prevent excessive moisture loss in the concrete which can lead to surface shrinkage cracking.

12. Top of concrete at continuous footing shall have a continuous crown to readily shed water before concrete sets.
13. Top of concrete at continuous footing shall be sloped to readily shed water away from base of posts before concrete sets.
14. Where mow-strip is installed through asphalt, the asphalt shall be saw cut to provide smooth edges. Any broken asphalt will require patching.
15. Mow Strip to be continuous across gate openings.

## CHANNELS

All channel crossing to be constructed per drawings. All galvanized materials.

- Post – to meet post standards for gauge
- Piping – to meet gate standards for gauge

## EXECUTION

### GENERAL

Install chain link fences and gates in accordance with ASTM F567-14a except as modified in this section, and in accordance with fence manufacturer's recommendations, as approved by OWNER. Erect fencing in straight lines between angle points.

1. Provide all necessary hardware for a complete fence and gate installation.

### EXAMINATION

1. Examine areas and conditions, with Installer present, for compliance with requirements for site clearing, earthwork, pavement work, and other conditions affecting.
2. Do not begin installation before final grading is completed, unless otherwise permitted by OWNER.
3. Proceed with installation only after unsatisfactory conditions have been corrected.

### PREPARATION

1. Stake locations of fence lines, gates, and terminal posts. Do not exceed intervals of 100 feet or line of sight between stakes. Indicate locations of utilities, lawn sprinkler system, underground structures, benchmarks, and property monuments.

## POST SETTING

1. Driven posts are not acceptable.
  - a. Post Hole Depth and Diameter :
    - i. Minimum 38 inches below finished grade.
  - b. 2 inches deeper than post embedment depth below finish grade.
  - c. Diameter SAWS standard 18”.
  - d. Verify that posts are set plumb, aligned, and at correct height and spacing, and hold in position during setting with concrete or mechanical devices.
  - e. Concrete Fill: Place concrete around posts to dimensions indicated and vibrate or tamp for consolidation. Protect aboveground portion of posts from concrete splatter. Blend with concrete mow strip.
2. Terminal Posts: Locate terminal end, corner, and gate posts per ASTM F 567 and terminal pull posts at changes in horizontal or vertical alignment of 15 degrees or more.
3. Line Posts: Space line posts uniformly at 10 feet o.c.
4. Post Bracing and Intermediate Rails: Install according to ASTM F 567, maintaining plumb position and alignment of fencing. Install braces at end and gate posts and at both sides of corner and pull posts.
  - a. Locate horizontal braces at mid-height of fabric 6 feet or higher, on fences with top rail, and at 2/3 fabric height on fences without top rail. Install so posts are plumb when diagonal rod is under proper tension.
5. Top Rail: Install according to ASTM F 567, maintaining plumb position and alignment of fencing. Run rail continuously through line post caps, bending to radius for curved runs and terminating into rail end attached to posts or post caps fabricated to receive rail at terminal posts. Provide expansion couplings as recommended by fencing manufacturer.
6. Tie Wires: Power-fastened or manually fastened ties configured to wrap a full 360 degrees around rail or post and a minimum of 1 complete diamond of fabric. Twist ends one and one-half machine twists or three full manual twists, and cut-off protruding ends to preclude untwisting by hand.
  - a. Maximum Spacing: Tie fabric to line posts at 12 inches o.c. and to braces at 24 inches o.c.
7. Chain-Link Fabric: Apply fabric to outside of enclosing framework. Pull fabric taut and tie to posts, rails, and tension wires. Anchor to framework so fabric remains under tension after pulling force is released.
  - a. Do not install fabric until concrete has cured minimum *7 calendar* days.
  - b. Install fabric with twisted and barbed selvage at top.

8. Barbed Wire
  - a. Install three strands of barbed wire on brackets, tighten, and secure at each bracket.
  - b. Brackets to be vertical facing outward.

#### WORK REQUIREMENTS

#### DRAWINGS AND SPECIFICATIONS

All work performed in connection with the contract shall be in accordance with details and drawings and with the requirements specified.

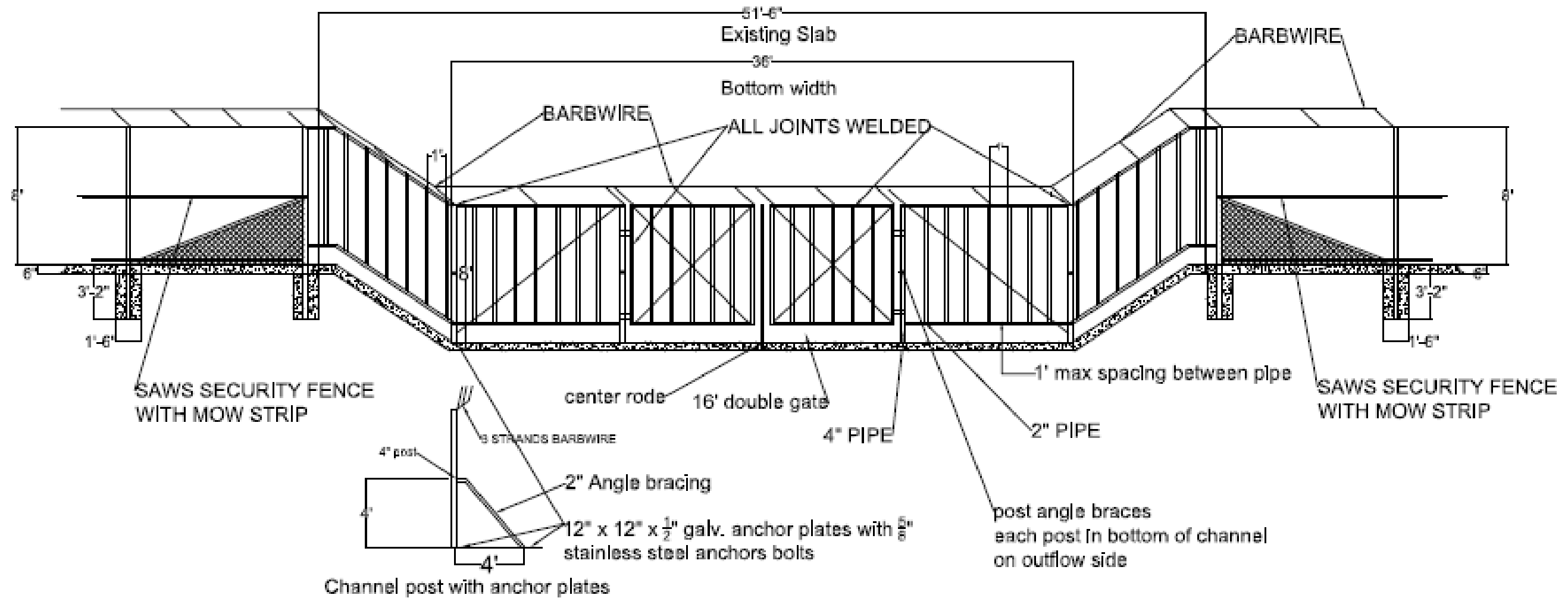

**51'-6" NORTH DRAINAGE CHANNEL CROSSING ( not to scale)**

8' High Galvanized Pipe and Gate Structure

16' Double Gate

4" Post, 12" x 12" x  $\frac{1}{2}$ " galv. anchor plates with  $\frac{5}{8}$ " stainless steel anchor bolts and 2" angle bracing on outflow side of post

2" Welded Pipe

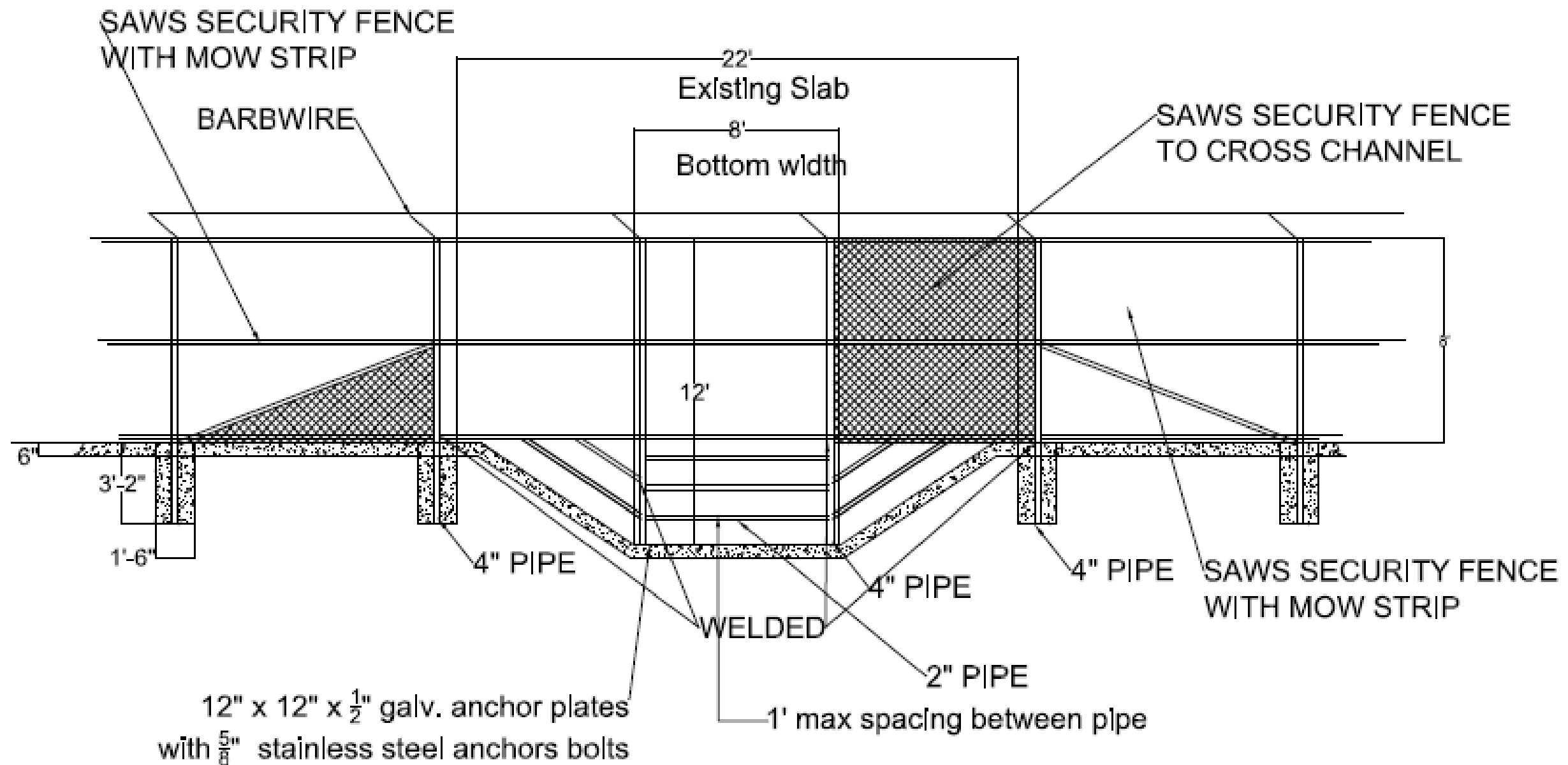

### 22' SOUTH DRAINAGE CHANNEL CROSSING ( not to scale)

12' High Galvanized Pipe and Gate Structure

4" Post, 12" x 12" x  $\frac{1}{2}$ " galv. anchor plates with  $\frac{5}{8}$ " stainless steel anchor bolts

2" Welded Pipe



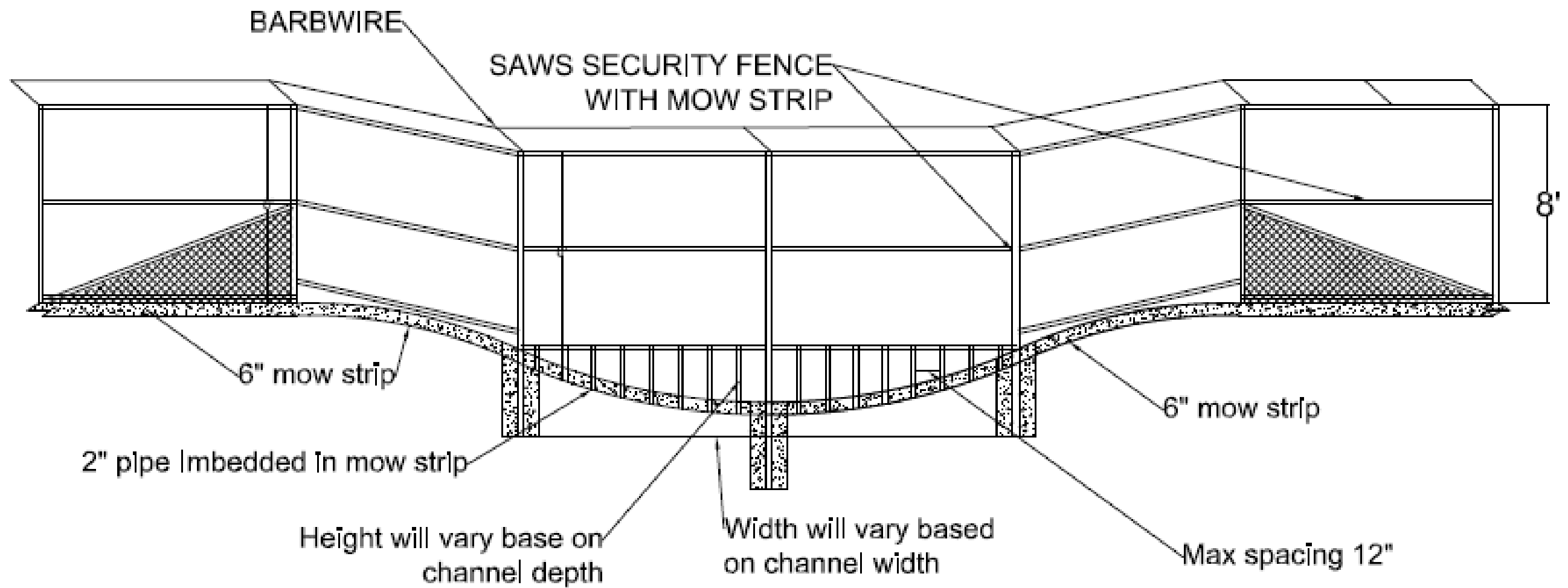

TYPICAL GRASS DRAINAGE CROSSING FENCE (not to scale)

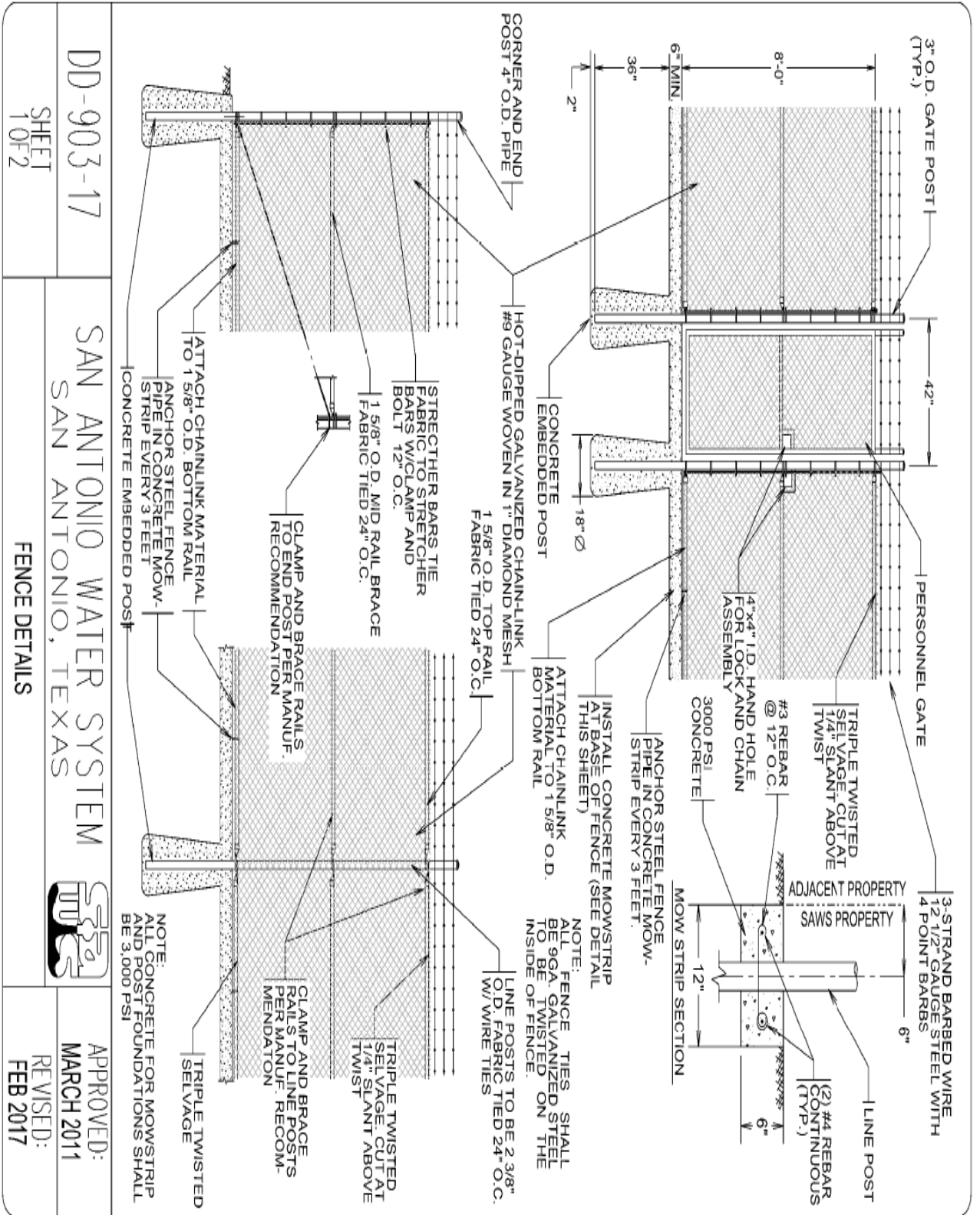

DD-903-17  
SHEET  
1 OF 2

SAN ANTONIO WATER SYSTEM  
SAN ANTONIO, TEXAS



APPROVED:  
MARCH 2011  
REVISED:  
FEB 2017

FENCE DETAILS

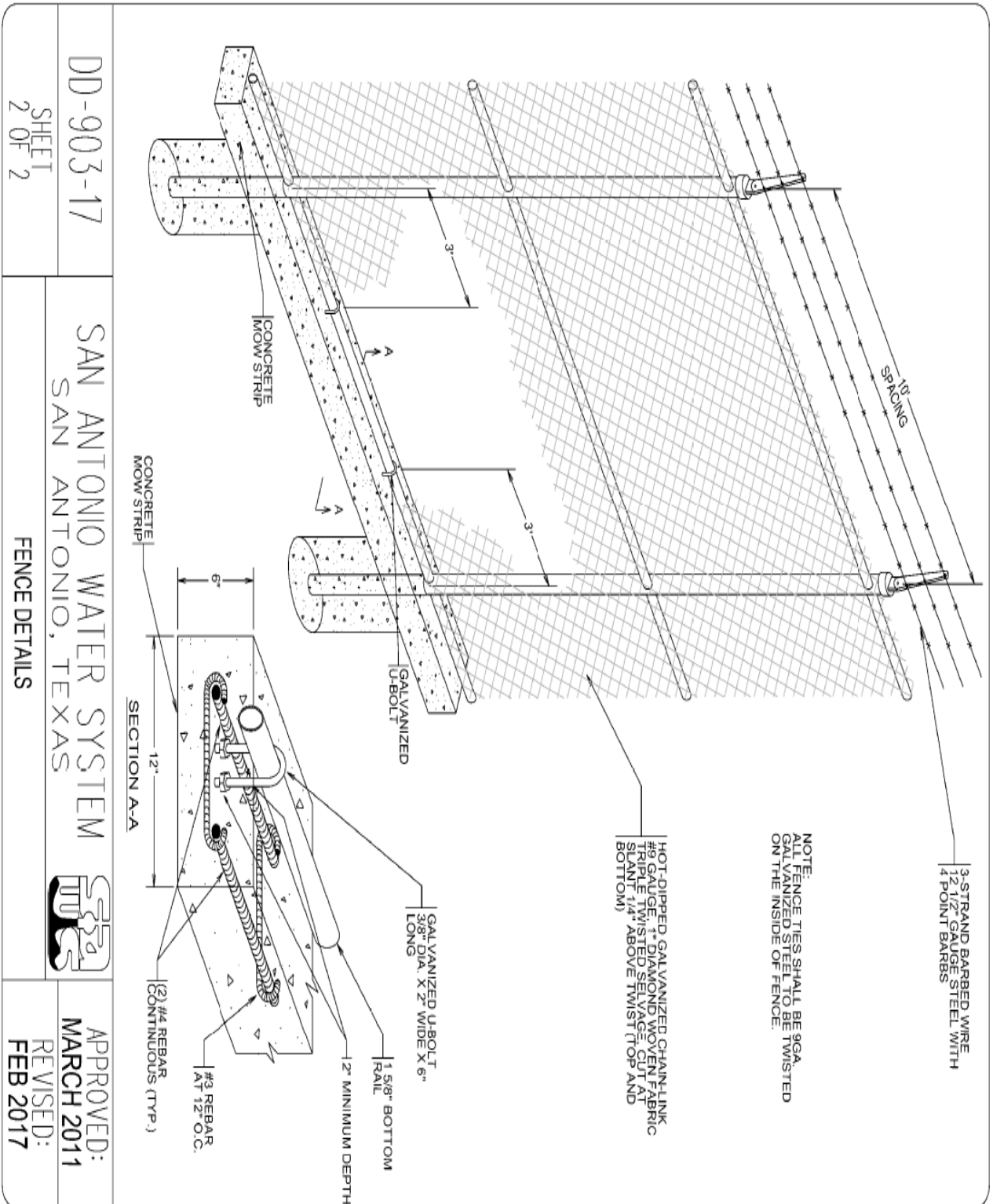

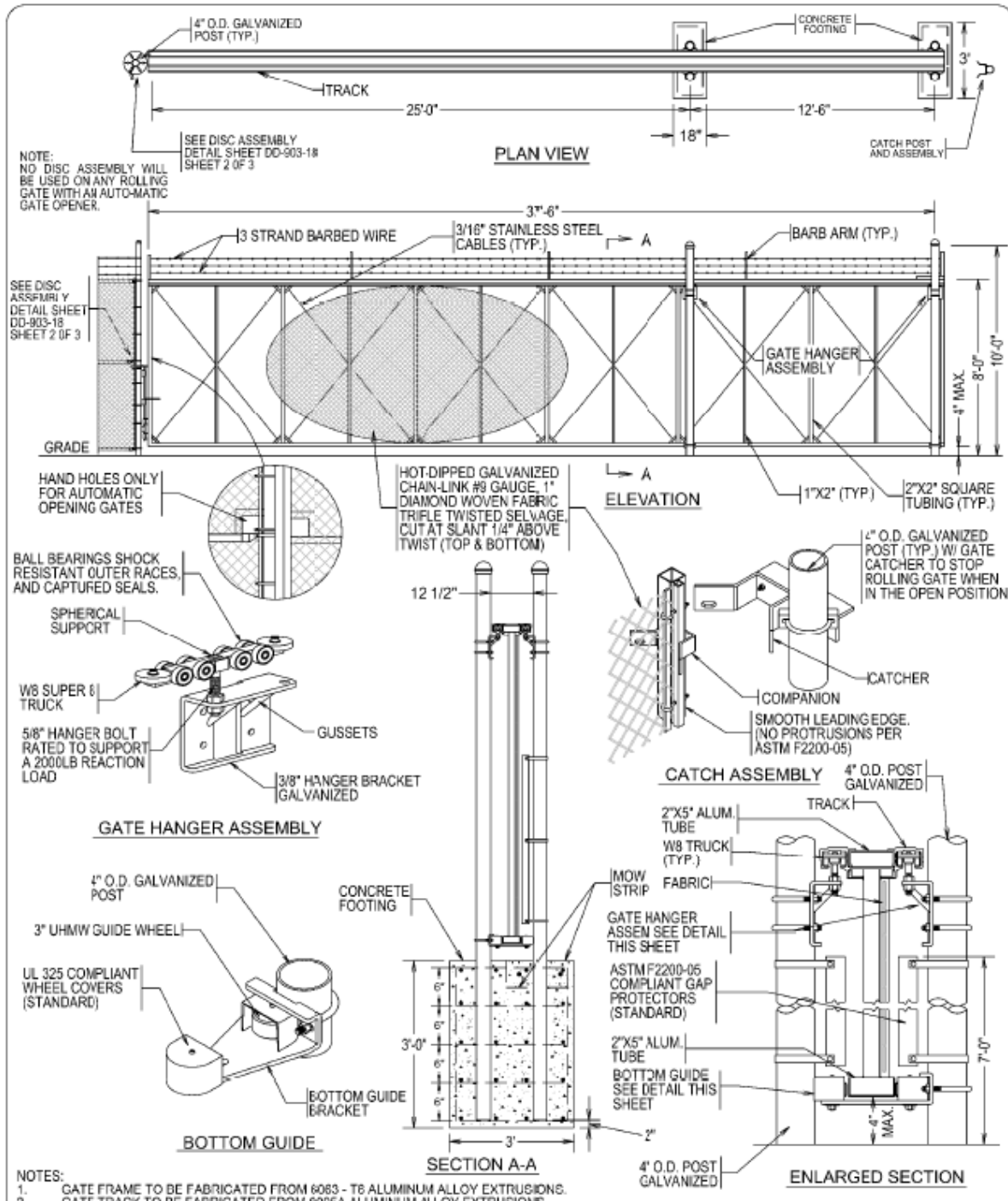

|                 |  |  |                         |
|-----------------|--|--|-------------------------|
| DD-903-18       | SAN ANTONIO WATER SYSTEM<br>SAN ANTONIO, TEXAS |  | APPROVED:<br>MARCH 2011 |
| SHEET<br>1 OF 3 | HEAVY DUTY CANTILEVER SLIDE GATE               |  | REVISED:<br>NOV 2018    |

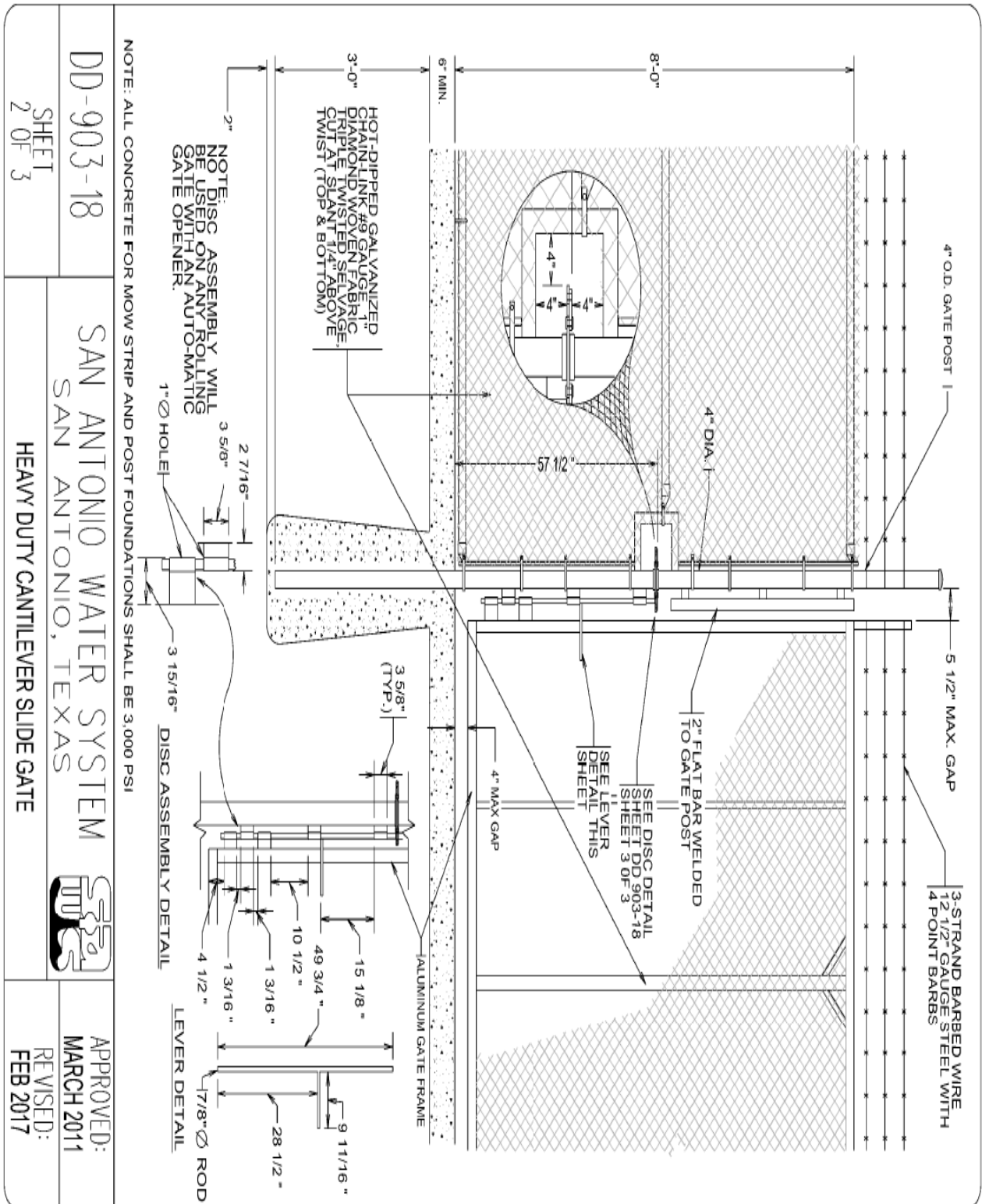

DD-903-18

SHEET  
2 OF 3

SAN ANTONIO WATER SYSTEM  
SAN ANTONIO, TEXAS



HEAVY DUTY CANTILEVER SLIDE GATE

APPROVED:  
MARCH 2011

REVISED:  
FEB 2017

NOTE:  
NO DISC ASSEMBLY WILL  
BE USED ON ANY ROLLING  
GATE WITH AN AUTO-MATIC  
GATE OPENER.

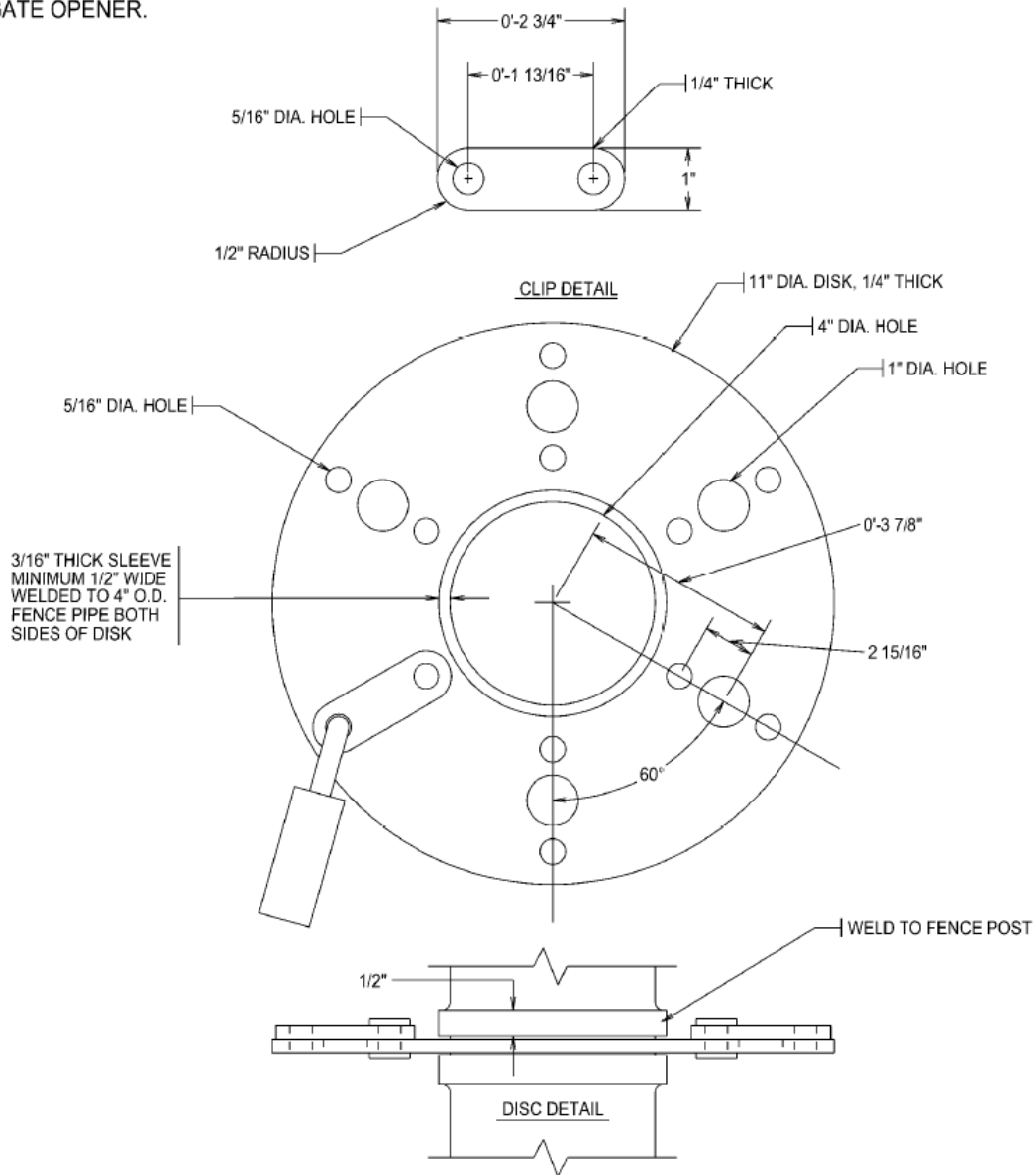

NOTE:  
1. ALL SPARE CLIPS TO BE COMPLETELY WELDED ALL AROUND. TACK WELD WILL NOT BE ACCEPTED.

|                 |  |                         |
|-----------------|--|-------------------------|
| DD-903-18       | SAN ANTONIO WATER SYSTEM<br>SAN ANTONIO, TEXAS | APPROVED:<br>MARCH 2011 |
| SHEET<br>3 OF 3 | HEAVY DUTY CANTILEVER SLIDE GATE - DISC DETAIL | REVISED:<br>FEB 2017    |

